



INSTITUT NATIONAL DE RECHERCHE EN INFORMATIQUE ET EN AUTOMATIQUE

Project-Team NeCS

Networked Controlled Systems

Grenoble - Rhône-Alpes

Theme : Modeling, Optimization, and Control of Dynamic Systems

Activity
R *eport*

2010

Table of contents

1. Team	1
2. Overall Objectives	1
2.1. Introduction	1
2.2. Highlights	2
3. Scientific Foundations	3
3.1. Multi-disciplinary nature of the project	3
3.1.1. (a) Control in Communication	3
3.1.2. (b) Communication in Control	3
3.1.3. (c) Computation in Control	5
3.1.4. (d) Control in Computation	5
3.1.5. (c + d) Integrated control/scheduling co-design	5
3.2. Main Research Directions	6
4. Application Domains	6
4.1.1. Vehicular transportation systems	7
4.1.1.1. Car industry	7
4.1.1.2. Intelligent transportation systems	7
4.1.2. Underwater systems	8
4.1.3. Systems on chip	8
4.1.4. Computer systems	8
5. Software	8
5.1. ORCCAD	8
5.2. Connectsim	9
6. New Results	9
6.1. Communication and control co-design for networked systems	9
6.1.1. Energy-aware communication and control co-design in wireless networked control systems	9
6.1.2. Control through communication channels with limited data-rate	10
6.1.3. An image coding algorithm for feedback tele-operation	10
6.1.4. Wireless transmission for estimation and control	10
6.1.5. Underwater acoustic communication	11
6.1.6. Control, communication, computation (3C) co-design	13
6.2. Collaborative distributed estimation and control	13
6.2.1. Networking protocols for estimation and control	13
6.2.2. Quadratic indices for performance evaluation of consensus algorithms	14
6.2.3. Distributed Consensus algorithms	16
6.2.4. Distributed averaging over digital noisy networks	17
6.2.5. Formation control for a fleet of underwater vehicles	18
6.3. Stability and control design of asynchronous interconnected systems	19
6.3.1. Stability of sampled-data systems	19
6.3.2. Stabilization via Communication Networks: A Time-Delay Approach	20
6.3.3. Event-based control design	20
6.3.4. Control with adaptive variable sampling	20
6.3.5. Robust control of underwater vehicles	21
6.3.6. Control architecture and tools	22
6.4. Energy-aware control of systems on chip	23
6.4.1. Energy-aware computing power control	23
6.4.2. Video decoding QoS control	24
6.5. Highway traffic model-based density estimation	24
6.6. Modeling and control of web servers	26

6.7. Observers design for multi-sensor systems: application to HDI engines	26
7. Contracts and Grants with Industry	27
7.1. Grants and contracts with Industry	27
7.1.1. IFP	27
7.1.2. AIRBUS	27
7.2. Technology transfer: start-up Karrus	27
8. Other Grants and Activities	27
8.1. Regional Initiatives	27
8.1.1. Pôle de compétitivité Minalogic/ARAVIS.	27
8.1.2. Pôle de compétitivité Minalogic/SmartEnergy.	28
8.2. National Initiatives	28
8.2.1. ANR PsiRob CONNECT	28
8.2.2. ANR VOLHAND	28
8.3. European Initiatives	28
8.3.1. FeedNetBack	28
8.3.2. Hycon2	29
8.4. National and international scientific collaborations	30
8.4.1. Collaborations inside Inria	30
8.4.2. Cooperations with other laboratories	30
9. Dissemination	30
9.1. Animation of the scientific community	30
9.2. Teaching	31
9.2.1. Courses	31
9.2.2. Advising	32
10. Bibliography	33

*NeCS is a joint project-team with GIPSA-lab (CNRS, INPG and UJF).
The team's webpage is: <http://necs.inrialpes.fr>*

1. Team

Research Scientists

Carlos Canudas de Wit [Team Leader, DR CNRS, HdR]
Federica Garin [CR INRIA- from Oct. 2010]
Nicolas Marchand [Part-time member, CR CNRS]
Alexandre Seuret [CR CNRS]
Daniel Simon [CR INRIA, HdR]

Faculty Members

Alain Kibangou [Associate Professor, UJF-CNRS Chair]
Olivier Sename [Part-time member, Professor Grenoble INP, HdR]

Technical Staff

Anne-Marie Alt [ARAVIS project engineer - until July 2010]
Florine Boudin [Young Engineer - until Nov. 2010]
Jonathan Dumon [Research Engineer]

PhD Students

Carolina Albea-Sanchez [MENRT - 2007/2010, in coll with Univ. Sevilla]
Patrick Jocelyn Andrianiana [CIFRE-Airbus - 2010-2012]
Lara Briñón Arranz [FeedNetBack project - 2008/2011]
Nicolas Cardoso de Castro [FeedNetBack project - 2009/2012]
Riccardo Ceccarelli [CIFRE-IFP-GIPSA-lab- 2007-2010]
Valentina Ciarla [Volhand project - 2010/2013]
Sylvain Durand [ARAVIS project - 2007/2010]
Luc Malrait [MENRT - 2007/2010]
Émilie Roche [FeedNetBack project - 2008/2011]
Gabriel Rodrigues de Campos [MENRT - 2009/2012]

Post-Doctoral Fellows

Alireza Farhadi [Aravis project - from Jan. 2010]
Federica Garin [Aravis project - from March to Oct. 2010]
Wenjuan Jiang [LSI Carnot Institute - until Aug. 2010]
Constantin Morarescu [Connect project - until Sept. 2010]

Administrative Assistant

Élodie Toihein [Assistant]

2. Overall Objectives

2.1. Introduction

The NeCS project-team goal is to develop a new control framework for assessing problems raised by the consideration of new technological low-cost and wireless components, the increase of systems complexity, and the distributed and dynamic location of sensors (sensor networks) and actuators. In this framework, control design is performed under general resources constraints including communication, computation, and energy. In that, the team targets an innovative step forward in the feedback design for networked controlled distributed systems by the development of combined control, computing & communication co-design. The project-team is bi-located at INRIA (Montbonnot) and at the GIPSA-LAB (at the Grenoble campus).

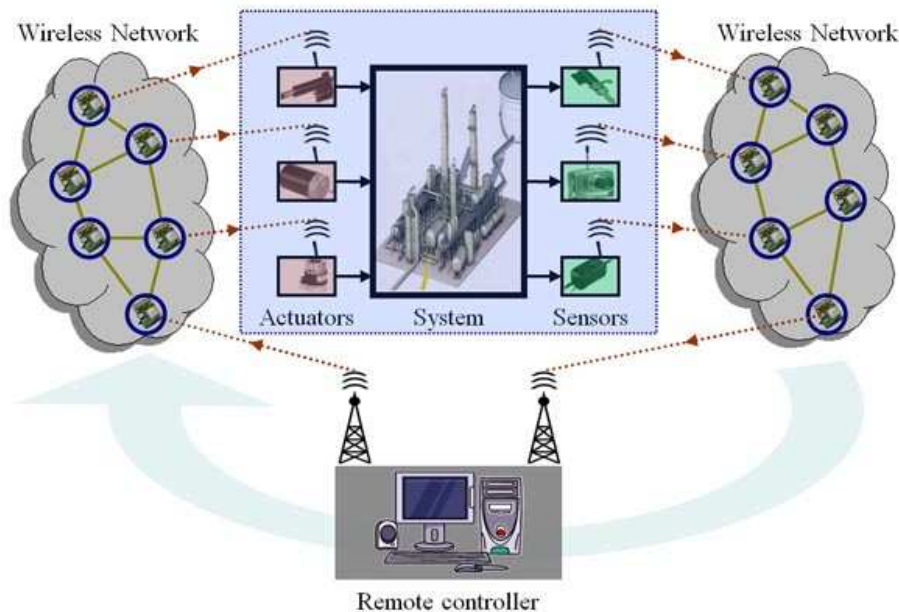

Figure 1. Overview of NeCS systems

The field of Networked Controlled Systems (NCS) refers to feedback systems controlled *over* networks, as shown in Fig 1. Such systems present new control problems posed by the consideration of several factors, such as: new technological components (i.e., wireless sensors, RF communications, adhoc networks, etc.), increase of systems complexity (i.e., increase in the number and variety of components), the distributed location of sensors and actuators, and computational constraints imposed by their embedded nature (i.e., embedded systems and systems on-chip). In this class of systems, the way that the information is transferred and processed (information constraints), and the manner in which the computation/energy resources are used (resources management), have a substantial impact in the resulting stability and performance properties of the feedback controlled systems. Inversely, the already designed feedback system can be affected by the properties of the channel transmission (latency, fading, delay jitter, lost of data, etc.), and the way that the computational and energy resources are used.

2.2. Highlights

The most relevant events and activities for the NeCS team in 2010 are the following:

- The organization of the 2nd IFAC Workshop on Distributed Estimation and Control in Networked Systems (<http://necsys2010.inrialpes.fr/>), an international workshop which was held in Annecy on Sept. 13-14th.
- The organization of the 2nd FeedNetBack Annual Workshop (<http://necsys2010.inrialpes.fr/satellite-event/>).
- The nomination of Carlos Canudas de Wit in the Board of Governors of the IEEE Control Systems Society.
- The creation in January 2010 of the start-up KARRUS-ITS (<http://www.karrus.fr/>).
- The recruitment of a new researcher in the team: Federica Garin has joined NeCS as an INRIA Junior Researcher (CR2).

- The publication of two books: [1] on co-design approaches for networked control systems and [4] on dry clutch control for automotive applications.

3. Scientific Foundations

3.1. Multi-disciplinary nature of the project

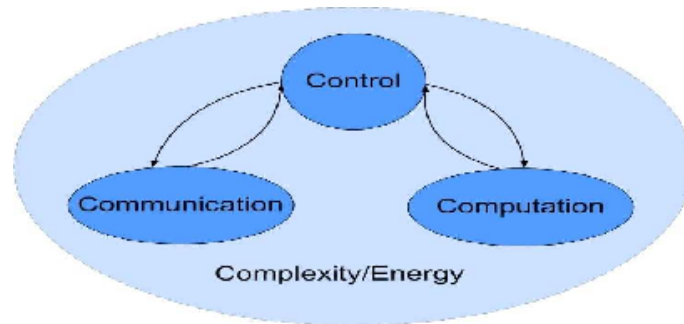

Figure 2. Relation of the NCS area with the fields of: Control, Communication, Computation.

The team's project is to investigate problems in the area of NCS with the originality of integrated aspects on computation, communication and control. The combination of these three disciplines requires the interplay of the multi-disciplinary fields of: communication, real-time computation, and systems theory (control). Figure 2, shows the natural interaction between disciplines that concern the NeCS project. The arrows describe the direction in which these areas interact, i.e.

- (a) Control in Communication
- (b) Communication in Control
- (c) Computation in Control
- (d) Control in Computation

Complexity and energy-management are additional features to be considered as well. Complexity here refers to the problems coming from: wireless networks with varying interconnection topologies, multi-agent systems coordination, scaling with respect to a growing number of sensors. Energy management concerns in particular the efficient handling of energy in wireless sensors, and means an efficient way to handle both information transmission and computation.

3.1.1. (a) Control in Communication

This topic is the study of how control-theoretic methods can be applied in order to solve some problems found in the communication field. Examples are: the Power control in cell telephones, and the optimal routing of messages in communication networks (Internet, sensor networks).

3.1.2. (b) Communication in Control

This area concerns problems where communication and information theory interact with systems theory (control). A typical scheme of a networked controlled system (NCS) is shown in Fig. 3. As an example of a classical paradigm we can mention the stabilization problem under channel (communication) constraints. A key result here [105] was to show that it was generically impossible to stabilize a linear system in any reasonable sense, if the feedback channel's *Shannon classical capacity* C was smaller than the sum of the logarithms, base 2, of the unstable eigenvalues. In other words, in order to be able to cope with the stabilization problem under communication constraints, we need that

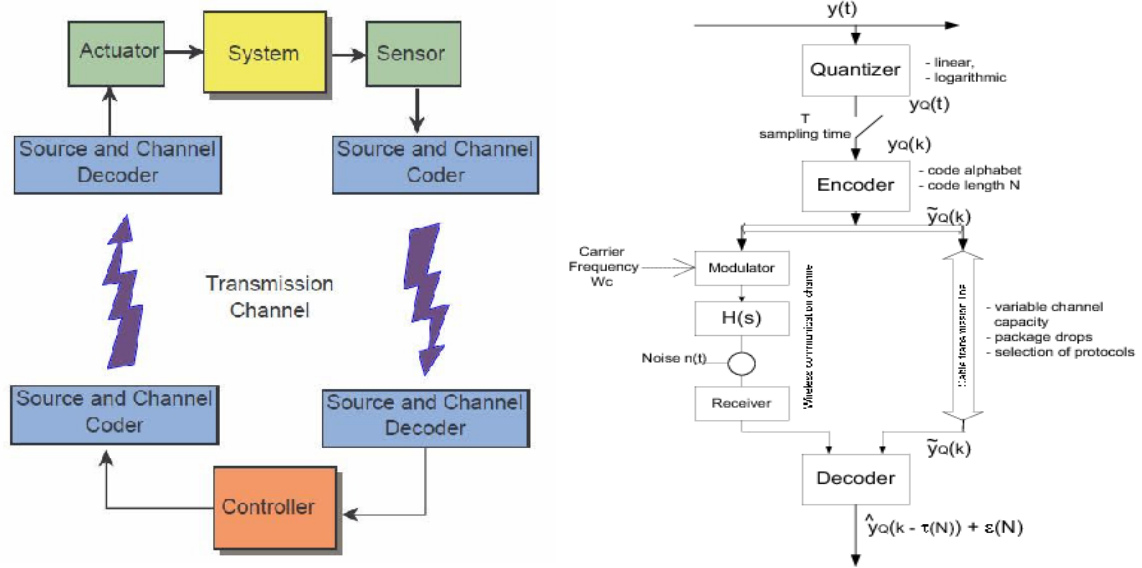

Figure 3. Block diagram of a networked controlled system. General closed loop configuration (left), details of the transmission path (right)

$$C > \sum_i \log_2 \lambda_i$$

where the λ_i 's are unstable eigenvalue of the open loop system. Intuitively, this means that the rate of information production (for discrete-time linear systems, the intrinsic rate bits/time equals $\sum_i \log_2 \lambda_i$) should be smaller than the rate of information that can be transmitted throughout the channel. In that way, a potentially growing signal can be cached out, if the information of the signal is sent via a channel with fast enough transmission rate. In relation to this, a problem of interest is the coding and control co-design. This issue is motivated by applications calling for data-compression algorithms aiming at reducing the amount of information that may be transmitted throughout the communication channel, and therefore allowing for a better resource allocation and/or for an improvement of the permissible closed loop system bandwidth (data-rate).

Networked control systems also constitute a new class of control systems including specific problems concerned by delays. In NCS, the communication between two agents leads unavoidably to transmission delays. Also, transmission usually happens in discrete time, whereas most controlled processes evolve in continuous time. Moreover, communication can induce loss of information. Our objectives concern the stabilization of systems where the sensor, actuator and system are assumed to be remotely commissioned by a controller that interchanges measurements and control signals through a communication network. Additional dynamics are introduced due to time-varying communication delays, asynchronous samplings, packets losses or lack of synchronization. All those phenomena can be modelled as the introduction of time-delays in the closed loop system. Even if these time-delay approaches can be easily proposed, they require careful attention and more complex analysis. In general, the introduction of delays in a controlled loop leads to a reduction of the performance with respect to the delay-free situation and could even make the systems unstable. Our objective is to provide specific modelling of these phenomena and to develop dedicated tools and methodologies to cope with stability and stabilization of such systems.

3.1.3. (c) Computation in Control

This area concerns the problem of redesigning the control law such as to account for variations due to the resource allocation constraints. Computation tasks having different levels of priority may be handled by asynchronous time executions. Hence controllers need to be re-designed as to account for non-uniform sampling times resulting in this framework. Questions on how to redesign the control laws while preserving its stability properties are in order. This category of problems can arise in embedded systems with low computation capacity or low level resolution.

3.1.4. (d) Control in Computation

The use of control methods to solve or to optimize the use of computational resources is the key problem in this area. This problem is also known as a scheduling control. The resource allocations are decided by the controller that try to regulate the total computation load to a prefixed value. Here, the “system” to be regulated is the process that generates and uses the resources, and not any physical system. Hence, internal states are computational tasks, the control signal is the resource allocation, and the output is the period allowed to each task.

3.1.5. (c + d) Integrated control/scheduling co-design

Control and Computation co-design describes the possibility to study the interaction or coupling between the flows (c) and (d). It is possible, as shown in Figure 4, to re-frame both problems as a single one, or to interpret such an interconnection as the cascade connection between a computational system, and a physical system.

In our framework the feedback scheduling is designed w.r.t. a QoC (Quality of Control) measure. The QoC criterion captures the control performance requirements, and the problem can be stated as QoC optimization under constraint of available computing resources. However, preliminary studies suggest that a direct synthesis of the scheduling regulator as an optimal control problem leads, when it is tractable, to a solution too costly to be implemented in real-time [67]. Practical solutions will be found in the currently available control theory and tools or in enhancements and adaptation of current control theory. We propose in Figure 4 a hierarchical control structure: besides the usual process control loops we add an outer control loop which goal is to manage the execution of the real-time application through the control of the scheduling parameters of the inner loops. Together with the outer loop (working on a periodic sampled time scale) we also need a scheduling manager working on a discrete events time scale to process exception handling and admission control.

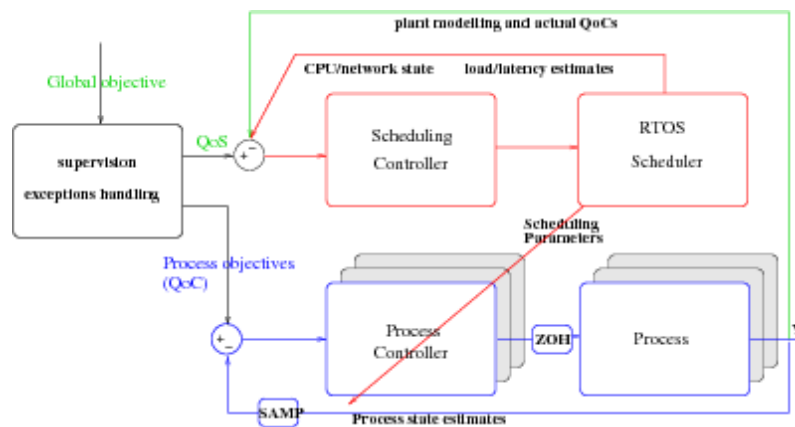

Figure 4. Hierarchical control structure.

The task periods directly affect the computing load, they have been chosen as actuators. They can be implemented through software variable clocks. As timing uncertainties cannot be avoided and are difficult to model or measure, we currently design robust control algorithms using the H_∞ control theory, which have been successfully simulated and experimentally validated [102].

This methodology is supported by the software ORCCAD (see Section 5.1) where a run-time library for multi-rate multitasking has been developed and integrated. It will be further improved using a QoS-based management of the timing constraints to fully benefit from the intrinsic robustness of closed loop controllers w.r.t. timing uncertainties.

3.2. Main Research Directions

The main objective of the project is to develop a unified control, communication, computing co-design methodology explicitly accounting for all the components involved in the system controlled over a network. This includes quantifier properties, scheduling parameters, encoder/decoder, alphabet length, bandwidth of the transmission media (wire or wireless), delays, resource allocation, jitter, etc.

These components, including the control laws, should be designed so as to optimize performance/stability trade-offs resulting from the ceiling of the computing resources, the channel capacity limitations and the quality of the send/received information protocols.

In short the project is centered along the following 3 main axes:

1. **Control under Communications Constraints.** One well established topic along this axis concerns the coding and control co-design. That is, the design of new code alphabets simultaneously than the design of the control law. Or equivalently, the ability of designing codes containing information pertained to the system model and the control law. The objective being the improvements of the overall closed loop performances. Besides this matter, additional improvements pertain to the field of the information theory are also in order.
2. **Control under Computational resources constraints.** The main objective here is the design of control loops by explicitly accounting for the network and/or the computing resources. Dynamic allocation of such resources depends on the desired controlled systems specifications. Keys aspects to be considered are: the design of controllers with variable sampling time, the robustness with respect to time uncertainties such as the input/output latencies, the global control of resources and its impact over the performance and the robustness of the system to be controlled. We aim to provide an *integrated control and scheduling co-design* approach [103].
3. **Controlling Complexity** Design and control of partially cooperative networked (possible also multi-agent) systems subject to communication and computational constraints. Here, a large number of entities (agents), having each its own goal share limited common resources. In this context, if there is no minimum coordination, dramatic consequences may follow, on the other hand, total coordination would be impossible because of the lack of exhaustive, reliable and synchronous information. Finally, a local "network of strategies" that are based on worst-case assumptions is clearly far from being realistic for a well designed system. The aim of this topic is to properly define key concepts and the relevant variables associated to the above problem (sub-system, partial objective, constraints on the exchanged data and computational resources, level of locally shared knowledge, key parameters for the central level, etc).

4. Application Domains

4.1. Application domains

Closing feedback loops around Wireless sensor networks offers new challenges and new opportunities for the area of control. Several new application areas can be enabled, or enhanced if systematic methods are developed for the design of NCS. Examples include:

- Intelligent buildings, where sensor information on CO_2 concentration, temperature, room occupancy, etc. can be used to control the heating, ventilation and air conditioning (HVAC) system under multi-objective considerations of comfort, air quality, and energy consumption.
- Intelligent transportation systems, where traffic flow or density can be measured using novel wireless technologies and used to determine control inputs such as on-ramp metering schemes and variable message signs.
- Disaster relief operations, where data collected by sensor networks can be used to guide the actions of rescue crews and operate automated rescue equipment.
- Surveillance using swarms of Uninhabited Aerial Vehicles (UAVs), where sensor information (from sensors on the ground and/or on-board the vehicles) can be used to guide the UAVs to accomplish their mission.
- Environmental monitoring and exploration using schools of Autonomous Underwater Vehicles (AUVs), where underwater sensors and communication are used to guide the AUVs.
- Infrastructure security and protection using smart camera networks, where the images collected are shared among the cameras and used to control the cameras themselves (pan-tilt-zoom) and ensure tracking of potential threat.

In particular, the team is already involved in the areas described in detail below.

4.1.1. Vehicular transportation systems

4.1.1.1. Car industry

Car industry has been already identified as a potential homeland application for NCS [79], as the evolution of micro-electronics paved the way for introducing distributed control in vehicles. In addition, automotive control systems are becoming the more complex and iterative, as more on-board sensors and actuators are made available through technology innovations. The increasing number of subsystems, coupled with overwhelming information made available through on-board and off-board sensors and communication systems, rises new and interesting challenges to achieve optimal performance while maintaining the safety and the robustness of the total system. Causes of such an increase of complexity/difficulties are diverse: interaction between several control sub-systems (ABS, TCS, ESP, etc.), loose of synchrony between sub-systems, limitations in the computation capabilities of each dedicate processor, etc. The team had several past collaborations with the car industry (Renault since 1992, and Ford), and has recently initiate a new collaboration on observer design and fault diagnostics design for multi-sensor systems in Homogeneous Charge Diesel engines, in collaboration with the IFP. In addition, a new ANR project, named VOLHAND, has been started in collaboration with INRETS, JTEKT, Fondation Hopale, LAMIH, CHRU. It aims at developing a new generation of electrical power-assisted steering specifically designed for disabled and aged persons.

4.1.1.2. Intelligent transportation systems

Throughout the world, roadways are notorious for their congestion, from dense urban network to large freeway systems. This situation tends to get worse over time due to the continuous increase of transportation demand whereas public investments are decreasing and space is lacking to build new infrastructures. The most obvious impact of traffic congestion for citizens is the increase of travel times and fuel consumption. Another critical effect is that infrastructures are not operated at their capacity during congestion, implying that fewer vehicles are served than the amount they were designed for. Using macroscopic fluid-like models, the NeCS team has initiated new researches to develop innovative traffic management policies able to improve the infrastructure operations. This activity is currently focused on automatic model calibration and traffic prediction, two important items to implement efficient Intelligent Transportation Systems (ITS) such as traffic responsive ramp metering and varying speed limit as well as producing relevant user information. The team is currently setting up a consortium with local authorities involved in traffic management to build to a demonstrator called GTL (Grenoble Traffic Lab). One target of this activity is to transfer part of the developed technology to a start-up currently incubated at GRAIN (Grenoble incubator for high tech start-ups) named Karrus.

4.1.2. Underwater systems

Underwater systems, as presently used or intended by the offshore industry and marine research, are subject to severe technological constraints. In AUVs, the on-board power is limited and calls for both control and computing optimization. The links between the master and slave nodes use ultrasonic devices, which have a very low bandwidth and are subject to frequent transient loss, thus calling for sharing the decisional process among the nodes and for a robust implementation of the distributed control, taking into account the communication network features. These constraints together with the potential cost of failures make these systems good candidates for safe and flexible control, communication and computing co-design. The team already got a significant experience in this domain with a past collaboration with IFREMER and other EU projects. Currently, the projects CONNECT and FEEDNETBACK deal with this type of problems (see Sections 8.2 and 8.3).

4.1.3. Systems on chip

Achieving a good compromise between computing power and energy consumption is one of the challenge in embedded architecture of the future. This management is especially difficult for 45nm or 32nm known to be at the limit of the scalability. Automatic control loops have therefore to be designed in order to make the performance fit the requirement in order to minimize the energy loss in a context of highly unknown performance of the chip. The main objective is to control the computing power and the consumption using the voltage and frequency automatically according to the requirements of the OS. For this, appropriate sensors must be implemented on the chip and a high-performance repartition between hardware and software implementation must be made.

4.1.4. Computer systems

Server systems (Internet, database, news, etc.) is a very active industry in the communication area. Tuning servers is currently done with the experience and the feeling of human operators with potential problems like under-optimality or even trashing phenomena in case of bad tuning. The NeCS team has started research on that subject in collaboration with the INRIA-Sardes team for using control theory tools in closed loop server systems and especially for controlling their admission. This goes in the direction to fully autonomous servers in completely heterogeneous aggregation of servers.

5. Software

5.1. ORCCAD

Participants: Soraya Arias [SED], Florine Boudin, Roger Pissard-Gibollet [SED], Daniel Simon [correspondant].

ORCCAD is a software environment that allows for the design and implementation of the continuous and discrete time components of complex control systems, e.g. robotics systems which provided it first ground [61]. It also allows the specification and validation of complex missions to be performed by the system. It is mainly intended for critical real-time applications, in which automatic control aspects (servo loops) have to interact narrowly with the handling of discrete events (exception handling, mode switching). Orccad offers a complete and coherent vertical solution, ranging from the high level specification to real-time code generation.

The ORCCAD V3 software was designed with proprietary tools that moreover are now becoming obsolete. ORCCAD V4 is currently deeply re-engineered to be compliant with open-source and free software tools (Java/Eclipse). Current targets are Linux (Posix threads) and Xenomai, a real-time development framework cooperating with the Linux kernel (<http://www.xenomai.org>).

ORCCAD is supported by the *Support Expérimentations & Développement (SED)* service of INRIA-Rhône-Alpes. ORCCAD is used by the experimental robotics platforms of INRIA-Rhône-Alpes and by the Safenecs ANR project in a real-time simulator of a X4 drone [48]. New functionalities and updates are developed jointly by the *SED* service and researchers of the NECS and SARDES teams.

Web page: <http://orccad.gforge.inria.fr>.

5.2. Connectsim

Participants: J. Dumon [contact person], P. Bellemain [GIPSA-Lab], S. Nicolas [PROLEXIA], N. Maciol [PROLEXIA], F. Martinez [ROBOSOFT], J. Caquas [ROBOSOFT].

CONNECTSIM is a shared platform having as main goal the validation of the fundamental principles developed in the CONNECT project. It integrates agent's models, communication media including their limitations, heterogeneous network, and all the variants of the multi-agent control strategies. Besides the models and simulation engine, the simulator is complemented with an interactive graphical interface which is used to visualise and interpret the state of the multi-agent control system in one direction and to send high or low-level controls to the agents. The validation scenario is a real-size application complex enough to enforce the pertinence of our results. The simulator CONNECTSIM is now being used as an open research tool for various applications in the field of multi-agents networked systems, particularly within the FEEDNETBACK project.

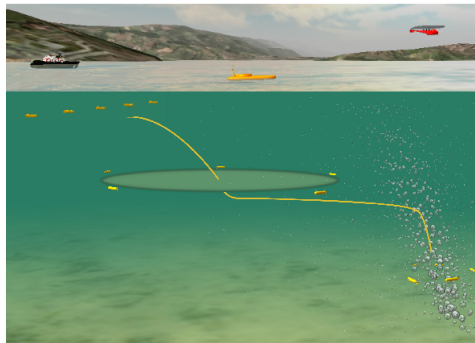

Figure 5. A scenario's view obtained with CONNECTSIM

Web page: <http://www.lag.ensieg.inpg.fr/connect/simulator.php>

6. New Results

6.1. Communication and control co-design for networked systems

6.1.1. Energy-aware communication and control co-design in wireless networked control systems

Participants: C. Canudas de Wit [Contact person], N. Cardoso de Castro, K. Johansson [KTH].

Previous work in [63], about energy-aware communication and control co-design in wireless Networked Control Systems (NCS), was focusing on energy-aware and entropy coding in NCS.

To enlarge our vision of this topic, we carried out a survey about energy-aware communication and control co-design. This work has been done by Nicolas Cardoso, Carlos Canudas de Wit and Karl-Henrik Johansson and has led to a publication at the NecSys'10 conference, [24].

Because energy is a key resource in NCS, in particular in applications concerning wireless networks, we reviewed the multi-layer architecture of those systems in the light of their energy-use, and we pointed out major contributions in the area of energy-management policies, layer per layer. This review of the literature is organized according to the layered communication architecture, covering, from bottom to top, the Physical, Data Link, Network, and Application layers. We have specifically focused on advances that concern energy-aware management in wireless communication and control co-design. It is argued that existing work is limited to single layer approaches, with a lack of design methods taking into account several layers.

This work helped us to understand how energy is consumed in wireless network nodes and to identify the most interesting topics to put our efforts on. We noticed that an important amount of energy is wasted in idle-listening, *i.e.* when a node is fully woken up, ready to transmit and to receive without any message to send or receive. Many radio chips in wireless nodes embed low-consuming radio modes to save energy. These low-consuming modes are alternative modes between fully awake (ON) and fully asleep (OFF) modes. We focus now on the control of these radio modes in order to save further energy in NCS.

6.1.2. *Control through communication channels with limited data-rate*

Participants: C. Canudas de Wit [Contact person], A. Farhadi, J. Jaglin, J. Dumon.

We have proposed a new adaptive differential coding algorithm for systems controlled via the digital noiseless channel with limited channel rate. The proposed technique reaches global stability for noiseless Multi-Input, Multi-Output (MIMO) systems. Two main advantages of the proposed algorithm are: 1) It provides robustness against disturbances; while improving transient behavior. 2) The global stability is reached; while the rate theoretical limits are achieved under constant length coding. These are achieved by introducing a Dwell-Time state in addition of Zoom-In and Zoom-Out classical modes. The Dwell-Time mechanism introduces a hysteretic effect that smoothes out the periodic and oscillatory behavior observed in other approaches such as Zoom-In, Zoom-Out quantifiers. We provided a detailed analysis of the stability conditions for MIMO systems, and some comparisons with other similar approaches. This work is the topic of the submitted paper [77]

An interesting application where the data-rate constraint is hard, is the control of oil well drilling, where information from the sensors to the controller is transmitted via an acoustic channel, with little data-rate and relevant delay. In oil well drilling operations, one of the important problem to deal with is represented by the necessity of suppressing harmful stick-slip oscillations. A control law named D-OSKIL mechanism uses the weight-on-the-bit force as a control variable to extinguish limit cycles. It uses the value of the bit angular velocity that is found through an unknown parameter observer by means of the measure of the table rotary angular speed. To improve this former estimation, we add the measurement of the angular velocity of the bit that, due to the technological constraints, arrives delayed. This new design leads us to the analysis of a time-varying delay system. This work has been presented at ACC 2010 [21].

6.1.3. *An image coding algorithm for feedback tele-operation*

Participants: C. Canudas de Wit [Contact person], W. Jiang, J. Dumon, O. Sename.

We have initiated studies on adaptive image coding in the context of tele-operation. In here we trade issues on Quality of Service (quality of image) with quality of control. In our first investigations, we have proposed a new image coding algorithm for the wireless controlled electrical vehicle (scale 1/3). The tele-operation system is based on a mathematical driver model written in the spatial equation form (model that we have also proposed), where the driver is considered as a feedback controller. An optimal quality parameter for image compression is calculated by an iterative method which takes into account the trade-off between the network time-delay and image network flow rate. Two papers have been submitted: one for the ACC 2011, and another with the driver model for the IFAC WC 2011.

6.1.4. *Wireless transmission for estimation and control*

Participant: A. Kibangou.

The studies reported in this subsection concern the data transmission over unknown non-orthogonal fading channel in scenarios involving several agents, sensors or actuators. In most of works, the nodes are organized in a network where each sensor processes its individual measurement and transmits the result over an orthogonal multiple-access channel (MAC) to the sink node. In such channels, collisions and interferences between nodes are avoided so that the main impairment of the communication channel concerns noise. Orthogonal MAC can be obtained using TDMA (Time Division Multiple Access), FDMA (Frequency Division Multiple Access) or CDMA (Code Division Multiple Access) protocols. In the first one, the time is divided into slots allocated to each node. Such a scheme induces a latency that can be crucial for feedback control. In the second one, the bandwidth is divided into sub-band allocated to each user. The bandwidth being limited, scalability is a crucial question in this case. For the third scheme, each node is assigned a signaling waveform (or code) generally assumed to be orthogonal, equi-correlated and perfectly correlated with a perfect synchronization in node transmissions [108].

In addition to noise, wireless transmissions are also subject to fading. In most works on wireless transmission for control and estimation, fading is in general ignored or assumed to be known. In a recent work, a distributed estimation scheme including a channel estimation using pilot signals was suggested [90]. The derivations were made for parallel channels in a fusion center based wireless sensor network (WSN). It is necessary to point out that the number of parallel channels is limited by the bandwidth and the number of nodes in the network.

Space-time block processing coding and modulation schemes can also be considered. For scenarios in which there is perfect channel state information (CSI), several linear precoding systems have been proposed (see [100] and references therein). However, in practice the CSI at the transmitter suffers from inaccuracies caused by errors in channel estimation and/or limited, delayed or erroneous feedback [83]. The derivation of robust coding methods with few or no knowledge on the transmission channel is then a topic of particular interest.

By considering non-orthogonal unknown fading channel, multiple transmitting node and a single sink node, we have introduced two kinds of precoding where the CSI is not required. In the first one, data are doubly spread before transmission. The precoding can be viewed as bilinear [30]. The second one is a nonlinear (polynomial) precoding scheme. The proposed nonlinear precoding scheme gives rise to a homogeneous Volterra-like input-output equation whose inputs depend on the coding sequence whereas the kernel depends on the informative symbols and on the channel parameters [29]. Both schemes give rise to multidimensional and multilinear data which can be viewed as tensors [16], [81]. The performance of the polynomial approach is depicted in Fig. 6 and 7 we plot the BER according to the signal-to-noise ratio (SNR).

In general, the proposed decoding methods give good results. Significant improvements are obtained by increasing the number N of rows for the encoding matrix. That is an expected result since by increasing the number of rows for the encoding matrix, the least squares estimation of the data tensor is improved. The improvement is particularly significant for SNR values higher than 2 dB.

6.1.5. Underwater acoustic communication

Participants: A. Kibangou [contact person], C. Siclet, L. Ros, J. Dumon.

Wireless underwater communications can be established by transmission of acoustic waves. The corresponding transmission channels are generally recognized as one of the most difficult communication media to use today. The bandwidth available for communication is extremely limited. Although the communication bandwidth is very low, underwater acoustic channels are, in fact, wideband due to the small ratio of carrier frequency to the signal bandwidth.

Sound propagates at a very low speed ($\approx 1500\text{m/s}$), and propagation occurs over multiple paths. Delay spreading over tens or even hundreds of milliseconds results in frequency selective signal distortion, while motion creates an extreme Doppler effect [104].

The OFDM (orthogonal Frequency Division Multiplexing) technique, a multi-carrier modulation scheme in which broadband data is effectively transmitted in parallel as K narrowband channels on K orthogonal subcarriers, has been claimed to be one of the most promising communication technologies for achieving high data rate and large system capacity [82]. It allows designing low complexity receivers to deal with highly dispersive channels [107]. This facts motivates the use of OFDM in underwater environments.

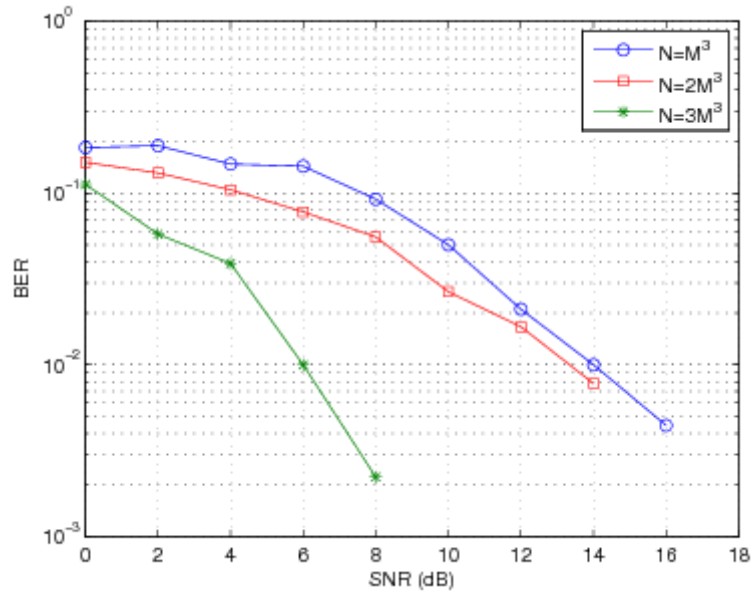

Figure 6. Performance evaluation with different number of rows for the encoding matrix (ALS-PARAFAC case).

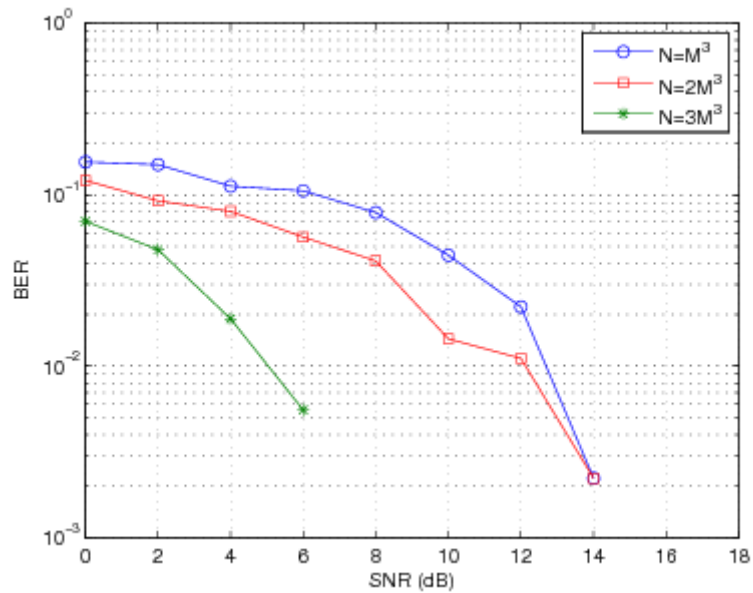

Figure 7. Performance evaluation with different number of rows for the encoding matrix (Joint diagonalization).

In order to adequately recover the transmitted information, algorithms at the receiver must include estimation and compensation of the Doppler scaling factor, channel estimation, and information symbols estimation. Several approaches have been suggested in the literature for estimating the Doppler scaling factor. They are based on the use of preamble and postamble of a packet consisting of multiple OFDM blocks [84] or by exploiting correlation induced by the cyclic prefix [82]. Then, the received signal is resampled by using a sampling period related to the estimated Doppler scaling factor. When the Doppler scaling factor is estimated using a preamble and/or a postamble of a packet, it is necessary to add the estimation and the compensation of residual carrier frequency offset (CFO) since the Doppler can vary between consecutive OFDM blocks inside a given packet.

We have derived new per-block data processing algorithms based on high resolution harmonic estimation methods for estimating both Doppler scaling factor and channel parameters (path gains and delays). Then the informative symbols are estimated using zero-forcing or MMSE (Minimum Mean Square Error) based equalization schemes. The advantage of the proposed scheme is to avoid data resampling and residual CFO estimation and compensation [32], [31], [33].

We have also designed specifications and the packet loss law to be implemented in the CONNECTSIM software.

An overview on our tools for underwater communication can be found on the FeedNetBack report [54].

6.1.6. Control, communication, computation (3C) co-design

Participants: C. Canudas de Wit [Contact person], A. Farhadi, S. Zampieri [Università di Padova], L. Schenato [Università di Padova].

One of the objectives of the NeCS team is to propose a co-design framework, which allows the integration of control, communication, computation, complexity, and energy in Networked Control Systems (NCS). As a first step to create such a co-design framework, we have to fully understand the constraints imposed by control, communication, computation, complexity, and energy on some case studies. Therefore, in [52], we studied the three case studies of the FeedNetBack European project: 1) Fleet of underwater vehicles, 2) Smart network of surveillance cameras, 3) Smart network of cameras for motion capture. Then, following this study, we identified the interactions between control, communication, computation, complexity, and energy in these case studies. Next, we formulated an integration framework for control, communication, computation (3C) co-design for fleet of underwater vehicles and smart network of surveillance cameras. Right now, we are developing the formulated 3C co-design framework for the fleet of underwater vehicles.

6.2. Collaborative distributed estimation and control

6.2.1. Networking protocols for estimation and control

Participants: A. Kibangou, A.L.F. de Almeida [Univ. Federal do Ceara].

As explained before, multiple access protocols such as Time Division Multiple Access (TDMA) can induce a latency that can be damaging for control purposes. In this case, Direct-Sequence Code Division Multiple Access (DS-SS) is certainly well indicated. In the last decade, by exploiting several diversities, new signal processing techniques based on tensor modeling have been developed. With a very high efficiency, they allow the blind estimation of transmitted information sequences [101], [110], [87], [80]. In general, these works are devoted to communication systems with an antenna array at the receiver. However, many wireless devices are limited by size, hardware complexity or other constraints to a single antenna. The powerful tensor based methods cannot be applied for such nodes. By resorting to the idea of collaborative signal processing, we have shown how estimating the channel, symbols, and codes in a distributed way when each node in the network has a single antenna. The received data samples can be stored in a three-way array, or a third-order tensor, admitting a PARAFAC model. In general, the parameters of the PARAFAC model are estimated using an Alternating Least Squares (ALS) algorithm. We have derived a distributed version of ALS where finite number of average consensus iterations are run between consecutive ALS iterations [34]. Some simulation results are depicted in Figs. 8 and 9 where we denoted by $D\text{-ALS}(i,j)$, the D-ALS corresponding to the i th

topology of connection with j consensus iterations. In Fig. 8, the NMSE is plotted as a function of the number of iterations. It can be seen that the connection topology impacts the convergence of the D-ALS algorithm. Connection topologies with greater connectivity degree have convergence properties (speed and final value) similar to those obtained with ALS.

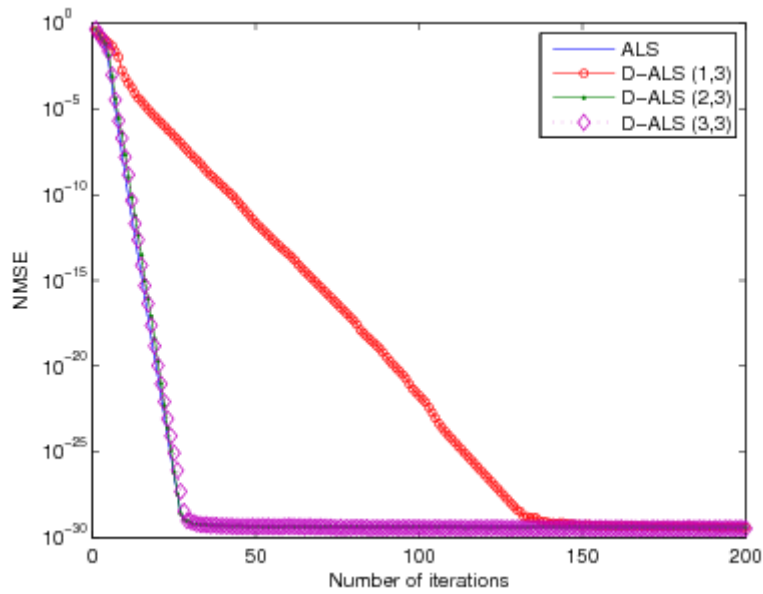

Figure 8. Median NMSE for $Q = 3$ and three consensus iterations.

In Fig. 9, we note that even for a single consensus iteration the D-ALS algorithm converges towards the same value than ALS. However, the convergence speed is lower. It can be accelerated by increasing the number of consensus iterations.

6.2.2. Quadratic indices for performance evaluation of consensus algorithms

Participants: F. Garin [contact person], S. Zampieri [Univ. di Padova], E. Lovisari [Univ. di Padova].

Average-consensus algorithms allow to compute the average of some agents data in a distributed way, and they are used as a basic building block in algorithms for distributed estimation, load balancing, formation and distributed control. The scenario is the following: there are N agents, each of which has a scalar value. Their goal is to reach an agreement (at least asymptotically) on the average of their initial values, by local exchanges of information. In fact, a graph describes which pairs of agents are allowed to communicate. A very popular algorithm to solve this problem is the linear average-consensus, which in discrete time is:

$$x(t+1) = Px(t)$$

where vector $x(t)$ has N entries corresponding to the current state of the agents, and P is a doubly-stochastic matrix.

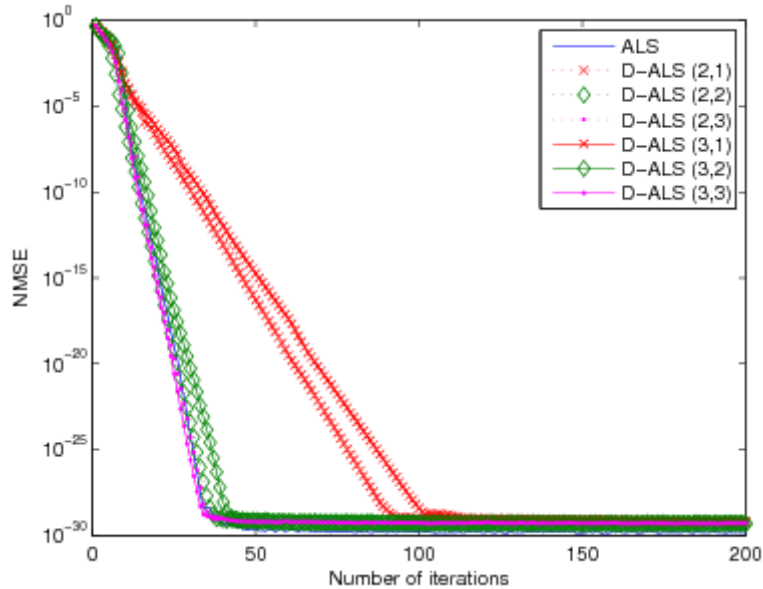

Figure 9. Median NMSE for $Q = 4$ and different number of consensus iterations.

Traditional analysis of linear average-consensus algorithms studies, for a given communication graph, the convergence rate, given by the essential spectral radius of the transition matrix (i.e., the second largest eigenvalues modulus). For many graph families, such analysis predicts a performance which degrades when the number of agents grows, basically because spreading information across a larger graph requires a longer time. However, if you consider other well-known quadratic performance indices (involving all the eigenvalues of the transition matrix), the scaling law with respect to the number of agents can be different. This is consistent with the fact that, in many applications, for example in estimation problems, it is natural to expect that a larger number of cooperating agents has a positive, not a negative effect on performance.

It is natural to use a different performance measure when the algorithm is used for different purposes, e.g., within a distributed estimation or control algorithm. Examples of various relevant costs can be found in the book chapter [76] and in the references therein.

We are interested in evaluating the effect of the topology of the communication graph on performance, in particular for large-scale graphs. Motivated by the study of wireless sensor networks, our main objective is to understand the limitations which arise when agents are limited to truly local interactions, i.e., the neighbourhoods are determined by being ‘near’ in a geometric (Euclidean) way, differently from graphs with few but possibly ‘distant’ connections, such as in small world models.

One example of cost is the evaluation of the transient by an LQ cost (expected ℓ_2 norm of the error) instead of by the dominant mode. When P is symmetric, this LQ cost can be re-written as $J = \frac{1}{N} \sum_{\lambda \neq 1} \frac{1}{1-|\lambda|^2}$. Note that the sum is over all the eigenvalues of P , it does not depend only on the well-studied second largest eigenvalue, and thus evaluating this performance metric requires new results in spectral graph theory. The first step in the analysis is to consider graphs which describe local interactions but are very structured, having a high symmetry and regularity which allows to use algebraic tools to evaluate the eigenvalues: regular (finite) lattices with periodic border conditions, i.e., grids over a d -dimensional torus (e.g., in dimension 1, a circle). Such graphs exhibit a dimension-dependent behaviour:

$$J(P) \sim \begin{cases} c_1 N & \text{if } d = 1 \\ c_2 \log N & \text{if } d = 2 \\ c_d & \text{if } d \geq 3 \end{cases}$$

Our aim is to prove that such a behaviour depends on the locality of interactions, not on the symmetries. To do so, we exploit a powerful tool, the analogy between reversible Markov chains and resistive electrical networks [69]. The main result is to recognize that the LQ cost is equal to the average effective resistance on a suitably defined networks of resistors. Then, we exploit the monotony of all effective resistances in the network with respect to variations of the resistance of single resistors, so that we obtain bounds on the cost for some quite irregular graphs, with respect to the known behaviour for the regular lattice. This work is described in [36] and [35].

6.2.3. Distributed Consensus algorithms

Participants: A. Seuret [Contact person], G. Rodrigues de Campos, D.V. Dimarogonas [MIT], K.H. Johansson [KTH].

Another effort has been devoted to the problem of controlling a set of agents cooperating under communication constraints. We consider a ‘‘consensus’’ algorithm as an interaction rule that specifies the information exchange between an agent and all of its neighbors over the network in order to reach an agreement regarding a certain quantity of interest that depends on the state of all agents. However, the use of a shared network introduces new challenges, such as delays over communications, packet losses or even communication blackout, which can dramatically affect ‘‘consensus’’ convergence rate and cooperative control laws efficiency.

It is well-known that introducing communication introduce delays and this delay generally leads to a decrease of the performance or to instability. Thus, investigating the impact of time-delays in the consensus problem is an important issue. In our research, we assume that each agent receives instantaneously its own output information but receives the information from its neighbors after a constant delay τ . The setup we considered leads to study the following equation $\dot{x}(t) = -\mu x(t) + Ax(t - \tau)$, where $\mu > 0$ and A is the classical adjacency matrix. These corresponds to a more realistic setup than the one usually considered in the literature [88]. More especially, in [99] and [91], we investigate the influence of the communication on the location of the agreement point and on the convergence rate, which is not straightforward when delays appear in the network. First, we proved that whatever the delay and whatever the graph, the set of agents will reach a consensus. The consensus equilibrium depends on the delay and on the initial conditions taken in an interval given by:

$$x_{eq} = U_2 \left(\lim_{s \rightarrow 0} s \frac{x(0) + \mu e^{-\tau s} \int_{-\tau}^0 x(u) e^{-us} du}{s + \mu(1 - e^{-\tau s})} \right) \vec{\mathbf{1}}.$$

where U_2 is a vector depending on the communication graph. Then, based on Lyapunov-Krasovskii techniques and LMI representation, an estimate of the convergence rate is provided. Figure 10 shows the examples of four communications graphs and Figure 11 shows the corresponding convergence rate.

It can be seen that the convergence rate strongly depends on the connection. Note that an interesting phenomena concerning the full connected network is pointed out. It is now well known that for some systems, delays could improve the performance and even lead to stability [92]. It thus appears that a set of full connected agents is one of those systems.

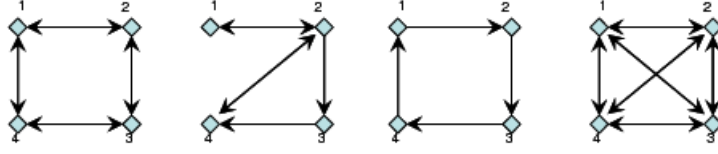

Figure 10. Four agents connected through various communication graphs

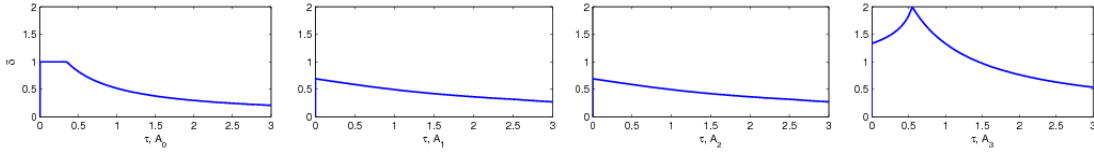

Figure 11. Evolution of the convergence rate δ with respect to the delay τ for various communication graphs

Another direction of research concerns agents obeying to a double integrator model. This model fits the behavior of real robotic agents more naturally, since such mechanical systems are controlled in most cases through their acceleration and not their velocity. However double integrator algorithms lead to several stability problems. For instance, if the graph is directed, the algorithm is not stable. We thus provide a novel consensus algorithm based on sampling approach. It appears that for some systems, delays or samplings have a stabilizing property. Thus we investigate in [39] on an appropriate modification of the consensus algorithm with a particular sampling of the form

$$\forall t \in [t_k, t_{k+1}[, \quad \ddot{x}(t) = -(L + \delta^2 I)x(t) + \delta^2 x(t_k) .$$

where δ and the sampling period T are parameters of the novel algorithm.

The stability analysis is proposed for any graph, represented by the Laplacian L , under the assumption that there exists a directed spanning tree included in the communication graph. We propose a method, based on linear matrix inequalities, to choose in a proper manner, the parameters δ and T for a given L .

Figure 12 shows the main simulation results for different values of δ and T . One can see, if $T = 0$, this algorithm is unstable for directed and undirected graph. Figure 12(c-d) show simulation results using the optimal pair (δ, T) according to our criteria, and the remaining figures show algorithm behavior for greater values of T . It's easy to conclude that for a too small or too important sampling period algorithm's performances decrease, and become unstable.

The new algorithm offers several advantages, since it reduces information quantity needed for control or quantity of sensors needed, witch means economical, space and calculation savings.

6.2.4. Distributed averaging over digital noisy networks

Participants: F. Garin [contact person], R. Carli [Univ. di Padova], G. Como [MIT], P. Frasca [Polit. di Torino].

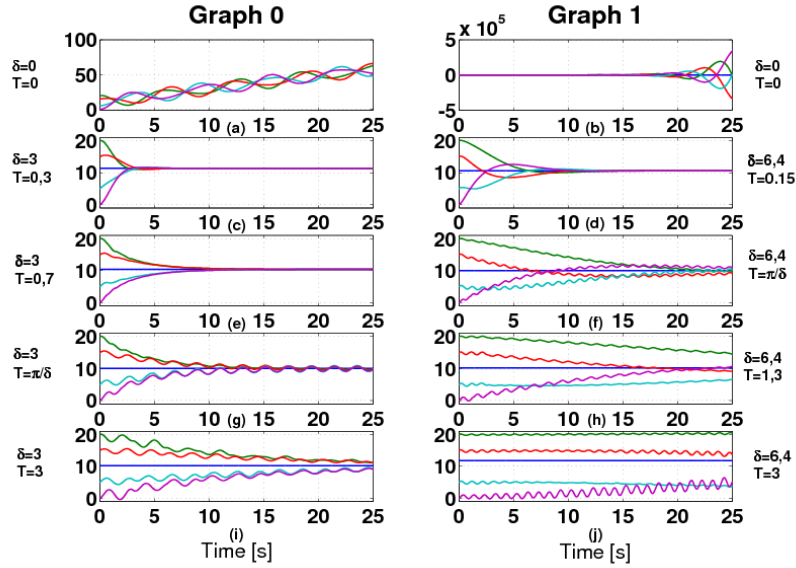

Figure 12. Evolution of the agents state for several values of the sampling period T

We study iterative distributed averaging algorithms for networks whose nodes can communicate through memoryless erasure broadcast channels. In order to compare the performance of different algorithms, we define suitable complexity measures, which account for the number of channel transmissions (communication complexity), and, respectively, of in-node computations (computational complexity) required to achieve a desired precision. These performance measures are particularly relevant, as they allow for directly estimating the energy consumption of such distributed computation systems, as well as their time-complexity.

The algorithms we propose combine the classical iterative linear consensus algorithm (see Section 6.2.2) with coding schemes for the reliable transmission of real numbers on noisy channels, recently proposed in [68]. They involve a sequence of transmission phases, of increasing duration, in which the agents attempt to broadcast their state, i.e. their current estimate of the global average, to their neighbors, alternated to averaging steps, in which the agents' states are updated. These algorithms are fully distributed, and they do not require the agents to have any global knowledge of the network structure or size. Our main result shows that such algorithms drive the agents to state agreement (consensus) which can be made arbitrarily close to the true average. The number of channel transmissions and in-node computations is shown to grow at most poly-logarithmically in the desired precision. We also show how communication feedback, when available, allows one to modify the algorithms, achieving asymptotic average consensus (i.e., state agreement on the average of the initial observations), and reducing the computational and communication complexities. This work is presented in the paper [14].

6.2.5. Formation control for a fleet of underwater vehicles

Participants: A. Seuret, C. Canudas de Wit [contact person], L. Briñón Arranz, B. Moore.

An effort has been devoted to the problem of controlling a set of agents, cooperating under communication constraints. Formation control of multi-agent systems is also considered and we focus on the translation control and uniform distribution of the agents in a moving circle.

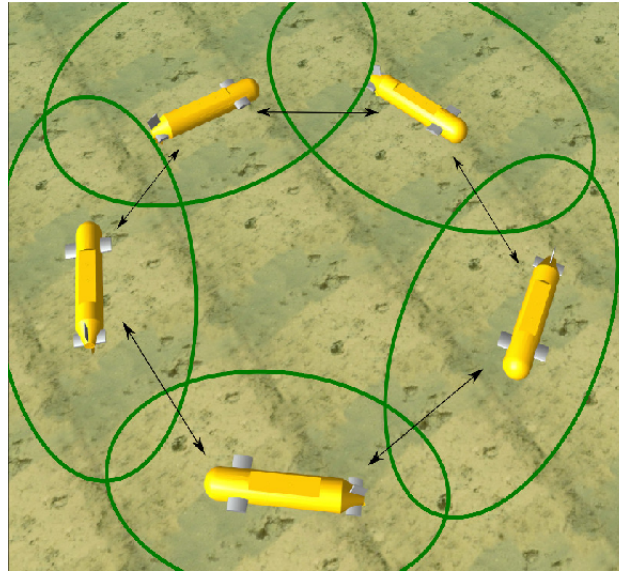

Figure 13. View of a fleet of AUVs with their communication range as displayed by Connectsim

A version of decentralized formation control for multiple mobile agents was analyzed based on a concept of alignment error and the optimization thereof. This resulted in the development of a type of consensus algorithm for which the total alignment error of the formation is monotonically decreasing [86]. Current research is focused on source seeking behavior for a fleet of AUVs. One part focuses on centralized continuous time outer-loop control for steering a circular formation of AUVs and another on discrete time decentralized control with information delays.

A first contribution in the context of source seeking problem consists in developing control laws to track time-varying formations of a fleet of AUVs (autonomous underwater vehicles). In [62] and [22], we propose two control algorithms to stabilize the AUVs to a circular formation with a time-varying center and with a time-varying radius respectively. The problem of the uniform distribution of the agents along the formation is also considered taking into account the communication constraints.

The objective now is to generalize this formation control approach in order to stabilize the agents to any time-varying formation including non circular formations. In [23], a general framework for formation control is proposed. In this paper, the affine transformations (translation, rotation and scaling) are introduced to define the desired trajectories known for all the agents. A velocity tracking control law is developed and a consensus algorithm is included to achieve the same formation. Based on this first result, an elastic formation control law is proposed. An elastic formation is a time-varying formation result from the application of the affine transformations to the unit circle. We tackle the uniform distribution of the agents along the formation problem using a cooperative control which includes the Laplacian matrix of the communication graph.

The future direction is to apply the gradient search algorithm from [86] to the elastic formation. We are working on a new collaborative source seeking control law based on [86], in order to include the communication constraints.

6.3. Stability and control design of asynchronous interconnected systems

6.3.1. Stability of sampled-data systems

Participants: A. Seuret [Contact person], C. Briat [Royal Institute of Technology], J. Gomès Da Silva Jr. [Univ. Federal do Rio Grande do Sul], W. Jiang, M.M. Peet [Illinois Institute of Technology].

NCS are controlled systems containing several distributed plants which are connected through a communication network. In such applications, a heavy temporary load of computation in a processor can corrupt the sampling period of a certain controller. The variations of the sampling period will affect the stability properties. It is now reasonable to design controllers which guarantee the robustness of the solutions of the closed loop system under periodic samplings. However the case of asynchronous samplings still leads to several open problems such that the guarantee of stability whatever the sampling period lying in an interval. In [98] and [28], we propose a novel approach to obtain sufficient asymptotic and exponential stability conditions of linear time-varying systems. Those conditions are based on the continuous-time approach but are based on the discrete-time Lyapunov theorem. The proposed theorems provide larger upper-bounds of the allowable sampling period than the existing ones (based on the continuous time approach). An additional characteristic of this framework is that it allows considering in a simple manner uncertainties and non linearities in the model as saturation in the control inputs. In [28] we also consider the case of communication delays. This study on sampled-data systems will be used in the sequel to improve the performance of distributed algorithms.

6.3.2. Stabilization via Communication Networks: A Time-Delay Approach

Participants: A. Seuret [Contact person], J.-P. Richard [LAGIS], E. Fridman [Univ. Tel Aviv], J. Gomès Da Silva Jr. [Univ. Federal do Rio Grande do Sul], K.H. Johansson [KTH].

A first contribution consists in developing novel type of tools able to assess stability of time-delay systems. In [97] and [94], we develop a new type of Lyapunov-Krasovskii functional whose parameters are defined using an arbitrary linear differential equation. In [15], we propose a method to design a memoryless state feedback control law which stabilizes neutral and delayed systems with saturated input. Concerning the stability of NCS under communication delays, we proposed in [10], [109] and [93], to use a time-varying horizon predictor to design a stabilizing control law that sets the poles of the closed loop system. The computation of the horizon of the predictor is investigated and the proposed control law takes into account the average delay dynamics explicitly. The resulting closed loop system robustness with respect to some uncertainties on the delay model is also considered. Tele-operation subject to time-varying delays has been considered in [7]. In [95] and [96], we also proposed an observer-based controller to ensure the stabilization of networked controlled systems. The main interest of such a controller concerns the potential to take into account the additional dynamics induced by the networks cited above. Further developments will take into account the quantification and the coding of the transmitted data packets.

6.3.3. Event-based control design

Participants: N. Marchand [Contact person], S. Durand.

Asynchrony is becoming more and more meaningful in modern control architectures and some new control strategies are being developed by some research teams in the world. The principle of these control laws is to compute a new control signal only when some event occur, where an event characterizes a change in the system and therefore a need for a new control. These approaches are supposed to reduce the number of times the control signal is computed and to remove the hard real-time constraint on the computational system. In this domain, our contribution is twofold. First, based on previous result from Nicolas Marchand [6], we proposed a fully asynchronous control scheme (without any time information) for chain of integrators that insures the global stability of the system with only measures when the states cross an *a priori* defined level. This work was presented at the IFAC world congress in Korea [85]. Secondly, we removed the safety limit condition introduced by K-E. Årzén in his event-based PID controller [111]. This safety limit was added to prevent the system to be sampled less than what Shannon theorem requires but we showed that the Shannon sampling condition is not consistent anymore in the context of event-based systems. This work is described in [74] and [70].

6.3.4. Control with adaptive variable sampling

Participants: D. Simon [contact person], O. Sename, E. Roche, M. Ben Gaid [IFP].

Control and real-time computing have been associated for a long time, for the control of industrial plants and in embedded or mobile systems, e.g. automotive and robotics [43]. However both parts, control and computing, are often designed with poor interaction and mutual understanding. We propose here an *Integrated control and scheduling co-design* approach, where closing the loop between the control performance and the computing activity is promising for both adaptivity and robustness issues ([44]).

In the past years we developed a variable sampling control methodology based on the LPV (Linear Parameter Varying) framework and H_∞ control synthesis, where the sampling interval is used as a known and controlled variable. Few assumptions about sampling are needed for this control design : the main point is that the control interval is known and lies between the predefined bounds $[h_{min}; h_{max}]$, whatever the origin of the control interval variations, its speed and its frequency.

The initial approach has been cleaned in [8]. Beyond the initial goal, where the control interval is assumed to be controlled and known, case study simulations show that the method has a good robustness w.r.t. unmodelled delays, such as latencies due to networking, computing and preemption activities ([45]). Further work plans to specifically analyse, understand and exploit this robustness.

However, the computational complexity of the initial approach, based on polytopic models of the uncertain system, is expected to grow fast with the number of uncertain parameters in the plant. A new formulation of varying sampling, in the framework of the LPV methodology, has been developed using a Linear Fractional Transform (LFT) where it is expected that the varying control interval and the plant's uncertain parameters can be both considered. The objective is to transform the system under the form described in Figure 14 where matrix Δ represents the uncertainties depending on the sampling period h .

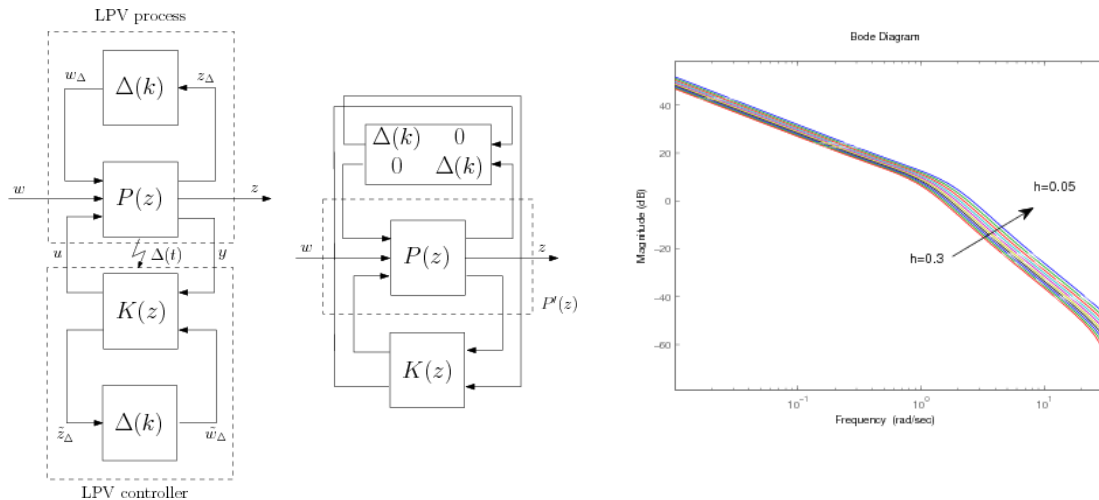

Figure 14. LFT control scheme and sampled system Bode diagram

The varying sampling controller is synthesized using the LFT model, in the LPV/ \mathcal{H}_∞ framework by the resolution of LMIs handling both the nominal model, the uncertainties model and the control objectives ([38]). Note that the weighting templates used in the \mathcal{H}_∞ control design are also made sampling dependent, to avoid a too high performance demand when the sampling rate is slow.

6.3.5. Robust control of underwater vehicles

Participants: D. Simon [contact person], O. Sename, E. Roche, S. Varrier.

In the framework of FeedNetBack projects, the LFT/ \mathcal{H}_∞ approach has been applied to the control of an AUV.

The 3D coordinated control of an autonomous underwater vehicle is not straightforward : indeed the model of the vehicle has important non-linearities and several poorly known parameters which lead up to robust control. Moreover the limited capabilities of underwater acoustic links and limited embedded computing power and on-board energy induced serious timing disturbances and scheduling constraints. These problems make AUVs good testbeds for control/computing co-design.

An LPV/LFT model of the AUV considering the sampling period as varying parameter, using the methodology previously described has been built. From the linearized model of the AUV, a discretized model according to a varying sampling rate is obtained thanks to a Taylor series expansion, where the parameter block Δ has a direct dependence on the varying sampling period δ . The Bode diagram of this LPV/LFT system (Figure 14) shows a variation on the system gain and also on the bandwidth according to the current value of the sampling interval.

Simulation results show that this LPV/LFT controller provides stable control with performance compliant with the specification for all the desired range of sampling interval variation (while a pure \mathcal{H}_∞ fails to stabilize the system for slow sampling rates).

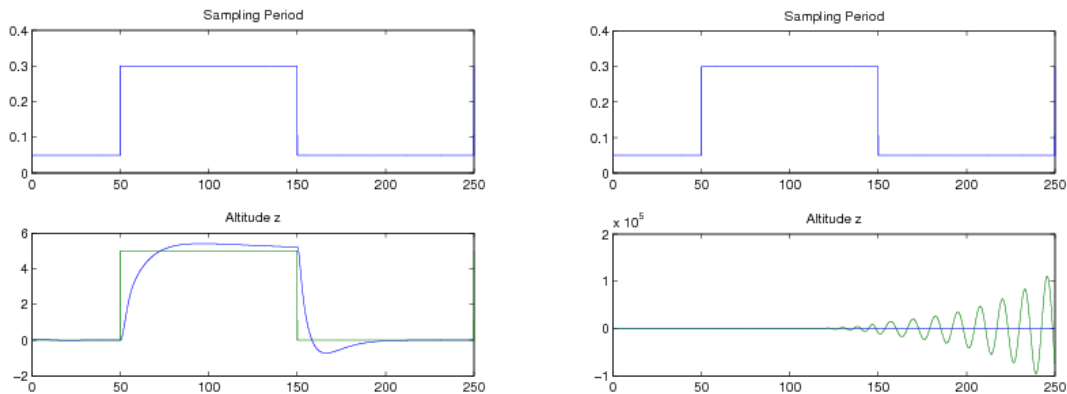

Figure 15. Test 3: Altitude z step variation of h : LPV/LFT (left) and \mathcal{H}_∞ (right)

The classic way to design an altitude controller has been used considering a model representing the transfer between the desired output (altitude z) and the reference z_{ref} . Indeed this direct method does not well take into account the structure of the vehicle and particular actuators (front and rear fins). This leads to difficulties in the tuning of the control parameters, and does not allow to handle their limitations. Therefore an alternate kind of control has been developed [59]. It is a cascade structure, taking into account that altitude motions are basically the result of pitch angle variations. This cascade structure helps in control parameters tuning and easily allows for the introduction of anti-windup to fight actuators saturation. The application of LPV varying sampling for this enhanced cascade control structure is under investigation [89].

6.3.6. Control architecture and tools

Participants: D. Simon [contact person], R. Pissard [SED], S. Arias [SED], E. Rutten [SARDES], F. Boudin.

The observation and characterization of implementation-induced distortions on feedback controllers is usually beyond the capabilities of traditional simulation tools like Matlab/Simulink or Scilab. These lacks have motivated the deployment of a specialized toolbox, to integrate models of operating systems and networks inside control-dedicated existing simulation tools. As these tools provide modellers, they can be used for fast prototyping and problems spadework.

However these approaches remain simulations and are still quite far from a real implementation. Another drawback is slow simulation speed, due to complex models involving a mix of continuous and discrete dynamics, that can be a handicap to study realistic scenarii. On another hand it appears that hardware-in-the-loop simulation (merging the real hardware/software targets and a simulated plant) is able to provide faster (real-time) simulations and is a useful last step before integration and tests on a real system.

ORCCAD is an integrated development environment aimed to bridge the gap between advanced control design and real-time implementation. Although it has been developed years ago, the basic concepts upon which the ORCCAD architecture relies still appear to be solid in the field of software development for robot control [42], it still compares well with other tools dedicated for real-time control implementation [106] and is expected to provide the missing link between simulations and experimentation [53].

In the framework of the SafeNECS ANR project, a hardware-in-the-loop experiments using ORCCAD has been set up to provide a safe environment for both algorithms and software validation, prior to experiment with the real (expensive and fragile) quadrotor. Figure 16 describes the control and diagnostic setup used for testing purpose [48]. For example it may be used to implement a (m,k)-firm dropping policy ([78]) or hybrid priority schemes over the CAN bus [46].

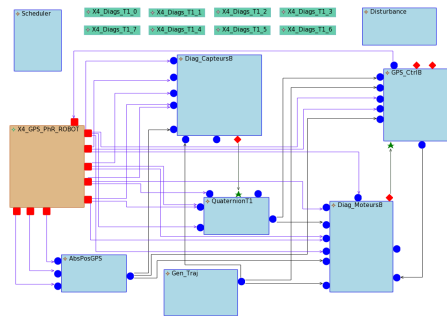

Figure 16. Control and diagnosis block-diagram

To fulfill the control performance objectives together with safety and dependability constraints, the feedback control data flow must be linked with discrete event controllers, aimed to handle exception handling as well as complex mission programming based on elementary actions scheduling. This layer up to now uses programming and synchronous composition with the ESTEREL language coupled with formal verification tools. An alternative approach is currently carried out in collaboration with the SARDES team. Rather than using programming then verification, the new approach aims at using discrete-event control synthesis to build directly safe controllers from the system specification rules and control objectives [51].

6.4. Energy-aware control of systems on chip

6.4.1. Energy-aware computing power control

Participants: N. Marchand [contact person], S. Durand.

Achieving a good tradeoff between computing power and energy consumption is one of the challenges in embedded architectures of the future. This management is especially difficult for 45nm or 32nm known to be at the limit of the scalability, i.e., with a high process variability (see [41] for further details). Automatic control loops have therefore to be designed in order to make the performance fit the requirement in order to minimize the energy loss in a context of highly unknown performance of the chip. The main objective is to dynamically control the computing power and the consumption using the voltage and the frequency according

to the requirements of the OS. In this way, a robust control law was developed [73] in order to minimize the high voltage running time with predictive technique, i.e. to minimize the energy consumption. Results are shown on figure 17 where the robustness is illustrated for 10% and 20% of process variability.

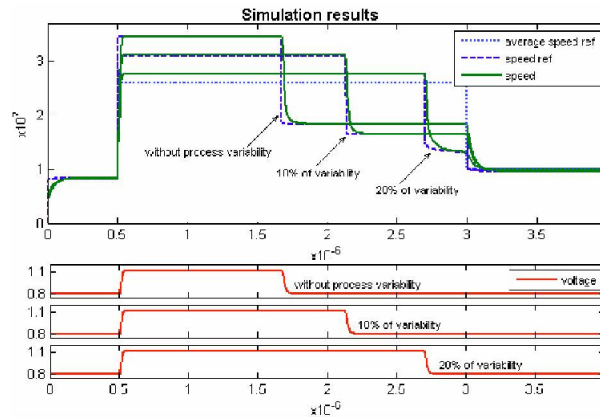

Figure 17. Energy controller simulation results

This control was done for one node (i.e. a processor) but in ARAVIS SoC, the chip is composed of several clusters with several nodes each (see figure 18). Thus, the energy controller has to manage the voltage level (one voltage domain by cluster) and the frequency for all nodes: a maximal frequency is performed for critical node and then a ratio of this frequency could be apply to the other nodes. Thus, a multicore control strategy with low computational needs was proposed [72].

Two patents have been deposited: the first one for the monocoenergy control [71] and the second one for the multicore energy control [75].

6.4.2. Video decoding QoS control

Participants: D. Simon [Contact person], A.-M. Alt.

An application software deployment based on a static and worst case point of view is no longer effective for such heterogeneous chips and more flexible designs must be used. It appears that closed loop control can be integrated at several hardware and software levels of the chips to provide both adaptivity to the operation conditions and robustness w.r.t. variability.

On top of the clusters power control and computing speed control layers, the outer application layer includes a feedback loop to control the application quality of service (QoS) under constraints of computing and energy resources availability. This loop uses the scheduling capabilities provided by the operating system to control the application's execution parameters. In the particular context of a H.264/SVC decoder expected to run on the ARAVIS, the computing speed of each node is a controllable scheduling parameter, as well as the deadlines assigned to decode every frame. A prototype has been implemented on a stock Linux laptop using the event-based programming model provided by the SARDES team : it shows the effectiveness of the approach where very simple closed-loop controllers allow for saving computing energy while preserving a good video decoding quality [13].

6.5. Highway traffic model-based density estimation

Participants: C. Canudas de Wit [Contact person], C. Irinel-Constantin Morarescu.

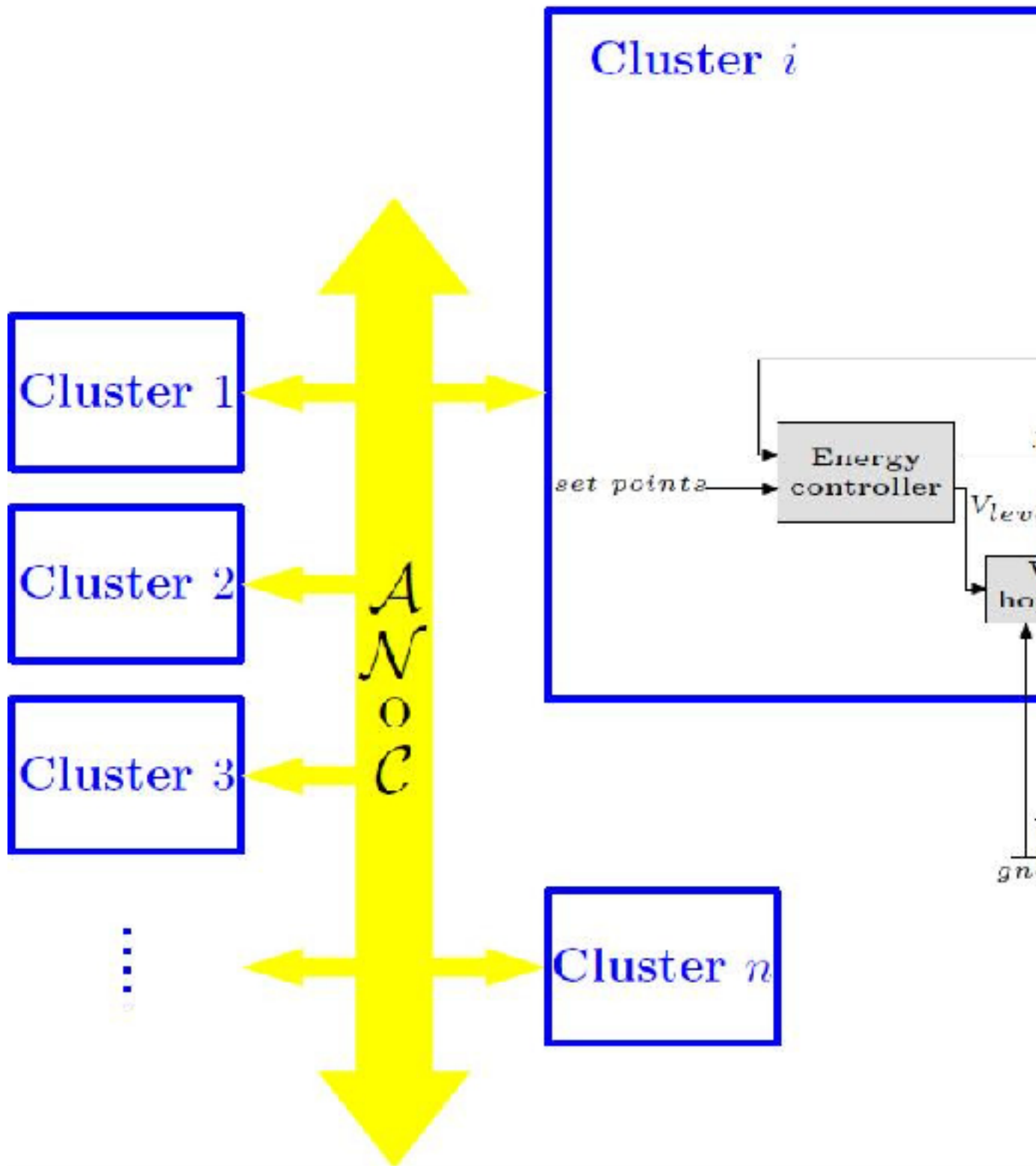

Figure 18. ARAVIS SoC architecture

The work developed by the NeCS team in this direction consists of several tasks. Firstly, we have calibrated a microscopic model, under Aimsun microscopic simulator, in order to reproduce the traffic behaviour on the south ring of Grenoble. The microscopic model has been used to produce a database of measures considering real traffic state measures. Secondly, we defined our constrained deterministic macroscopic model, with a fundamental diagram based on the microscopic simulations. The main advantage of a macroscopic model are: the reduced number of parameters that must be calibrated and the high simulation speed. The constrained model is used to reduce the number of possible affine dynamics of the system and preserve the number of vehicles in the network. Thirdly, we have designed a forward/backward observer that allows to accurately recover the densities (number of cars) in the cells along the network and precisely localize the eventual congestion front. Finally, Matlab numerical simulation show the efficiency of the designed observer.

6.6. Modeling and control of web servers

Participants: N. Marchand [contact person], L. Malrait, S. Bouchenak [SARDES].

This work focuses on the design of a server model, the design of admission control laws that allow the server to satisfy different Service Level Objectives, and the implementation of the latter. This work is in collaboration with SARDES team at INRIA, and is the topic of the Ph.D. thesis of Luc Malrait.

The first part of the work consisted in designing a continuous time model using a fluid flow approach. This model is then used for control purposes. We implemented this contribution on a real system which emulates an e-business environment [17].

We are currently working on how this approach can be extended to multiserver systems, in the context of a new starting ANR project MyCloud.

6.7. Observers design for multi-sensor systems: application to HDI engines

Participants: C. Canudas de Wit [contact person], R. Ceccarelli.

Research activity in vehicle industry targets pollutant emission reduction. Homogeneous charge compression engine ignition (HCCI) is an interesting alternative to this problem. New European community laws impose new stringer constraints to pollution, and as a consequence, forces the car industry to realize on board diagnosis system in order to detect engine failures that may result in an increase in the engine pollution. The control of pollutant emission, in diesel engine, is ensured by exhaust gas recirculation system (EGR). Its functioning is very important and a fault detection and isolation system (FDI) is necessary in order to ensure good performances and poor emissions. Exhaust gas could be taken before or after compressor: respectively called high and low pressure EGR.

In this project carried out in collaboration with the IFP (Institut Français du Pétrole), we aim at developing model-based observer allowing to identify several types of engine failures, like: gas leakage in the low and high pressure recirculation circuits, ill functioning of some of the sensors, and actuators (valves).

The first year has been dedicated to system modeling with respect to leakage detection and estimation. In a first phase, leakage in intake receiver has been studied by the mean of two different nonlinear adaptive observers. The observers have been tested on a experimental engine testbed. For this first application, no differences come out from the use of these two observers [64]. The second part of the work is dedicated to the design of a variable threshold in order to be less conservative and avoid false alarms. For this purpose, we are investigating a study of possible causes (modeling and measures error) whose effect drive leakage estimation away from the correct value [65].

The second year has been devoted to the application of the previously proposed approach to a different part of the Diesel air-path system: the turbocharger. The aim was the detection of the turbine efficiency loss in order to guarantee the correct amount of air needed to the combustion. A complete sensitivity study has been carried on the turbocharger subsystem to generate a variable threshold and determine working points where the detection is insensitive to possible measurement biases. The system has been successfully tested in simulation along the standard european car cycle [66].

In the third and last year of the PhD thesis, we worked on the experimental validation of the previously results. Moreover, a multi-faults detection strategy, based on the recursive least square algorithm, has been investigated in order to improve the adaptive threshold robustness.

7. Contracts and Grants with Industry

7.1. Grants and contracts with Industry

7.1.1. IFP

Accompanying contract with IFP (Institut Français du Pétrole), in the framework of the CIFRE PhD grant of Riccardo Ceccarelli (2007-2010). The goal sought with the Control Engine Dept. of IFP is the development of a model-based observer allowing to identify several types of engine failures. The first year has been dedicated to system modeling with respect to leakage detection and estimation. In a first phase, leakage in intake receiver has been studied by the mean of two types of nonlinear adaptive observers. The observers have been tested on a AMÉsim - Simulink co-simulation environment. For this first application, no differences come out from the use of these two observers. The second part of the work is dedicated to the design of a variable threshold in order to be less conservative and avoid false alarms. For this purpose we are investigating the possible causes (modeling and measurement error) whose effects drive leakage estimation away from the correct value. Then, the previously proposed approach has been applied to a different part of the Diesel air-path system: the turbocharger. The aim was the detection of the turbine efficiency loss in order to guarantee the correct amount of air needed to the combustion. A complete sensitivity study has been carried on the turbocharger subsystem to generate a variable threshold and determine working points where the detection is insensitive to possible measurement biases.

7.1.2. AIRBUS

Accompanying contract with AIRBUS in the framework of the Cifre PhD grant of Patrick Andrianiaina. The goal of this PhD thesis is to study flexible implementation methods for real-time controllers, aimed at reducing the conservatism induced by the current approach purely based on worst case considerations [60].

7.2. Technology transfer: start-up Karrus

The NeCS team is continuing its activity in road traffic modeling and control. The expected scientific contribution of NeCS in this field concerns the development of new estimation prediction and identification algorithms based on the measurements collected through sensor networks installed on freeways. The team study also the problems of time-to destination and control algorithms for ramp metering. The team is currently setting up a consortium with local authorities involved in traffic management to build to demonstrator called GTL for Grenoble Traffic Lab. One target of this activity is to transfer part of the developed technology to a start-up named Karrus and led by Denis Jacquet (<http://www.karrus.fr/>). The start-up was created in January 2010.

8. Other Grants and Activities

8.1. Regional Initiatives

8.1.1. Pôle de compétitivité Minalogic/ARAVIS.

ARAVIS (Architecture reconfigurable et asynchrone intégrée sur puce) is a project sponsored by the Minalogic Pole, started for 3 years in October 2007 (http://www.minalogic.com/PAR_TPL_IDENTIFIANT/903/TPL_CODE/TPL_PROJET/31-recherche.htm). The project has been extended to december 2011. It investigates innovative solutions needed by the integration of 22 nano-meter scale future chips. It is headed by STMicroelectronics, the other partners are CEA-Leti, TIMA laboratory and the SARDES and NECS teams at INRIA.

8.1.2. *Pôle de compétitivité Minalogic/SmartEnergy.*

Smart Energy is a project proposal, now under evaluation, which has obtained the double labellisation Minalogic and Tenerrdis. The project leader is Schneider Electric, and there are 14 participants, (partly academic and partly industrial) from the Grenoble area. The NeCS team participation concerns distributed estimation and fault detection. If funded, the project will start in Spring 2011.

8.2. National Initiatives

8.2.1. *ANR PsiRob CONNECT*

The CONNECT proposal (**CON**Trol of **NE**tworked **CO**operative **sys**TEms) deals with the problem of controlling multi-agent systems, i.e., systems composed of several sub-systems interconnected between them by an *heterogeneous* communication network. The control of a cluster of agents composed of autonomous underwater vehicles, marine surface vessels, and possibly aerial drones will be used as a support example all along the proposal. The partners are the NeCS team, Ifremer robotics lab. and the ROBOSOFT and Prolexia companies. It started in May 2007, for a duration of 3 and a half years; the project will end on February 2011. More information can be found on-line: <http://www.lag.ensieg.inpg.fr/connect/>.

8.2.2. *ANR VOLHAND*

C. Canudas de Wit, in collaboration with Franck Quaine and Violaine Cahouët (from the biomechanical team of GIPSA-Lab) is involved in a project named VOLHAND, funded by the ANR, which has started in October 2009. The project aims at developing a new generation of Electrical power-assisted steering specifically designed for disabled and aged people. Our contribution is to work out new assisted laws that accommodate to the specific mechanical characteristics of this particular driver population. The consortium is composed by: LAMIH, CHRU, Fondation Hopale, GIPSA-Lab, INRETS and JTEKT. This project is in collaboration with the biomechanical team of GIPSA-Lab.

8.3. European Initiatives

8.3.1. *FeedNetBack*

The FEEDNETBACK proposal has been accepted as a STREP project at the FP7-ICT-2007-2 call in October 2007. It is coordinated by Carlos Canudas de Wit and gathers researchers from academia (INRIA-NeCS, ETH Zurich, Universidad de Sevilla, KTH Stockholm, Università di Padova) and from industry (Ifremer, Vodera, Vitamib, Intellio and OMG).

The main objective of the FeedNetBack project is to generate a rigorous co-design framework that integrates architectural constraints and performance trade-offs from control, communication, computation, complexity and energy management. The goal is to master complexity, temporal and spatial uncertainties such as delays and bandwidth in communications and node availability. This approach will enable the development of more efficient, robust and affordable networked control systems that scale and adapt with changing application demands. The project will extend the current scientific state-of-the-art in networked control and develop a set of software tools to support the co-design framework. To demonstrate the potential and limitations of the new technology, FeedNetBack will apply it on two industrial test cases of realistic complexity and scale: underwater inspection systems based on fleets of Autonomous Underwater Vehicles (AUVs), and surveillance systems using a network of smart cameras. The control component is essential in both test cases as they require cooperation of distributed objects to achieve a common goal (<http://feednetback.eu/>). Specific issues that will be addressed in the project include:

- Heterogeneity: The sensor hardware and the communication means may be of different natures (different noises, bandwidths, resolution characteristics, etc.).
- Mobility: Sensor location may not be fixed. Dynamic location of sensors will lead to varying topologies.

- Resource management: The energy and computation capabilities of each node are generally limited.
- Scalability: Wireless sensor networks may comprise hundreds or thousands of nodes. It is therefore crucial that the complexity of the design procedures and the resulting controllers scale slowly with the number of nodes.
- Asynchrony: Information exchange between sensor/control units may not be synchronous in time.

Since in NCS the goal is to ensure satisfactory performance of the overall closed loop system, these problems are treated holistically through sets of performance constraints.

The co-design framework aims at controlling more complex systems with a fraction of the effort, while increasing availability and reliability. The framework will enable application developers, programmers and systems integrators to fully use the potential of networked control in a wide set of industrial domains. Examples of areas where an impact is expected are the fields of factory automation, public infrastructure safety and security, transport and building maintenance.

FeedNetBack will go beyond developing new technologies, but will also apply these technologies to areas of society where they protect the environment and improve people's safety, security and ultimately quality of life.

8.3.2. Hycon2

HYCON2 (Highly-Complex and Networked Control Systems) is a Network of Excellence, within the European Union's FP7. It has started on Sept. 2010, for a duration of three years. Coordinated by Françoise Lamnabhi-Lagarrigue (L2S-CNRS), it involves 26 academic institutions from all over Europe.

ICT developments both enable and enforce large-scale, highly-connected systems in society and industry, but knowledge to cope with these emerging systems is still lacking. HYCON2 will stimulate and establish the long-term integration of the European research community, leading institutions and industry in the strategic field of control of complex, large-scale, and networked dynamical systems. It will interconnect scattered groups to create critical mass and complementarity, and will provide the necessary visibility and communication with the European industries. HYCON2 will assess and coordinate basic and applied research, from fundamental analytical properties of complex systems to control design methodologies with networking, self-organizing and system-wide coordination. HYCON2 has identified several applications domains to motivate, integrate, and evaluate research in networked control. These domains are ground and aerospace transportation, electrical power networks, process industries, and biological and medical systems. Benchmarking will serve as a tool for testing and evaluating the technologies developed in HYCON2 and for stimulating and enforcing excellence by the identification and adoption of best practices. In particular, two show-case applications corresponding to real-world problems have been selected in order to demonstrate the applicability of networked control and the need for research in control. As no substantial technological breakthrough can be achieved without preparing the proper cultural background, a further important objective of HYCON2 is to spread and disseminate excellence through multi-disciplinary education at the graduate and undergraduate level. The proposed research, integration and dissemination program will make Europe both the prominent scientific and the industrial leader in the area of highly complex and networked control systems, therefore posing Europe in an extraordinary position to exploit their impact in economy and society.

The NeCS team is mainly involved in the first show case application, which corresponds to the operation of the **freeway network around the Grenoble area**. The recent advent of new vehicle sensing technologies provides an opportunity for innovative control applications in traffic management. The Grenoble Traffic Lab (GTL) initiative, lead by the NeCS team, has the ambition to equip massively the Grenoble south beltway with wireless magnetometers. The availability of such a reliable sensor network, designed primarily with control applications in mind, will allow to see control systems used in the field of freeway management. Control systems in road transportation are primarily involved in the management of traffic lights in urban (city corridors), and inter-urban sectors (rings highways). The target of most of the efforts in the domain is to improve the freeway efficient in an equal way to all drivers. The goal of this show case is to provide a rich set of field traffic data to the control community in order to test their algorithms on a practical real-world problem. These data will be available through a web server administered by INRIA along with all the maps describing

finely the freeway under study. Historical and real time data will be available. All these data will be ready for experiments and the outcomes can be provided to the road operators to judge the relevance and efficiency of the results for operational use.

8.4. National and international scientific collaborations

8.4.1. Collaborations inside Inria

- The Ph.D. thesis of Luc Malrait is co-advised by S. Bouchenak, of the INRIA team SARDES.
- The NeCS team is a partner in the Sensas A.D.T. (started in December 2010), where it is involved in the coordinated control of a networked swarm of mobile robots.

8.4.2. Cooperations with other laboratories

Long term collaboration does exist with the University of Sevilla along several different topics including: coding and control co-design, Power control in NCS, energy-aware control in SoC, and control of CD and AC converters. Scientific collaborations inside the IST FeedNetBack project have been initialized with ETH Zurich and University of Sevilla about the integration of control and scheduling on distributed architectures, in particular focusing on the robustness and predictive control point of views. The ANR SafeNecs project provided support and collaboration along the three past years with teams from both the computing side (LORIA Trio team about control and (m,k)-firm scheduling) and from the fault tolerant control side (CRAN Nancy and Gipsa-lab, about the integration of real-time control, diagnosis and flexible scheduling).

Strong collaborations have been established with KTK (Stockholm), ETH (Zurich), University of Sevilla and Padova as core partners of the FeedNetBack European project.

- Carlos Canudas de Wit has collaborations with University of Sevilla (F. Gomez-Estern, F. R. Rubio, F. Gordillo, J. Aracil), University of New Mexico (C.T. Abdallah), and Lund Control system department (K.J. Astrom)
- A. Seuret has collaborations with LAGIS (J.-P. Richard), Leicester University (C. Edwards), University of Kent (S.K. Spurgeon), Tel Aviv University (E. Fridman), UFRGS (J.M. Gomes da Silva Jr.), with KTH (K.H. Johansson, D.V. Dimarogonas, C. Briat) and with Illinois Institute of Technology (M.M. Peet)
- A. Kibangou has collaborations with I3S (G. Favier) and Universidade Federal do Ceara (A.L.F. de Almeida)
- F. Garin has collaborations with Università di Padova (R. Carli, E. Lovisari, S. Zampieri) and Politecnico di Torino (P. Frasca, F. Fagnani) in Italy, and with MIT (G. Como).

9. Dissemination

9.1. Animation of the scientific community

- The NeCS team has organized the 2nd IFAC Workshop on Distributed Estimation and Control in Networked Systems (<http://necsys2010.inrialpes.fr/>), an international workshop which was held in Annecy on Sept. 13-14th. Moreover, it has organized the 2nd FeedNetBack Annual Workshop (<http://necsys2010.inrialpes.fr/satellite-event/>), with one day of Open Workshop (<http://www.feednetback.eu/Workshops/workshop-description/>) with scientific presentations both from people involved in the FeedNetBack project and from invited speakers, followed by one day of review meeting for the project and a Junior Workshop for FeedNetBack Ph.D. students and postdocs.

- Carlos Canudas de Wit was the general chair of the IFAC Conference on Networked Controlled Systems NeCSYS 2010.

He participated to several concertation meetings in the CORDIS reseach program at the ITC-department in the EU. He also participated in the “International Workshop on Future of Control in Transportation Systems” at Sorrento, Italy, on May 29th 2010 (<http://iee-iefct.unisannio.it/>). The Workshop was sponsored by the the IEEE Control Systems Society, and by our FeedNetBack EU project. A report will be available on the CSS published by the IEEE Control Systems Magazine.

He participated as evaluator (Dec. 2009–Jan2010) in the FP7 program “Factories of the Future”: FP7-2010-NMP-ICT-FoF, and as reviewer of EU projects in the FP6 program on Embedded Systems and Control (May 2010). He was co-author of the book “Dry clutch control for automotive applications” together with P. Dolcini, and H. Bechart, in Springer, AIC series, 2010.

- F. Garin was publications co-chair for the NecSys’09, and the organizer of the Junior Workshop at the FeedNetBack review meeting. She has been a peer-reviewer for international journals (IEEE Trans. on Control, IEEE Trans. on Communic.) and conferences (CDC 2010, NecSys 2010, ACC 2011, IFAC World Congress 2011)
- A. Kibangou was a member of the Technical Program Committee of the European Signal Processing Conference (EUSIPCO) 2010. He co-chaired publications in the organization committee of the 2nd IFAC Workshop on Distributed Estimation and Control in Networked Systems (Necsys) . He serves as a reviewer for the following international journals: Signal Processing (Elsevier), IET Signal Processing, Journal of the Franklin Institute, Electronics Letters, Int. J. Modelling, Identification and Control, and also for the national journal e-STA. He served as reviewer for IFAC World Congress 2011, DYCOPS 2010 (International Symposium on Dynamics and Control of Process Systems), ISWCS (International Symposium on Wireless Communication Systems) 2010, and CIFA (Colloque Internationale Francophone d’Automatique) 2010. He was among the contributors of the trilateral cooperation SVA (Separation of Variables and Applications) sponsored by CNRS (France), RFBR (Russia), and DFG (Germany). Locally, he is the organizer of seminars for the Control Department of GIPSA-LAb. For the Carnot Insitute LSI, he was member of the “Sensor Networks Initiative” of the ICT-MNT Carnot alliance. In this framework, he was a contributor to a white book devoted to the vision of the ICT-MNT Carnot alliance on Internet of things.
- O. Sename is member of the IFAC Technical committees ‘Linear systems’ and ‘Automotive control’, and develops some formal international collaborations with Hungary and Mexico. He is responsible of the French ANR project INOVE 2010-2014.
- A. Seuret is co-animator of the “Time-delay System” group (GDR SAR) since March 2008. He is leader of a Workpackage of the European Project FeedNetBack. He has been the vice-general chair for the NecSys’10, and he has been a member of the International Program Committee of the IEEE Conference on Control and Application (CCA’09) and of the IFAC Workshop on Time-delay Systems (TDS’10). He is also reviewer for the major Journals and Conferences of the field. Among them, there are journals (IEEE Trans. on Automatic Control, Automatica, System Control and Letter, International Journal of Systems Science), conferences (Conference on Decision and Control (CDC), American Control Conference (ACC), IFAC Workshops on Robust Control (ROCOND) and on Time Delay Systems (TDS)).
- D. Simon is member of the RTNS’10 (international conference on Real Time and Network Systems) program committee. Publication chair for the NecSys’10 (Estimation and Control of Networked Systems) IFAC workshop. Reviewer for the PhD defence of I. Diouri (CRAN Nancy, October 2010). Reviewer for the Discrete Event Dynamic Systems and Control Engineering Practice journals. (Grolon).

9.2. Teaching

9.2.1. Courses

- Alain Kibangou teaches Mathematics and Automatic Control at IUT1 Grenoble (University Joseph Fourier). He is in charge of the Automatic control Lab.
- Alexandre Seuret teaches Automatic Control at Grenoble-INP ('Master 1' and 'Master 2', 40h). He organizes the summer school of GIPSA-Lab on Automatic Control; the Summer School for 2010 was on Distributed control and estimation of networked control systems, with the scientific direction of S. Zampieri (University of Padova, Italy) and world-reknown lecturers, see http://www.gipsa-lab.inpg.fr/summerschool/auto2010/index_en.php
- O. Sename teaches Robust Control (20h) and Time-delay systems (14h) in the M2R Automatique Master at Grenoble INP; he is in charge for the 2-years engineering program in Automatic Control, Systems and Information Technology in Grenoble INP /ENSE3 .
- Nicolas Marchand teaches *Nonlinear control systems*, Master PSPI, Université Joseph Fourier, and *Control of Embedded systems*, Filiere SLE, ENSIMAG, Grenoble-INP. He is also is in charge of the PhD program in automatic control of the doctoral school EEATS.

9.2.2. Advising

Postdocs:

- Alireza Farhadi (INRIA, Aravis project, from Jan. 2010), advised by C. Canudas de Wit,
- Federica Garin (INRIA, Aravis project, from March to Oct. 2010), advised by C. Canudas de Wit,
- Wenjuan Jiang (LSI Carnot Institute, until Aug. 2010), co-advised by C. Canudas de Wit and O. Sename,
- Constantin Morarescu (CNRS, Connect projec, until Sept. 2010), advised by C. Canudas de Wit.

PhD students:

- Carolina Albea-Sanchez, co-advised by C. Canudas de Wit and F. Gordillo (Univ. Sevilla), 2007/2010,
- Patrick Jocelyn Andrianiaina is advised by D. Simon, Grenoble INP, Airbus Cifre, 2010/2012.
- Lara Briñón Arranz, co-advised by C. Canudas de Wit and A. Seuret, INRIA, FeedNetBack project - 2008/2011,
- Nicolas Cardoso de Castro, advised by C. Canudas de Wit and from Sept. 2010 co-advised by F. Garin, INRIA, FeedNetBack project - 2009/2012,
- Riccardo Ceccarelli, co-advised by C. Canudas de Wit and A. Sciaretta(IFP), 2007/2010,
- Valentina Ciarla, co-advised by C. Canudas de Wit, Franck Quaine (UJF) and Violaine Cahouet (UJF), CNRS, Volhand project - 2010/2013,
- Sylvain Durand, co-advised by N. Marchand and D. Simon, Grenoble INP, 2007/2010,
- Luc Malrait, co-advised by N. Marchand and S. Bouchenak (SARDES), Grenoble INP, 2007/2010,
- Émilie Roche, co-advised by O. Sename and D. Simon, INRIA, FeedNetBack project - 2008/2011,
- Gabriel Rodrigues de Campos, co-advised by A. Seuret and C. Canudas de Wit, Grenoble INP, 2009/2012.

Master students:

- Grégory Pichonnier (CNAM thesis), advised by Carlos Canudas de Wit,

- Diana Stefan, advised by Carlos Canudas de Wit,
- Florent Stevenin, advised by Carlos Canudas de Wit,
- Javier Tordesillas Illan, advised by Carlos Canudas de Wit, Vohland project,
- Sébastien Varrier, co-advised by O. Sename and D. Simon, Grenoble INP.

10. Bibliography

Major publications by the team in recent years

- [1] C. AUBRUN, D. SIMON, Y.-Q. SONG. , C. AUBRUN, D. SIMON, Y.-Q. SONG (editors) *Co-design Approaches for Dependable Networked Control Systems*, ISTE Wiley, 2010, <http://hal.inria.fr/inria-00443847/en/>.
- [2] C. CANUDAS DE WIT, F. GOMEZ-ESTERN, F. RUBIO. *Delta-Modulation Coding Redesign for Feedback-Controlled Systems*, in "IEEE Transactions on Industrial Electronics", 2009, vol. 56, n^o 7, p. 1-20, <http://hal.archives-ouvertes.fr/hal-00394981/en/>.
- [3] R. CARLI, G. COMO, P. FRASCA, F. GARIN. *Distributed averaging on digital erasure networks*, in "Automatica", 2010, In press (available online) [DOI : 10.1016/J.AUTOMATICA.2010.10.015], <http://hal.archives-ouvertes.fr/inria-00541039/en/>.
- [4] P. DOLCINI, C. CANUDAS DE WIT, H. BECHART. *Dry Clutch Control for Automotive Applications*, Advances in Industrial Control, Springer, Oct 2010, <http://hal.inria.fr/hal-00536612/en/>.
- [5] A. KIBANGOU, G. FAVIER. *Tensor analysis for model structure determination and parameter estimation of block-oriented nonlinear systems*, in "IEEE Journal of Selected Topics in Signal Processing", 2010, vol. Special issue on Model Order Selection in Signal Processing Systems, vol. 4, n^o 3, p. 514-525, <http://hal.inria.fr/hal-00417815/en/>.
- [6] N. MARCHAND, H. HABLY, A. CHEMORI. *Global stabilization with low computational cost of the discrete time chain of integrators by means of bounded controls*, in "IEEE Transactions on Automatic Control", 2007, vol. 52, n^o 5, p. 948-952.
- [7] Y.-J. PAN, C. CANUDAS DE WIT, O. SENNAME. *A new predictive approach for bilateral teleoperation with applications to drive-by-wire systems*, in "IEEE Transaction on Robotics", December 2006, vol. Vol. 22, n^o No. 6, p. 1146-1162.
- [8] D. ROBERT, O. SENNAME, D. SIMON. *An H_∞ LPV design for sampling varying controllers : experimentation with a T inverted pendulum*, in "IEEE Transactions on Control Systems Technology", 2010, vol. 18, n^o 3, p. 741-749, <http://hal.archives-ouvertes.fr/hal-00448496/en/>.
- [9] A. SEURET. *Stability analysis for sampled-data systems with a time-varying period*, in "48th IEEE Conference on Decision and Control, CDC 2009", China Shanghai, 2009, <http://hal.archives-ouvertes.fr/hal-00403252/en/>.
- [10] E. WITRANT, C. CANUDAS DE WIT, D. GEORGES, M. ALAMIR. *Remote Stabilization via Communication Networks with a Distributed Control Law*, in "IEEE Transactions on Automatic Control", august 2007, vol. 52, No.8, p. 1480-1486, <http://hal.archives-ouvertes.fr/hal-00201790/en/>.

Publications of the year

Doctoral Dissertations and Habilitation Theses

- [11] C. ALBEA-SANCHEZ. *Control Design for Electronic Power Converters*, Institut National Polytechnique de Grenoble - INPG and Universidad de Sevilla, September 2010, <http://hal.inria.fr/tel-00539077/en>.

Articles in International Peer-Reviewed Journal

- [12] C. ALBEA-SANCHEZ, F. GORDILLO ALVAREZ, C. CANUDAS DE WIT. *Adaptive Control Design for a Boost Inverter*, in "Control Engineering Practice", September 2010, CONPRA2586 [DOI : 10.1016/J.CONENGPRAC.2010.08.007], <http://hal.inria.fr/hal-00531760/en>.
- [13] A.-M. ALT, D. SIMON. *Control strategies for H.264 video decoding under resources constraints*, in "ACM SIGOPS Operating Systems Review", 2010, <http://hal.inria.fr/inria-00534759/en/>.
- [14] R. CARLI, G. COMO, P. FRASCA, F. GARIN. *Distributed averaging on digital erasure networks*, in "Automatica", 2010, In press [DOI : 10.1016/J.AUTOMATICA.2010.10.015], <http://hal.inria.fr/inria-00541039/en>.
- [15] J. M. GOMES DA SILVA, A. SEURET, E. FRIDMAN, J.-P. RICHARD. *Stabilization of Neutral Systems with Saturating Control Inputs*, in "International Journal of Systems Science", January 2010, 6, <http://hal.inria.fr/hal-00421351/en>.
- [16] A. KIBANGOU, G. FAVIER. *Tensor analysis for model structure determination and parameter estimation of block-oriented nonlinear systems*, in "IEEE Journal of Selected Topics in Signal Processing", 2010, vol. Special issue on Model Order Selection in Signal Processing Systems, vol. 4, n^o 3, p. 514-525, <http://hal.inria.fr/hal-00417815/en>.
- [17] L. MALRAIT, S. BOUCHENAK, N. MARCHAND. *Experience with ConSer: A System for Server Control Through Fluid Modeling*, in "IEEE Transactions on Computers", 2010, <http://hal.inria.fr/hal-00480859/en>.
- [18] D. ROBERT, O. SENAME, D. SIMON. *An Hinf LPV design for sampling varying controllers : experimentation with a T inverted pendulum*, in "IEEE Transactions on Control Systems Technology", May 2010, vol. 18, n^o 3, p. 741-749 [DOI : 10.1109/TCST.2009.2026179], <http://hal.inria.fr/hal-00448496/en>.
- [19] D. SIMON, M. E. M. BEN GAÏD. *Discussion on: "A Control Based Solution for Integrated Dynamic Capacity Assignment, Congestion Control and Scheduling in Wireless Networks"*, in "European Journal of Control", 2010, vol. 16, n^o 2, p. 185-186, <http://hal.inria.fr/inria-00482551/en/>.

International Peer-Reviewed Conference/Proceedings

- [20] A.-M. ALT, D. SIMON. *Control strategies for H.264 video decoding under resources constraints*, in "Fifth International Workshop on Feedback Control Implementation and Design in Computing Systems and Networks (FeBID 2010)", Paris, France, April 2010, to appear in "Operating Systems Review", <http://hal.inria.fr/inria-00482576/en>.
- [21] R. BARRETO-JIJON, C. CANUDAS DE WIT, S.-I. NICULESCU, J. DUMON. *Adaptive Observer Design under Low Data Rate Transmission with Applications to Oil Well Drill-string*, in "American Control Con-

- ference 2010", États-Unis Baltimore, Maryland, USA, June 2010, http://hal.inria.fr/docs/00/43/91/73/PDF/Observer_Drilling_V3.pdf.
- [22] L. BRIÑÓN ARRANZ, A. SEURET, C. CANUDAS DE WIT. *Contraction Control of a Fleet Circular Formation of AUVs under Finite Communication Range*, in "2010 American Control Conference", États-Unis Baltimore, June 2010, 6, <http://hal.inria.fr/hal-00448036/en>.
- [23] L. BRIÑÓN ARRANZ, A. SEURET, C. CANUDAS DE WIT. *General Framework using Affine Transformations to Formation Control Design*, in "2nd IFAC Workshop on Distributed Estimation and Control in Networked Systems", France Annecy, September 2010, 6, <http://hal.inria.fr/hal-00506562/en>.
- [24] N. CARDOSO DE CASTRO, C. CANUDAS DE WIT, K. H. JOHANSSON. *On Energy-Aware Communication and Control Co-design in Wireless Networked Control Systems*, in "2nd IFAC Workshop on Distributed Estimation and Control in Networked Systems (NecSys'10)", France Annecy, September 2010, p. 49-54, <http://hal.inria.fr/hal-00536072/en>.
- [25] R. CECCARELLI, P. MOULIN, C. CANUDAS DE WIT. *Turbine Efficiency Estimation for Fault Detection Application*, in "SAE 2010 World Congress & Exhibition", États-Unis Detroit, SAE International, April 2010, vol. <http://papers.sae.org/2010-01-0568/> [DOI : 10.4271/2010-01-0568], <http://hal.inria.fr/hal-00536623/en>.
- [26] A. L. DO, O. SENAME, L. DUGARD, S. AUBOUET, R. RAMIREZ-MENDOZA. *An LPV Approach for Semi-Active Suspension Control*, in "11th Pan-American Congress of Applied Mechanics - PACAM XI", Brésil Foz do Iguaçú, Paraná, January 2010, PAC0546, <http://hal.inria.fr/hal-00496934/en>.
- [27] W. JIANG, A. KRUSZEWSKI, E. FRIDMAN, J.-P. RICHARD. *Delay dependent stability analysis of interval time-delay systems*, in "TDS'10, 9th IFAC Workshop on Time Delay Systems", Tchèque, République Prague, 2010, <http://hal.inria.fr/hal-00519491/en>.
- [28] W. JIANG, A. SEURET. *Improved stability analysis of networked control systems under asynchronous sampling and input delay*, in "2nd IFAC Workshop on Distributed Control and Estimation of Networked Systems", France Annecy, September 2010, 073, <http://hal.inria.fr/hal-00515425/en>.
- [29] A. KIBANGOU. *Blind receivers for MISO Communication systems using a Nonlinear Precoder*, in "European Signal Processing Conference (EUSIPCO 2010)", Danemark Aalborg, August 2010, <http://hal.inria.fr/hal-00491944/en>.
- [30] A. KIBANGOU. *Distributed Estimation over Unknown Fading Channels*, in "2nd IFAC Workshop on Distributed Estimation and Control in Networked Systems (NecSys)", Annecy, France, September 2010, <http://hal.inria.fr/hal-00540821/en>.
- [31] A. KIBANGOU, L. ROS, C. SICLET. *Doppler Estimation and Data detection for Underwater Acoustic ZF-OFDM Receiver*, in "IEEE International Symposium on Wireless Communication Systems", Royaume-Uni York, September 2010, <http://hal.inria.fr/hal-00498161/en>.
- [32] A. KIBANGOU, L. ROS, C. SICLET. *Joint channel and doppler estimation for multicarrier underwater communications*, in "Int. Conf. on Acoustics, Speech, and Signal Processing (ICASSP)", États-Unis Dallas, March 2010, <http://hal.inria.fr/hal-00443946/en>.

- [33] A. KIBANGOU, C. SICLET, L. ROS. *ZF OFDM Receiver for Underwater Communications*, in "Int. Symp. on Communications, Control, and Signal Processing (ISCCSP 2010)", Chypre Lemesos, March 2010, <http://hal.inria.fr/hal-00449421/en>.
- [34] A. KIBANGOU, A. L. F. DE ALMEIDA. *Distributed PARAFAC based DS-CDMA blind receiver for wireless sensor networks*, in "IEEE International Workshop on Signal Processing Advances in Wireless Communications (SPAWC)", Maroc Marrakech, June 2010, <http://hal.inria.fr/hal-00480584/en>.
- [35] E. LOVISARI, F. GARIN, S. ZAMPIERI. *A resistance-based approach to consensus algorithm performance analysis*, in "49th IEEE Conference on Decision and Control (CDC 2010)", Atlanta (Georgia, USA), 2010, p. 5714-5719, <http://hal.inria.fr/inria-00534493/en>.
- [36] E. LOVISARI, F. GARIN, S. ZAMPIERI. *A resistance-based approach to performance analysis of the consensus algorithm*, in "19th International Symposium on Mathematical Theory of Networks and Systems (MTNS 2010)", Hongrie Budapest, 2010, <http://hal.inria.fr/inria-00534491/en>.
- [37] B. MOORE, C. CANUDAS DE WIT. *Source Seeking via Collaborative Measurements by a Circular Formation of Agents*, in "IEEE American Control Conference", États-Unis Baltimore, Maryland, July 2010, <http://hal.inria.fr/hal-00536595/en>.
- [38] É. ROCHE, O. SENAME, D. SIMON. *LFT/Hinf varying sampling control for Autonomous Underwater Vehicles*, in "4th IFAC Symposium on System, Structure and Control", Italie Ancona, IFAC, 2010, <http://hal.inria.fr/inria-00497049/en/>.
- [39] G. RODRIGUES DE CAMPOS, A. SEURET. *Continuous-time double integrator consensus algorithms improved by an appropriate sampling*, in "2nd IFAC Workshop on Distributed Control and Estimation of Networked Systems", France Annecy, September 2010, 017, <http://hal.inria.fr/hal-00515427/en>.
- [40] A. SEURET. *Exponential stability and stabilization of sampled-data systems with time-varying period*, in "9th IFAC Workshop on Time Delay Systems", Tchèque, République Praha, June 2010, <http://hal.inria.fr/hal-00458829/en>.
- [41] H. ZAKARIA, S. DURAND, N. MARCHAND, L. FESQUET. *Integrated Asynchronous Regulation for Nanometric Technologies*, in "1st IEEE European workshop on CMOS Variability (VARI'10)", France Montpellier, IEEE Computer Society, 2010, p. 86-91, <http://hal.inria.fr/hal-00492946/en>.

National Peer-Reviewed Conference/Proceedings

- [42] S. ARIAS, F. BOUDIN, R. PISSARD-GIBOLLET, D. SIMON. *ORCCAD, robot controller model and its support using Eclipse Modeling tools*, in "5th National Conference on "Control Architecture of Robots"", Douai, France, 2010, <http://hal.inria.fr/inria-00482559/en/>.

Scientific Books (or Scientific Book chapters)

- [43] C. AUBRUN, D. SIMON, Y.-Q. SONG. *Introduction and problem statement*, in "Co-design approaches for dependable networked control systems", C. AUBRUN, D. SIMON, Y.-Q. SONG (editors), Wiley / Engineering & Materials Science / Electrical & Electronics Engineering / Control Systems Technology, ISTE Wiley, April 2010, <http://hal.inria.fr/inria-00447362/en>.

- [44] C. AUBRUN, D. SIMON, Y.-Q. SONG. *Preliminary notions and state of the art*, in "Co-design Approaches for Dependable Networked Control Systems", C. AUBRUN, D. SIMON, Y.-Q. SONG (editors), ISTE Wiley, 2010, p. 19-53, <http://hal.archives-ouvertes.fr/hal-00456249/en/>.
- [45] M. E. M. BEN GAÏD, D. ROBERT, O. SENAME, A. SEURET, D. SIMON. *Computing aware control*, in "Co-design approaches for dependable networked control systems", C. AUBRUN, D. SIMON, Y.-Q. SONG (editors), Wiley / Engineering & Materials Science / Electrical & Electronics Engineering / Control Systems Technology, ISTE Wiley, April 2010, <http://hal.inria.fr/inria-00447368/en>.
- [46] M. E. M. BEN GAÏD, D. ROBERT, O. SENAME, D. SIMON. *Plant state based feedback scheduling*, in "Co-design approaches for dependable networked control systems", C. AUBRUN, D. SIMON, Y.-Q. SONG (editors), Wiley / Engineering & Materials Science / Electrical & Electronics Engineering / Control Systems Technology, ISTE Wiley, April 2010, <http://hal.inria.fr/inria-00447371/en>.
- [47] C. BERBRA, S. GENTIL, S. LESECQ, D. SIMON. *Control and Diagnosis for an Unmanned Aerial Vehicle*, in "Co-design approaches for dependable networked control systems", ISTE Wiley, January 2010, 340 p., <http://hal.inria.fr/hal-00423869/en>.
- [48] C. BERBRA, S. GENTIL, S. LESECQ, D. SIMON. *Control and Diagnosis for an Unmanned Aerial Vehicle*, in "Co-design approaches for dependable networked control systems", Wiley, 2010, 340 p., <http://hal.archives-ouvertes.fr/hal-00423869/en/>.
- [49] P. DOLCINI, C. CANUDAS DE WIT, H. BECHART. *Dry Clutch Control for Automotive Applications*, Advances in Industrial Control, Springer, October 2010, <http://hal.inria.fr/hal-00536612/en>.

Books or Proceedings Editing

- [50] C. AUBRUN, D. SIMON, Y.-Q. SONG. , C. AUBRUN, D. SIMON, Y.-Q. SONG (editors) *Co-design Approaches for Dependable Networked Control Systems*, ISTE Wiley, January 2010, <http://hal.inria.fr/inria-00443847/en>.

Research Reports

- [51] A. S. ABOUBEKR, G. DELAVAL, R. PISSARD-GIBOLLET, É. RUTTEN, D. SIMON. *Automatic generation of discrete handlers of real-time continuous control tasks*, INRIA, July 2010, n^o RR-7332, <http://hal.inria.fr/inria-00498394/en>.
- [52] A. FARHADI, C. CANUDAS DE WIT. *Multi-level classification and formulation of an integration framework for estimation/communication/computation (EC2) co-design*, INRIA, GIPSA-lab, July 2010, <http://hal.inria.fr/hal-00536613/en>.
- [53] J. JIMENEZ, M. LOPEZ, P. SMYTH, G. GENNARI, D. RAIMONDO, P. DONAGGIO, S. GASPARELLA, B. LAIN, J. OPDERBECKE, L. SCHENATO, D. SIMON, T. OECHTERING, C. FISCHIONE. *FeedNetBack-D01.04 - Tool Specifications*, INRIA, July 2010, <http://hal.inria.fr/inria-00536949/en>.
- [54] J. OPDERBECKE, A. KIBANGOU. *FeedNetBack-D08.02- Tools for underwater fleet communication*, INRIA, IFREMER, 2010, <http://hal.archives-ouvertes.fr/hal-00546677/en/>.
- [55] É. ROCHE, O. SENAME, A. SEURET, D. SIMON, S. VARRIER. *FeedNetBack-D04.03 - Design of Robust Variable Rate Controllers*, INRIA, GIPSA-lab, July 2010, <http://hal.inria.fr/inria-00536601/en>.

Other Publications

- [56] D. STEFAN. *Analyse des lois de commande pour le trafic routier*, Master Automatique, Grenoble INP, 2010.
- [57] F. STEVENIN. *Modelisation of the South Ring of Grenoble by a microscopic simulator*, Master Automatique, Grenoble INP, 2010.
- [58] J. TORDESILLAS ILLAN. *Electric power steering system adapted for people with reduced mobility*, Master Automatique, Grenoble INP, 2010.
- [59] S. VARRIER. *Robust control of autonomous underwater vehicles*, Master Automatique, Grenoble INP, 2010.

References in notes

- [60] P. J. ANDRIANAINA, D. SIMON, J.-M. CRAYSSAC, J.-C. LAPERCHE. *Beyond WCET-based Design for Real-time Avionics Control Systems*, in "IFAC World Congress", 2011, submitted.
- [61] J.-J. BORRELLY, E. COSTE MANIÈRE, B. ESPIAU, K. KAPELLOS, R. PISSARD-GIBOLLET, D. SIMON, N. TURRO. *The Orccad Architecture*, in "International Journal on Robotic Research", 1998, vol. 17, n^o 4, p. 338–359.
- [62] L. BRIÑÓN ARRANZ, A. SEURET, C. CANUDAS DE WIT. *Translation Control of a Fleet Circular Formation of AUVs under Finite Communication Range*, in "48th IEEE Conference on Decision and Control, CDC 2009", Chine Shanghai, 2009, <http://hal.archives-ouvertes.fr/hal-00403253/en/>.
- [63] C. CANUDAS DE WIT, J. JAGLIN. *Energy-aware and entropy coding for Networked Controlled Linear Systems*, in "International Journal of Robust and Nonlinear Control", 2009, vol. 19, n^o 16, p. 1851–1870, <http://hal.archives-ouvertes.fr/hal-00344234/en/>.
- [64] R. CECCARELLI, C. CANUDAS DE WIT, P. MOULIN, A. SCIARRETTA. *Model-based Adaptive Observers for Intake Leakage Detection in Diesel Engines*, in "American Control Conference, IEEE ACC'09", Saint Louis, Missouri, USA, 2009, <http://hal.archives-ouvertes.fr/hal-00394982/en/>.
- [65] R. CECCARELLI, P. MOULIN, C. CANUDAS DE WIT. *Robust Strategy for Intake Leakage Detection in Diesel Engines*, in "Proc. of IEEE Application Control Conference, MSC", Russie Saint Petersburg, 2009, <http://hal.archives-ouvertes.fr/hal-00394983/en/>.
- [66] R. CECCARELLI, P. MOULIN, C. CANUDAS DE WIT. *Turbine Efficiency Estimation for Fault Detection Application*, in "SAE Technical Paper Series", 2010, submitted.
- [67] A. CERVIN, J. EKER, B. BERNHARDSSON, K.-E. ÅRZÉN. *Feedback-Feedforward Scheduling of Control Tasks*, in "Real Time Systems", 2002, vol. 23, n^o 1, p. 25–54.
- [68] G. COMO, F. FAGNANI, S. ZAMPIERI. *Anytime reliable transmission of continuous information through digital noisy channels*, in "Siam Journal on Control and Optimization", 2010, vol. 48, n^o 6, p. 3903–3924.
- [69] P. DOYLE, J. SNELL. *Random Walks and Electric Networks*, Carus Monographs, Mathematical Association of America, 1984.

- [70] S. DURAND, N. MARCHAND. *An Event-Based PID Controller With Low Computational Cost*, in "8th International Conference on Sampling Theory and Applications", France Marseille, 2009, <http://hal.archives-ouvertes.fr/hal-00393031/en/>.
- [71] S. DURAND, N. MARCHAND. *Dispositif de commande d'alimentation d'un ordinateur*, 2009, n^o 09/001576, Patent, <http://hal.archives-ouvertes.fr/hal-00404397/en/>.
- [72] S. DURAND, N. MARCHAND. *Dynamic Voltage and Frequency Scaling of Multicore System with Energy-Performance Tradeoff*, in "48th IEEE Conference on Decision and Control, CDC 2009", Chine Shanghai, 2009, <http://hal.archives-ouvertes.fr/hal-00404053/en/>.
- [73] S. DURAND, N. MARCHAND. *Fast Predictive Control of Micro Controller's Energy-Performance Tradeoff*, in "3rd IEEE Multi-conference on Systems and Control, 18th IEEE International Conference on Control Applications", Russie Saint Petersburg, 2009, <http://hal.archives-ouvertes.fr/hal-00391988/en/>.
- [74] S. DURAND, N. MARCHAND. *Further Results on Event-Based PID Controller*, in "European Control Conference, ECC'09", Hongrie Budapest, 2009, <http://hal.archives-ouvertes.fr/hal-00368535/en/>.
- [75] S. DURAND, N. MARCHAND. *Dispositif de commande d'alimentation d'un ordinateur*, 2009, n^o 09/004686, Patent, <http://hal.archives-ouvertes.fr/hal-00439352/en/>.
- [76] F. GARIN, L. SCHENATO. *A Survey on Distributed Estimation and Control Applications Using Linear Consensus Algorithms*, in "Networked Control Systems", A. BEMPORAD, M. HEEMELS, M. JOHANSSON (editors), Lecture Notes in Control and Information Sciences, Springer, 2011, vol. 406, p. 75-107 [DOI : 10.1007/978-0-85729-033-5_3], <http://hal.inria.fr/inria-00541057/en/>.
- [77] J. JAGLIN, C. CANUDAS DE WIT, A. FARHADI. *Dwelltime adaptive delta modulation signal coding for networked controlled systems*, in "IEEE Transactions on Automatic Control", 2010, submitted.
- [78] N. JIA, Y.-Q. SONG, F. SIMONOT-LION. *Graceful degradation of the quality of control through data drop policy*, in "European Control Conference, ECC", Kos, Greece, 2007.
- [79] KARL HENRIK. JOHANSSON, M. TÖRNGREN, L. NIELSEN. *Vehicle applications of controller area network*, Handbook of Networked and Embedded Control Systems, Birkhauser, 2005.
- [80] A. KIBANGOU, G. FAVIER. *Blind Equalization of Nonlinear Channels using Tensor decompositions with code/space/time diversities*, in "Signal Processing", February 2009, vol. 89, n^o 2, p. 133–143.
- [81] A. KIBANGOU, G. FAVIER. *Non-iterative solution for PARAFAC with a Toeplitz matrix factor*, in "Proc. EUSIPCO", Glasgow, Scotland, August 24-28 2009.
- [82] B.-C. KIM, I.-T. LU. *Parameter study of OFDM underwater communications system*, in "Proc. of OCEANS 2000 MTS/IEEE Conference and Exhibition", September 11-14 2000, vol. 2, p. 1251–1255.
- [83] H. KWON, J. CIOFFI. *Multi-User MISO Broadcast Channel with User-Cooperating Decoder*, in "Proc. of the IEEE 68 th Vehicular Technology Conference (VTC-Fall)", Calgary, Canada, September 2008, p. 1–5.

- [84] B. LI, S. ZHOU, M. STOJANOVIC, L. FREITAG, P. WILLETT. *Multicarrier communication over underwater acoustic channels with nonuniform Doppler shifts*, in "IEEE Journal of Oceanic Engineering", 2008, vol. 33, n^o 2, p. 198–209.
- [85] N. MARCHAND. *Stabilization of Lebesgues sampled systems with bounded controls: the chain of integrators case*, in "IFAC World Congress", 2008.
- [86] B. MOORE, C. CANUDAS DE WIT. *Formation Control via Distributed Optimization of Alignment Error*, in "48th IEEE Conference on Decision and Control, CDC 2009", Chine Shanghai, 2009, p. 3075 - 3080, <http://hal.archives-ouvertes.fr/hal-00404480/en/>.
- [87] D. NION, L. DE LATHAUWER. *An Enhanced Line Search Scheme for Complex-Valued Tensor Decompositions. Application in DS-CDMA*, in "Signal Processing", March 2008, vol. 88, n^o 3, p. 749–755.
- [88] R. OLFATI-SABER, A. FAX, R. MURRAY. *Consensus and cooperation in networked multi-agent systems*, in "Proceedings of the IEEE", 2007, vol. 95, n^o 1, p. 215-233.
- [89] É. ROCHE, O. SENAME, D. SIMON, S. VARRIER. *A hierarchical Varying Sampling H_∞ Control of an AUV*, in "IFAC World Congress", 2011, submitted.
- [90] H. SENOL, C. TEPEDELENLIOGLU. *Performance of distributed estimation over unknown parallel fading channels*, in "IEEE Trans. on Signal Proc.", December 2008, vol. 56, n^o 12, p. 6057–6068.
- [91] A. SEURET, D. V. DIMAROGONAS, K. H. JOHANSSON. *Consensus of double integrator multi-agents under communication delay*, in "8th IFAC Workshop on Time Delay Systems", Roumanie Sinaia, 2009, <http://hal.archives-ouvertes.fr/hal-00391651/en/>.
- [92] A. SEURET, C. EDWARDS, S. SPURGEON, E. FRIDMAN. *Static output feedback sliding mode control design via an artificial stabilizing delay*, in "IEEE Transactions on Automatic Control", 2009, vol. 54, n^o 2, p. 256 - 265, <http://hal.archives-ouvertes.fr/hal-00385893/en/>.
- [93] A. SEURET, K. H. JOHANSSON. *Networked control under time-synchronization errors*, in "8th IFAC Workshop on Time Delay systems", Roumanie Sinaia, 2009, <http://hal.archives-ouvertes.fr/hal-00391611/en/>.
- [94] A. SEURET, K. H. JOHANSSON. *Stabilization of time-delay systems through linear differential equations using a descriptor representation*, in "European Control Conference, ECC'09", Hungary Budapest, 2009, <http://hal.inria.fr/inria-00391311/en/>.
- [95] A. SEURET, J.-P. RICHARD. *Convergence rate of a networked control systems with time-varying delays and packet dropout*, in "provisionnaly accepted in IEEE Tans. on Automatic Control", 2008.
- [96] A. SEURET. *Networked control under synchronization errors*, in "ACC'08, Seattle, USA", June 2008.
- [97] A. SEURET. *Lyapunov-Krasovskii Functionals Parameterized with Polynomials*, in "ROCOND'09", Israël Haifa, 2009, <http://hal.archives-ouvertes.fr/hal-00386275/en/>.

- [98] A. SEURET. *Stability analysis for sampled-data systems with a time-varying period*, in "48th IEEE Conference on Decision and Control, CDC 2009", China Shanghai, 2009, 6, <http://hal.archives-ouvertes.fr/hal-00403252/en/>.
- [99] A. SEURET, D. V. DIMAROGONAS, K. H. JOHANSSON. *Consensus under communication delays*, in "Proceedings of the 47th IEEE Conference on Decision and Control, CDC 2008", Cancun Mexique, December 2008, <http://hal.archives-ouvertes.fr/hal-00386104/en/>.
- [100] N. SIDIROPOULOS, R. BUDAMPATI. *Khatri-Rao space-time codes*, in "IEEE Trans. on Signal Processing", Oct. 2002, vol. 50, n^o 10, p. 2396-2407.
- [101] N. SIDIROPOULOS, G. GIANNAKIS, R. BRO. *Blind PARAFAC receivers for DS-CDMA systems*, in "IEEE Trans. on Signal Processing", March 2000, vol. 48, n^o 3, p. 810–823.
- [102] D. SIMON, D. ROBERT, O. SENAME. *Robust control/scheduling co-design: application to robot control*, in "RTAS'05 IEEE Real-Time and Embedded Technology and Applications Symposium", San Francisco, march 2005.
- [103] D. SIMON, O. SENAME, D. ROBERT. *Conception conjointe commande/ordonnancement et ordonnancement régulé*, in "Systèmes Temps Réel Tome II : Ordonnancement, Réseaux, Qualité de Service", Hermes, 2006, vol. 2.
- [104] M. STOJANOVIC. *Underwater acoustic communication channels: Propagation models and statistical characterization*, in "IEEE Communications Mag.", January 2009, vol. 47, n^o 1, p. 84–89.
- [105] S. TATIKONDA, S. K. MITTER. *Control under communications constraints*, in "IEEE Transaction on Automatic Control", July 2004, vol. 49, n^o 7, p. 1056–1068.
- [106] M. TÖRNGREN, D. HENRIKSSON, O. REDELL, C. KIRSCH, J. EL-KHOURY, D. SIMON, Y. SOREL, H. ZDENEK, K.-E. ÅRZÉN. *Co-design of Control Systems and their real-time implementation - A Tool Survey*, Royal Institute of Technology, KTH, Stockholm, 2006, n^o TRITA - MMK 2006:11.
- [107] Z. WANG, G. GIANNAKIS. *Wireless multicarrier communications: Where Fourier meets Shannon*, in "IEEE Signal Processing Magazine", 2000, vol. 17, n^o 3, p. 29–48.
- [108] T. WIMALAJEewa, S. JAYAWEEERA. *Power efficient distributed estimation in a bandlimited Wireless sensor network*, in "Proc. of 41st Asilomar Conf. on Signals, Systems and Computers", Pacific Grove, CA, USA, November 2007, p. 2156–2160.
- [109] E. WITRANT, D. GEORGES, C. CANUDAS DE WIT, O. SENAME. *Stabilisation des systèmes commandés par réseau: une approche prédictive*, in "Systèmes commandés en réseaux", JEAN-PIERRE. RICHARD, T. DIVOUX (editors), Traité IC2, Lavoisier - Hermès, 2007, p. 83-124, <http://hal.archives-ouvertes.fr/hal-00176046/en/>.
- [110] A. L. F. DE ALMEIDA, G. FAVIER, J.-C.-M. MOTA. *PARAFAC-based unified tensor modeling for wireless communication systems with application to blind multiuser equalization*, in "Signal Processing", February 2007, vol. 87, n^o 2, p. 337-351.

- [111] K.-E. ÅRZÉN. *A Simple Event-Based PID Controller*, in "Preprints 14th World Congress of IFAC", Beijing, P.R. China, January 1999.