



IN PARTNERSHIP WITH:
CNRS

**Institut polytechnique de
Grenoble**

**Université Pierre Mendès-France
(Grenoble 2)**

**Université Joseph Fourier
(Grenoble 1)**

Activity Report 2011

Project-Team E-MOTION

Geometry and Probability for Motion and Action

IN COLLABORATION WITH: Laboratoire d'Informatique de Grenoble (LIG)

RESEARCH CENTER
Grenoble - Rhône-Alpes

THEME
Robotics

Table of contents

1. Members	1
2. Overall Objectives	1
2.1. Introduction	1
2.2. Highlights of the Year	2
3. Application Domains	3
3.1. Introduction	3
3.2. Future cars and transportation systems	3
3.3. Service, intervention, and human assistance robotics	3
3.4. Potential spin-offs in some other application domains	3
4. Software	3
4.1. PROTEUS	3
4.2. AROSDYN	4
4.3. Bayesian Occupancy Filter	5
4.4. PROBT	8
5. New Results	8
5.1. Dynamic World Perception and Evolution Prediction	8
5.1.1. Environment modeling and sensor data acquisition	8
5.1.2. Bayesian fusion of visual and telemetric information	10
5.1.2.1. Concept of BOF and obstacle detection in occupancy grids	10
5.1.2.2. Disparity space approach for a vision based occupancy grid	10
5.1.2.3. Processing of multi-layer telemetric data in probabilistic framework	12
5.1.3. Sensor Fusion and parameters estimation	12
5.1.4. Analysis of dynamic scenes for collision risk assessment	15
5.1.5. Recognition for intelligent vehicles	15
5.1.6. Context-aware Bayesian estimation of risk at road intersections for cooperative vehicles	15
5.2. Human Centered Navigation in the physical world	18
5.2.1. Goal oriented risk based navigation in dynamic uncertain environment	18
5.2.2. Social conventions based navigation	19
5.2.3. Autonomous Wheelchair for the Elderly People's Assistance	21
5.2.4. Multi-Robot Distributed Control under Environmental Constraints	22
5.2.5. Exploring stochastic optimization method to navigate between humans	25
5.3. Bayesian Modelling of Sensorimotor Systems and Behaviors	26
5.3.1. Bayesian programming applied to a multi-player video games	26
5.3.2. Bayesian modelling to implement and compare different theories of speech communication	28
6. Contracts and Grants with Industry	28
6.1.1. Toyota Motors Europe	28
6.1.2. Renault	28
6.1.3. GRAAL	29
6.1.4. PROTEUS	29
7. Partnerships and Cooperations	29
7.1. National Initiatives	29
7.1.1. ADT ArosDyn	29
7.1.2. AEN PAL	30
7.2. European Initiatives	30
7.2.1. Collaborations in European Programs	30
7.2.1.1. BACS project	30
7.2.1.2. Intersafe 2 project	31
7.2.1.3. sFly project	31

7.2.1.4. HAVEit project	31
7.2.2. Major European Organizations with which you have followed Collaborations	32
7.3. International Initiatives	32
7.3.1. “ict-PAMM”	32
7.3.2. “Predimap”	32
7.3.3. “PRETIV”	32
7.3.4. Visits of International Scientists	33
7.3.5. Participation In International Programs	33
8. Dissemination	33
8.1. Animation of the scientific community	33
8.2. Teaching	33
9. Bibliography	34

Project-Team E-MOTION

Keywords: Robotics, Risk Analysis, Human Assistance, Perception, Robot Motion

Beginning of the Team: 01/02/2004.

1. Members

Research Scientists

Christian Laugier [Team Leader, Research Director (DR) Inria, HdR]

Agostino Martinelli [Research Associate (CR) INRIA]

Emmanuel Mazer [Research Director (DR) CNRS, HdR]

Faculty Member

Anne Spalanzani [Université Pierre-Mendès-France, Grenoble. Associate Professor]

External Collaborators

Pierre Bessière [LPPA lab]

Kamel Mekhnacha [CTO at Probayes]

Christopher Tay [Engineer at Probayes]

Alejandro Dizan Vasquez Govea [Instituto Tecnológico y de Estudios Superiores de Monterrey (Mexico)]

Engineers

Amaury Nègre [Research Engineer (IR) CNRS]

Igor Paromtchik [ADT ArosDyn INRIA, Principal Engineer]

Juan Lahera-Perez [Expert Engineer (ANR Proteus)]

Mathias Perrollaz [Expert Engineer (Toyota contract)]

PhD Students

Alessandro Renzaglia [Sfly project fellowship]

Jorge Rios-Martinez [Conacyt fellowship + INRIA]

Arturo Escobedo-Cabello [INRIA fellowship]

Raphael Laurent [French Minister fellowship]

Stéphanie Lefèvre [Renault Cifre fellowship]

Gabriel Synnaeve [French Minister fellowship]

Chiara Troiani [Sfly project fellowship]

Procopio Stein [INRIA fellowship for internship]

Post-Doctoral Fellow

Alexandros Makris [INRIA fellowship]

Administrative Assistant

Myriam Etienne [Secretary (SAR) Inria]

2. Overall Objectives

2.1. Introduction

Main challenge: The overall objective of the Team-Project *e-Motion* is to address some fundamental and open issues located at the heart of the emerging research field called “Human Centered Robotics”. More precisely, our goal is to develop *Perception, Decision, and Control* algorithmic models whose characteristics fit well with the constraints of human environments; then, these models have to be embedded into “*artificial systems*” having the capability to evolve safely in human environments while having various types of interactions with human beings. Such systems have to exhibit sufficiently efficient and robust behaviors for being able to operate in *open and dynamic environments*, i.e. in partially known environments, where time, dynamics

and interactions play a major role. Recent technological progress on embedded computational power, on sensor technologies, and on miniaturized mechatronic systems, make the required technological breakthroughs potentially possible (including from the scalability point of view).

Approach and research themes: Our approach for addressing the previous challenge is to combine the respective advantages of the *Computational Geometry* and of the *Theory of Probabilities*, while working in cooperation with neurophysiologists for the purpose of taking into account Human perception and navigation models. Two main research themes are addressed under both the algorithmic and human point of views; these research themes are respectively related to the problems of *understanding dynamic scenes in human environments* and of *navigating interactively and safely in such environments*.

- *Perception & Situation awareness in Human environments.* The main problem is to understand complex dynamic scenes involving human beings, by exploiting prior knowledge and a flow of perceptive data coming from various sensors. Our approach for solving this problem is to develop three complementary paradigms:
 - *Bayesian Perception:* How to take into account prior knowledge and uncertain sensory data in a dynamic context ?
 - *Risk Assessment:* How to evaluate this collision risk (i.e. potential future collisions) from an estimate of the current state of the dynamic scene, and from the prediction of the future behaviors of the scene participants ?
 - *Behavior modeling & Learning:* How to model and to learn behaviors from observations ?
- *Navigation, Control, and Interaction in Human environments.* The main problem is to take safe and socially acceptable goal-oriented navigation and control decisions, by using prior knowledge about the dynamic scenario and the related social rules, and by fusing noisy sensory data in order to estimate the state parameters. Our approach for addressing this problem is to develop two complementary concepts:
 - *Human-Aware Navigation:* How to navigate safely towards a given goal in a dynamic environment populated by human beings, while taking into account human-robot interactions and while respecting social rules and human comfort ?
 - *State Estimation & Control:* How to estimate the state parameters from noisy and sometime missing sensory data ? How to control a robot or a fleet of robots for executing a task in a near optimal way ?

2.2. Highlights of the Year

- Renewing of the long-term agreement with Toyota (4 years) for common R&D studies in the field of Advanced Driver Assistance Systems. In the scope of this agreement, Toyota has lend an experimental equiped Lexus vehicle. A new PhD thesis focusing on this topic was launched.
- C. Laugier is in charge, since january 2010, of the scientific relations with Asia-Oceania at the INRIA office of International Relations. He is also member of the several commitees at the French Ministry of Research (MESR) and at the French Ministry of Foreign Affairs (MAEE).
- A patent with Toyota signed in 2010 was extended to the USA.
- C. Laugier has given an invited talk at the conference IV'11 and a workshop at IROS'11.
- Several Contracts were accepted : ict-asia PAMM, ict-asia PREDIMAP, ANR Blanc International...
- C. Laugier was Editor at IEEE ICRA conference Editorial Board (CEB).
- C. Laugier was co-chair for workshop and tutorial at the IEEE/RSJ IROS 2011 conference in San Francisco.
- C. Laugier will be program co-chair for the IEEE/RSJ IROS 2012 conference.

3. Application Domains

3.1. Introduction

The main applications of our research are those aiming at introducing advanced and secured robotized systems into human environments. In this context, we are focusing onto the following application domains: Future cars and transportation systems, Service and Human assistance robotics, and Potential spin-offs in some other application domains.

3.2. Future cars and transportation systems

Thanks to the introduction of new sensor and ICT technologies in cars and in mass transportation systems, and also to the pressure of economical and security requirements of our modern society, this application domain is quickly changing. Various technologies are currently developed by both research and industrial laboratories. These technologies are progressively arriving at maturity, as it is witnessed by the results of large scale experiments and challenges (e.g. Darpa Urban Challenge 2007) and by the fast development of ambitious projects such as the Google's car project. Moreover, the legal issue starts to be addressed (see for instance the recent law in Nevada authorizing autonomous vehicles on roads).

In this context, we are interested in the development of *ADAS*¹ systems aimed at improving comfort and safety of the cars users (e.g. ACC, emergency braking, danger warnings ...), and of *Fully Autonomous Driving* functions for controlling the displacements of private or public vehicles in some particular driving situations and/or in some equipped areas (e.g. automated car parks or captive fleets in downtown centers or private sites).

3.3. Service, intervention, and human assistance robotics

This application domain is currently quickly emerging, and more and more industrial companies (e.g. IS-Robotics, Samsung, LG ...) are now commercializing service and intervention robotics products such as vacuum cleaner robots, drones for civil or military applications, entertainment robots ...). One of the main challenges is to propose robots which are sufficiently robust and autonomous, easily usable by non-specialists, and marked at a reasonable cost. A more recent challenge for the coming decade is to develop robotized systems for assisting elderly and/or disabled people. We are strongly involved in the development of such technologies, which are clearly tightly connected to our research work on robots in human environments.

3.4. Potential spin-offs in some other application domains

Our *Bayesian Programming* tools (including the functions for decision making under uncertainty) are also impacting a large spectrum of application domains such as autonomous systems, surveillance systems, preventive maintenance for large industrial plants, fraud detection, video games, etc. These application domains are covered by our start-up *Probayes*.

4. Software

4.1. PROTEUS

Participants: Amaury Nègre, Juan Lahera-Perez.

This toolkit offers a automatic mobile robot driver, some sensors drivers (sensors as Sick laser, GPS, motion tracker, mono or stereo camera), and a 3D Simulator.

¹Advanced Driver Assistance Systems

The latest developments have been focuses on the robotics simulator. This simulator is based on the simulation and 3D rendering engine “mgEngine“ (<http://mgengine.sourceforge.net/>) embedded with the physics engine “bullets physics” (<http://bulletphysics.org>) for realistic robot dynamic simulation. We also worked on the interface with the robotics middleware “ROS“ (<http://www.ros.org>) in order to offer interoperability with many robotics applications. This software is developed in C++ and the simulator operates with the Lua scripting language.

The simulation software is used in the ANR Proteus (<http://www.anr-proteus.fr>), as a simulation engine for the PROTEUS Toolkit.

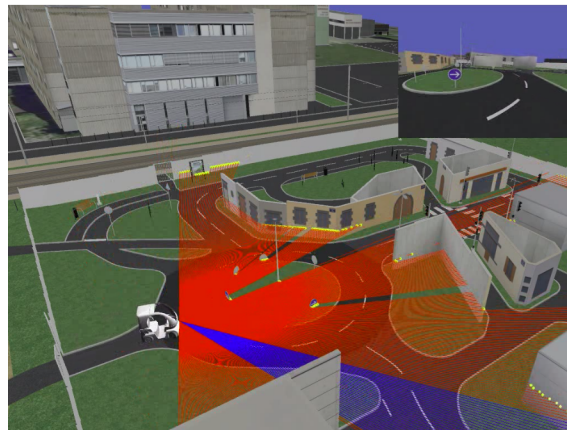

Figure 1. Screenshot of the Mobile Robot Simulator. Simulation of a Cycab robot in the “Pavin“ environment provided by the LASMEA.

- Version: 2.0
- APP:IDDN.FR.001.510040.000.S.P.2005.000.10000
- Programming language: C/C++, Lua

4.2. AROSDYN

Participants: Igor Paromtchik, Mathias Perrollaz, Alexandros Makris, Amaury Nègre, Christian Laugier.

ArosDyn (<http://arosdyn.gforge.inria.fr/>) is a system which integrates our recently developed techniques to provide a real-time collision risk estimation in a dynamic environment. The main features of this software are:

1. The deliberated design provides high maintainability, scalability and reuseness of the models and algorithms.
2. The software has a user interface (UI) which is user-friendly.
3. The software facilitates the parameter tuning of the models.
4. It uses the GPU to accelerate the computation.
5. Working together with the Hugn middleware (<http://gforge.inria.fr/projects/cycabtk>), it can run on our experimental vehicle in real-time.

The software is developed in C/C++ in Linux and its architecture is shown in Fig.2.

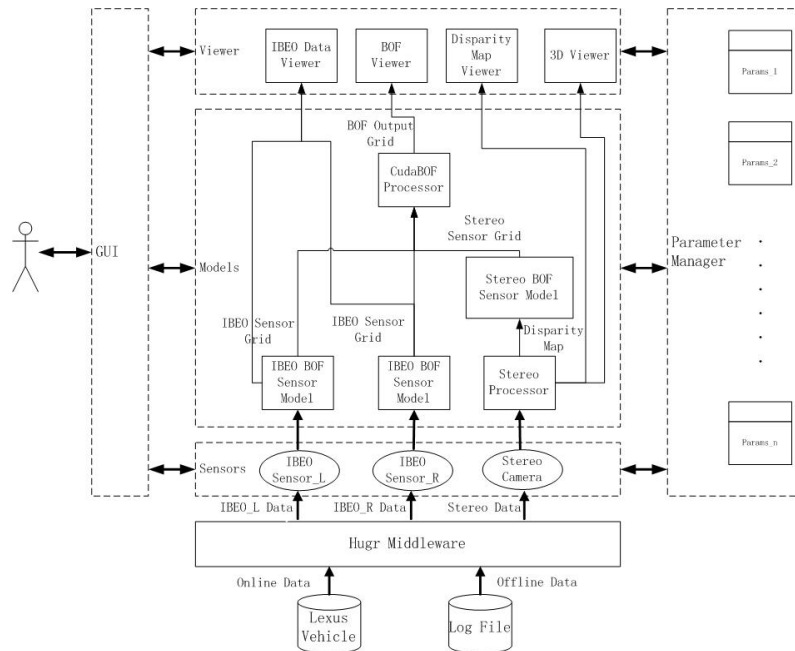

Figure 2. Architecture of ArosdynTestSuite software

In this example, we demonstrate a typical sensor fusion application. We retrieve the raw data from the Hugr middleware and store them in individual sensor objects. Then, by using this framework, we integrate the IBEO Bayesian Occupancy Filter (BOF) sensor model, the stereo sensor processor model, the stereo BOF sensor model and the BOF model together. Finally, different aspects of the computational results are visualized in several viewers. At the same time, all the parameters used by the algorithms can be tuned online.

Several windows of this application are shown in Fig. 3. Here we demonstrate the main window, the 2D viewer of the stereo camera and the lidar, the disparity map of the stereo vision and the compounded BOF grid which is the result of the sensor fusion.

Another important property of this software is a large part of the computation task executed on GPU. As the processing of stereo image and the computation in the BOF can be highly parallelized, we run these tasks on the GPU to improve the time performance, as shown in Fig. 4. In this way, the software can work in real-time.

The GPU calculation is based on CUDA library and is carried out in an independent thread. The schematic graph of the GPU computational thread is shown in Fig. 5.

Furthermore, thanks to the deliberated design of the software, we can easily add new models to it and let them work together. The fast detection and tracking algorithm (FCTA) and the Gaussian process based collision assessment algorithm are added into this framework.

4.3. Bayesian Occupancy Filter

People involved: Kamel Mekhnacha, Tay Meng Keat Christopher, C. Laugier, M. Yguel, Pierre Bessi re.

The BOF toolbox is a C++ library that implements the Bayesian Occupancy Filter. It is often used for modelling dynamic environments. It contains the relevant functions for performing bayesian filtering in grid spaces. The output from the BOF toolbox are the estimated probability distributions of each cell's occupancy and velocity. Some basic sensor models such as the laser scanner sensor model or Gaussian sensor model for

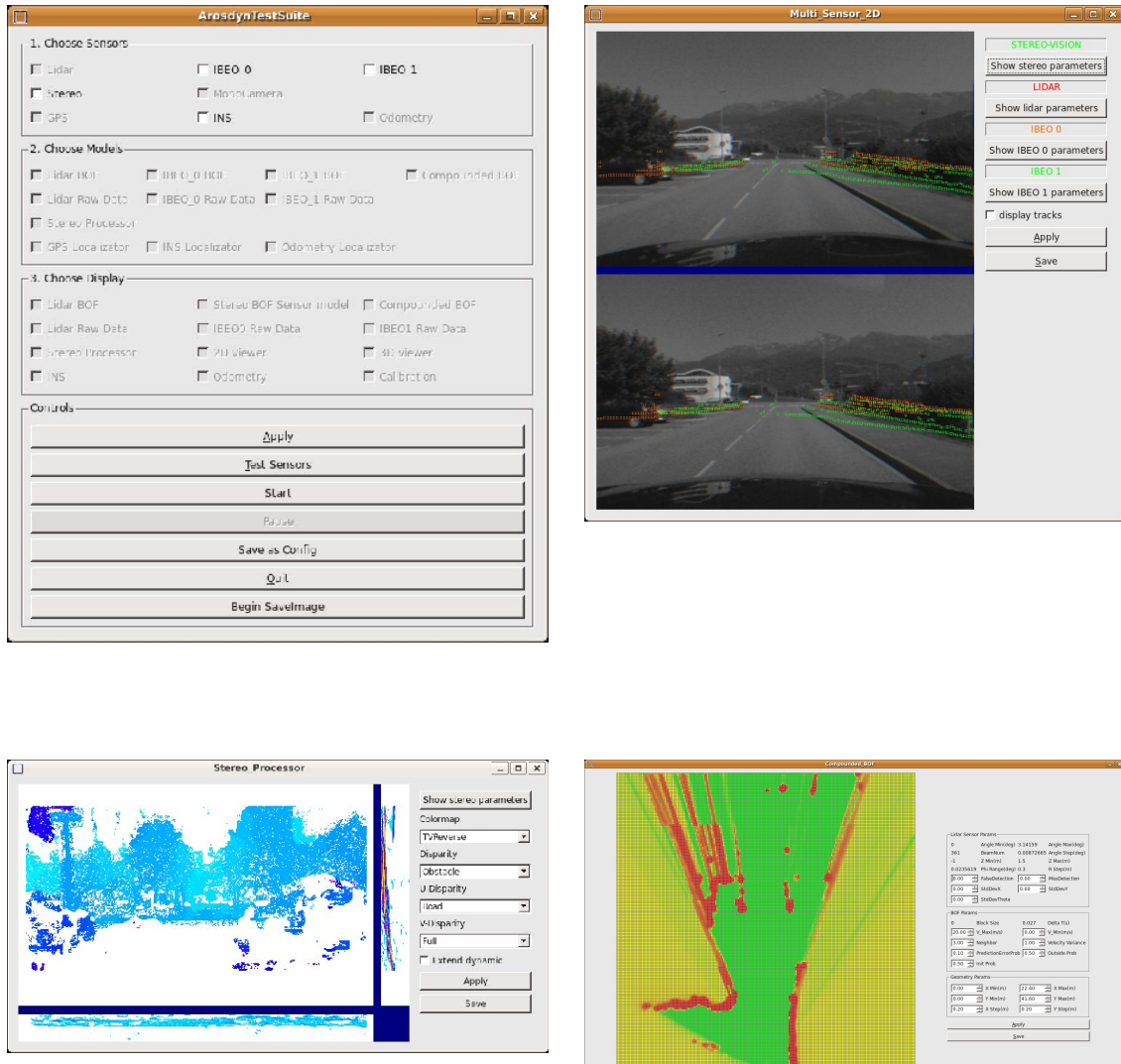

Figure 3. Windows of the ArosdynTestSuite software

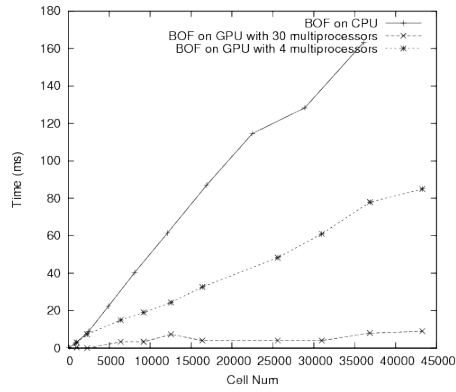

Figure 4. Time performance of BOF on GPU

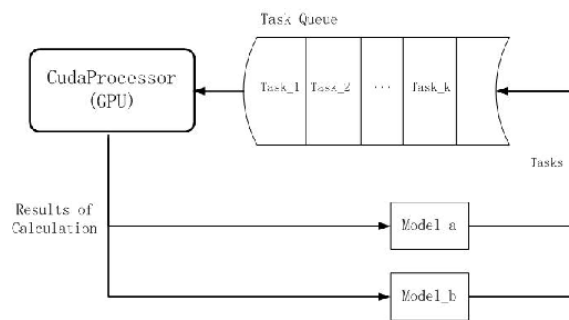

Figure 5. The GPU computational thread

gridded spaces are also included in the BOF toolbox. The sensor models and BOF mechanism in the BOF toolbox provides the necessary tools for modelling dynamic environments in most robotic applications. This toolbox is patented under two patents : “Procédé d’assistance à la conduite d’un véhicule et dispositif associé” n. 0552735 (9 september 2005) and “Procédé d’assistance à la conduite d’un véhicule et dispositif associé amélioré” n. 0552736 (9 september 2005) and commercialized by ProBayes.

- Version: 1
- Patent: 0552736 (2005), 0552735 (2005)
- Programming language: C/C++

4.4. PROBT

People involved: Juan-Manuel Ahuactzin, Kamel Mekhnacha, Pierre Bessière, Emmanuel Mazer, Manuel Yguel, Christian Laugier.

ProBT is both available as a commercial product (ProBAYES.com) and as a free library for public research and academic purposes (<http://emotion.inrialpes.fr/BP/spip.php?rubrique6>). Formerly known as *OPL*, *ProBT* is a C++ library for developing efficient Bayesian software. It is available for Linux, Unix, PC Windows (Visual C++), MacOS9, MacOSX and Irix systems. The ProBT library (<http://www.probayes.com/>) has two main components: (i) a friendly Application Program Interface (API) for building Bayesian models, and (ii) a high-performance Bayesian Inference Engine (BIE) allowing to execute all the probability calculus in exact or approximate way. *ProBT* is now commercialized by our start-up *Probayes*; it represents the main Bayesian programming tool of the *e-Motion* project-team, and it is currently used in a variety of external projects both in the academic and industrial field (e.g. for the European project BACS and for some industrial applications such as Toyota or Denso future driving assistance systems).

5. New Results

5.1. Dynamic World Perception and Evolution Prediction

5.1.1. Environment modeling and sensor data acquisition

Participants: Igor Paromtchik, Christian Laugier, Mathias Perrollaz, Amaury Nègre, John-David Yoder.

An overall architecture of our environment-modeling module with the inputs from heterogenous sensors is shown in Fig. 6. The combined use of two lidars and stereo-vision helps mitigate uncertainty and allows for detection of partially occluded objects. The data processing includes the computation of probabilistic occupancy grids for each sensor and their subsequent fusion with the Bayesian Occupancy Filter (BOF). The output of the module is an estimation of the position, velocity and associated uncertainty of each observed object, which are used as input to the risk assessment module.

This architecture is implemented on our experimental platform, a Lexus LS600h car shown in Fig. 7. The vehicle is equipped with a variety of sensors including two IBEO Lux lidars placed toward the edges of the front bumper, a TYZX stereo camera situated behind the windshield, and an Xsens MTi-G inertial sensor with GPS.

The stereo camera baseline is 22 cm, with a field of view of 62°. Camera resolution is 512x320 pixels with a focal length of 410 pixels. Each lidar provides four layers of up to 200 impacts with a sampling period of 20 ms. The angular range is 100°, and the angular resolution is 0.5°. The on-board computer is equipped with 8GB of RAM, an Intel Xeon 3.4 GHz processor and an NVIDIA GeForce GTX 480 for GPU. The observed region is 40 m long by 40 m wide, with a maximum height of 2 m. Cell size of the occupancy grids is 0.2x0.2 m.

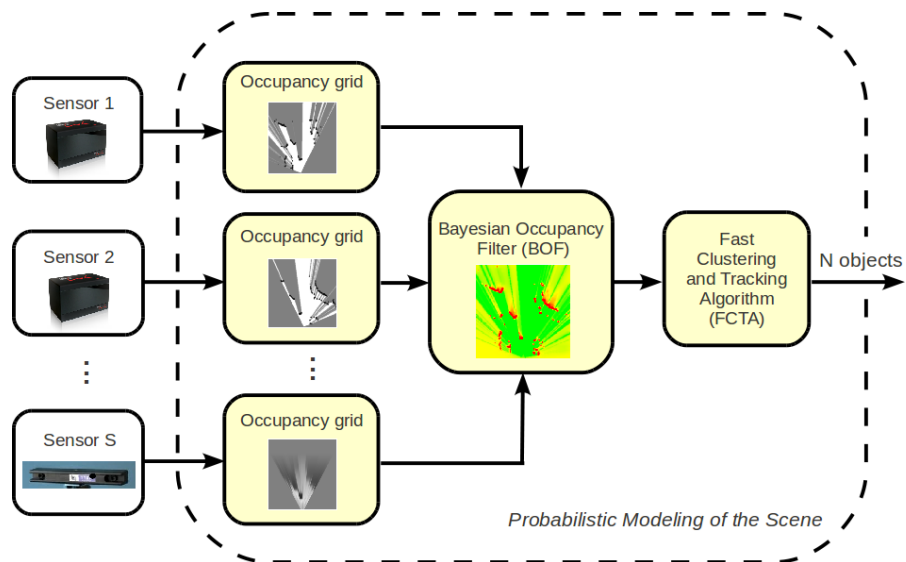

Figure 6. Architecture of the environment modeling module.



Figure 7. Lexus LS600h car equipped with two IBEO Lux lidars, a TYZX stereo camera, and an Xsens MTi-G inertial sensor with GPS.

The Lexus experimental platform provides to acquire sensor data in real traffic environments: eight layers of laser scans, stereo images, IMU data (accelerations), velocity, GPS position, steering angle. The experiments are conducted in various road environments (country roads, downtown and highway), at different time of the day, with various driving situations (light traffic, dense traffic, traffic jams). The datasets are acquired online and are used for testing of our sensor fusion and risk assessment algorithms.

5.1.2. Bayesian fusion of visual and telemetric information

Participants: Igor Paromtchik, Christian Laugier, Mathias Perrollaz, Amaury Nègre.

5.1.2.1. Concept of BOF and obstacle detection in occupancy grids

Obstacle detection is a widely explored domain of mobile robotics. It presents a particular interest for the intelligent vehicle community, as it is an essential building block for Advanced Driver Assistance Systems (ADAS). In the ANR project LOVE (Logiciel d'Observation de Vulnérables) and ArosDyn project, the e-Motion team proposed to perform obstacle detection within the occupancy grid framework. In order to work efficiently with occupancy grids, we have previously developed a probabilistic framework with the Bayesian Occupancy Filter (BOF) [40] [88] (patent 0552736 (2005)), which provides filtering, data fusion, and velocity estimation capabilities while allowing for parallel computation. The Fast Clustering and Tracking Algorithm (FCTA) [73] is then used to identify and track individual objects. The BOF is designed with the intent of its implementation in hardware as a system-on-chip. Like other grid based approaches, the BOF framework performs sensor fusion at the cell level [40]. The BOF evaluates probabilities of both *cell occupancy* and *cell velocity* for each cell in a four-dimensional spatio-temporal grid. The monitoring of traffic scenes includes detection and tracking of objects by the FCTA [73].

Fig. 8 shows examples of occupancy grid mapping with the proposed approach. The arrows indicate the pedestrian, the car, and the bicycle, which appear in the camera images and the occupancy grids. Because the accuracy of stereo-vision tends to become poor at large distance, the corresponding grid has been attenuated beyond 20 m and the system is tuned to give more confidence to the lidars than to the stereo-vision. One of advantages of sensor fusion is a larger viewfield so that the vehicles overtaking the ego-vehicle (they are not seen in the camera images) are correctly mapped on the resulting BOF grid. Moreover, the sensor fusion as well as the Bayesian estimation provide to filter out the laser impacts with the road surface, e.g. right lidar in Fig. 8.

Note that a large number of dynamic objects in the traffic scenes may lead to a failure of object-based fusion because of a large number of association hypotheses. The grid-based approach allows us to avoid the object association problem for sensor fusion.

5.1.2.2. Disparity space approach for a vision based occupancy grid

Participants: Mathias Perrollaz, Anne Spalanzani, John-David Yoder, Amaury Nègre, Christian Laugier.

To use sensors in the BOF framework, it is essential to develop an associated probabilistic sensor model that takes into consideration the uncertainty over measurements. In 2009, we proposed such a sensor model for stereo-vision [79]. The originality of the approach relied on the decision to work in the disparity space, instead of the classical Cartesian space. In 2010, we improved our sensor model, in order to mimic some features of the sensor models used for range finders. Particularly, we worked on managing visible/occluded areas of the scene [81], and on including the information from the road/obstacle segmentation of the disparity image [80]. Our approach was also designed to allow highly parallel computation of the occupancy grid. A. Nègre implemented the approach on GPU using NVIDIA CUDA to enhance the performance. The complete processing of the stereo data can now be done in 6 ms, while more than 150 ms were necessary with the CPU implementation. The complete approach for occupancy grid computation using stereovision is described in [30].

Figure 9 shows an example of the occupancy grid computed by our new approach. We can observe that most objects are detected (light color), even if partially occluded (e.g. the sign on the right). Information from the road surface is also taken into consideration (dark areas). Moreover, similar to a laser scanner, it appears that regions in front of objects are seen as partially unoccupied, while less information is available behind obstacles (occupancy probability is closer to 0.5).

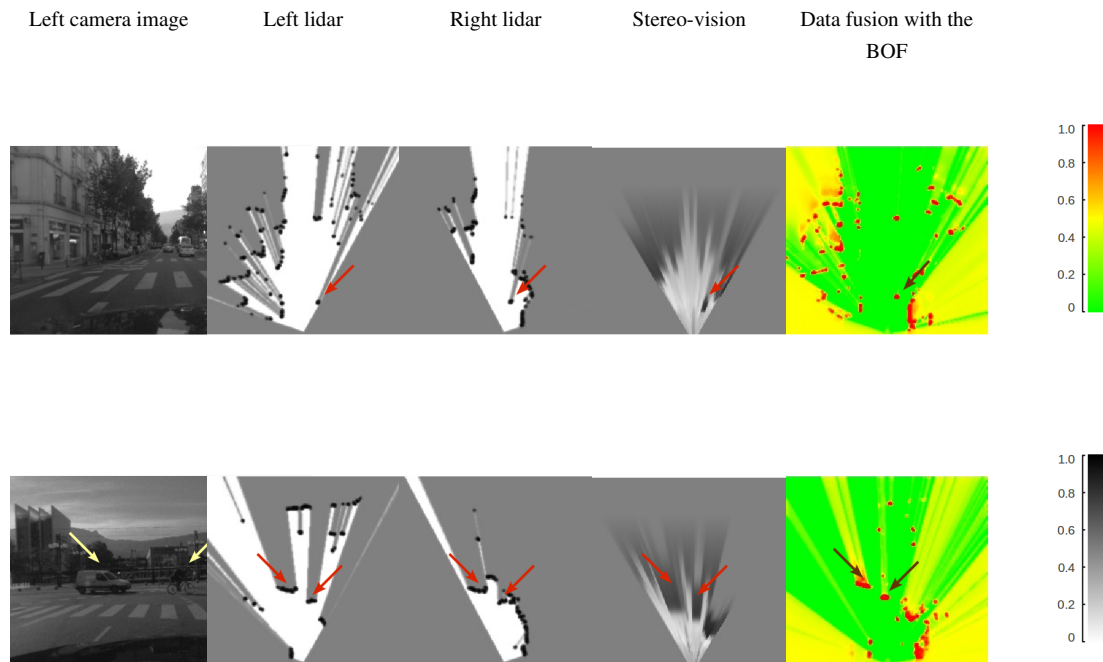

Figure 8. Examples of occupancy grid mapping in typical urban traffic scenes, from left to right: left image from the stereo pair, an occupancy grid from the left lidar, an occupancy grid from the right lidar, an occupancy grid from stereo-vision, an occupancy grid estimated by data fusion with the BOF, and a probability scale.

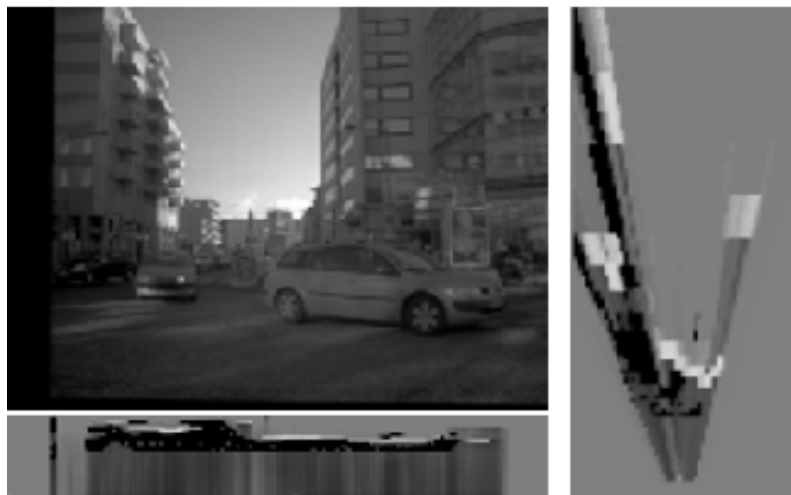
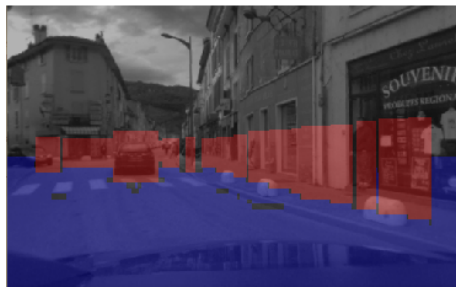

Figure 9. Example of an occupancy grid computed with our new approach. a) the left image from a stereo pair. b) the occupancy grid computed in the u -disparity plane, and c) the corresponding grid mapped into cartesian space. Light colors correspond to areas with a high probability of occupancy, while dark colors are for low occupancy probability

In 2011, we focused on including the approach into the risk estimation framework on our Lexus experimental platform. We implemented a demonstration to estimate a distance measurement to the closer object situated in the future trajectory of the vehicle. The future trajectory is estimated either by using a lane detection algorithm (in the highway) or by combining velocity and steering information of the vehicle. Figure 10 shows the HMI displayed in the car while driving.



a)



b)

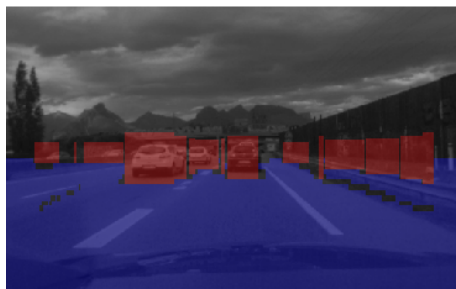

c)

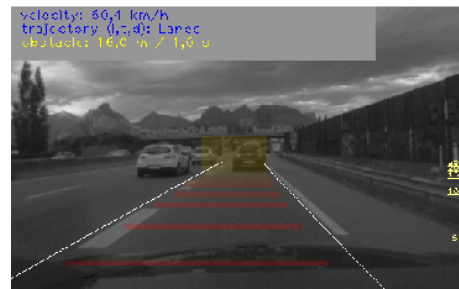

d)

Figure 10. a) segmentation of the environment with the stereo-vision algorithm. Blue areas belong to the road surface, while red areas belong to the obstacles. b) HMI shown in the car during the demonstration of risk estimation. The trajectory is estimated by considering the velocity and steering angle of the ego vehicle. Here the car in front is not considered as dangerous because it is more than 2 seconds ahead. c-d) Another example, on the highway. For this example, the trajectory is estimated by considering the road markings.

5.1.2.3. Processing of multi-layer telemetric data in probabilistic framework

Participants: Mathias Perrollaz, Juan-David Adarve, Alexandros Makris.

The occupancy grid computation based on a laser scanner uses the classical independent beam sensor model [90]. Since our vehicle is equipped with two four-layers laser scanners, it is necessary to merge the data from the multiple layers. In the original BOF framework, the fusion was performed through the classical Bayesian Fusion methodology. As shown in figure 11, this method causes problems of misdetection when some beams go over an object. In 2011, we proposed and implemented another approach. The fusion is now obtained through a weighted sum of the the occupancy grids provided by each layer. The weight of each layer is obtained by computing a confidence grid. This confidence depends both on the inclination of the layer and on the possible occlusions. The new approach provides a more precise description of the environment.

5.1.3. Sensor Fusion and parameters estimation

Participants: Agostino Martinelli, Chiara Troiani.

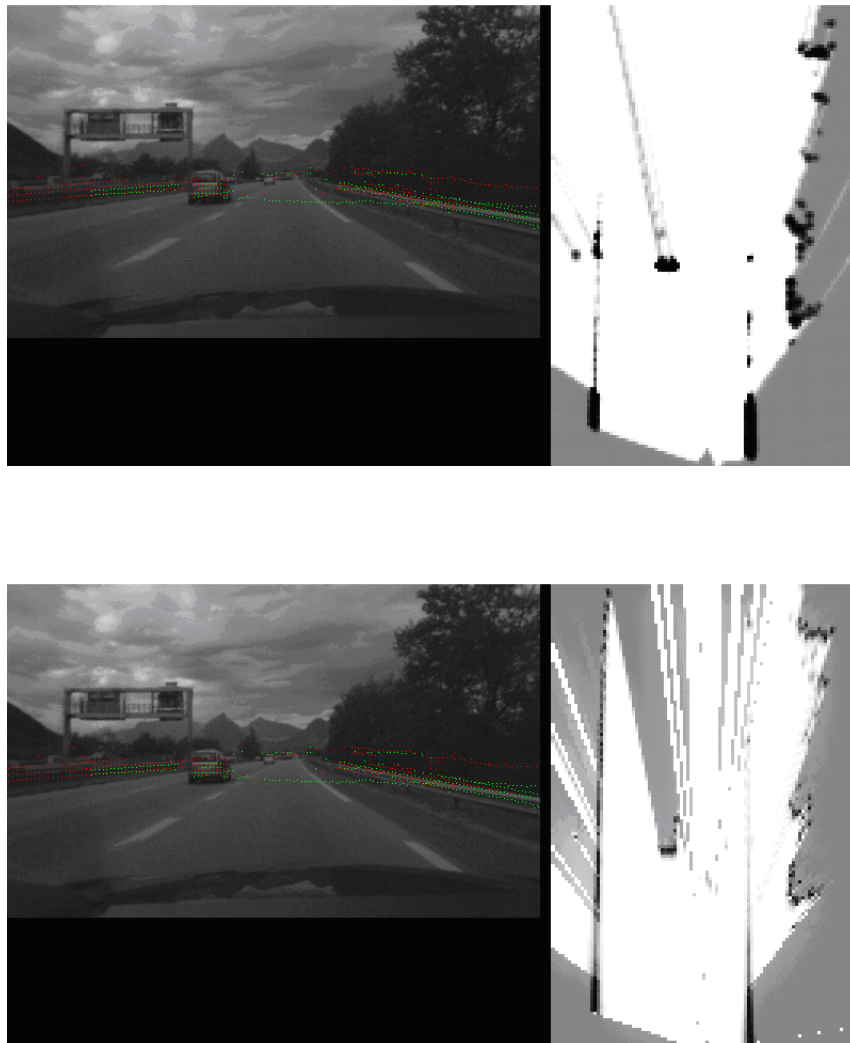

Figure 11. Occupancy grid computed after fusion of eight layers of laser data. Above: with the previous approach, some objects are not correctly represented (e.g. the barrier on the left). Below: with the new approach, the description is more precise.

This is the follow up of the research activity started in 2009, when a self-calibration problem for a wheeled robot has been investigated. The main results achieved during that year were published in [69], [71] and [70]. This calibration problem allows us to introduce a general framework able to deal with any estimation problem. This framework is based on a new theoretical concept, the concept of continuous symmetry. Detecting the continuous symmetries of a given system has a very practical importance. It allows us to detect an observable state whose components are non linear functions of the original non observable state. The general theory has been developed during the last two years. Preliminary results have been published in 2010 [72] and a more complete version of these results, which include several extensions, has been published on *Transaction on Robotics*, in 2011 [9].

In 2011, this general framework has been extensively applied to investigate the problem of the fusion of visual and inertial data in the framework of the European project sFly. Special emphasis has been devoted to the structure from motion problem (SfM) when fusing these data. This problem has particular interest and has been investigated by many disciplines, both in the framework of computer science ([35], [54], [56], [87] and references therein) and in the framework of neuroscience and vision perception ([67], [95] and references therein). Even though prior work has answered the question of which are the observable modes, i.e. the states that can be determined by fusing visual and inertial measurements [35], [54], [56], the questions of how to compute these states in the absence of a prior, and of how many solutions are possible, were still unanswered. During 2011, we have derived, for the first time, a closed form solution to the SfM problem in this case, allowing the determination of the observable modes without the need for any prior knowledge. The proposed solution analytically expresses all the observable modes in terms of the visual and inertial measurements acquired during a given (short) time-interval allowing the determination of all the observable modes without the need for any prior knowledge. Additionally, we have shown that this problem can have a unique solution or two distinct solutions or infinite solutions depending on the trajectory, on the number of point-features and on the number of monocular images where the same point-features are seen. Our results are relevant in all the applications which need to solve the structure from motion problem with low-cost sensors and which do not demand any infrastructure. Typical examples are the emergent fields of space robotics [77], humanoid robotics and unmanned aerial navigation in urban-like environments [93], where the use of the GPS is often forbidden. Furthermore, our results could play an important role in neuroscience by providing a new insight on the process of vestibular and visual integration. To this regard, we remind the reader that the influence of extra retinal cues in depth perception has extensively been investigated in the last decades. In the case when this extra retinal cue is the motion parallax induced by self-motion relative to a stationary environment, the scale factor is provided by the head velocity [65], [66]. The vast majority of these studies, consider the case when the head motion is active [38], [94]. This prevents the possibility to understand the contribution of the vestibular signals because of efference copy generated by active self movement. However, a very recent study investigates this problem by performing trials with passive head movements [43]. The conclusion of this study is that the combination of retinal image with vestibular signals can provide rudimentary ability to depth perception. Our findings could provide a new insight to this problem of depth perception since by combining retinal image with vestibular signals it is possible to determine the scale factor even without any knowledge about the initial speed. New trials would be necessary in order to verify whether a mechanism reproducing our closed form solution is present in humans and/or in other animals (especially the ones without binocular vision). Our findings also show that it is possible to easily distinguish linear acceleration from gravity. Specifically, our closed form solution perform this determination by a very simple matrix inversion. This problem has also been considered in neuroscience [75], [31]. Our results could provide a new insight to this problem since they clearly characterize the conditions (type of motion, features layout) under which this determination can be performed.

Our results have been published in three conference papers [14], [11], [15] and have been accepted for publication in *transactions on robotics* (a version is currently available as a technical report, [29]).

In parallel to this theoretical activity an experimental activity has started in order to experimentally validate our findings in the near future and to deploy our technologies to industrial partners. To this regard, a contact with the company Delta Drone in Grenoble has been established and a valorization contract with a SME in the field of civil drone applications is currently in preparation.

5.1.4. Analysis of dynamic scenes for collision risk assessment

Participants: Mathias Perrollaz, John-David Yoder, Amaury Nègre, Christian Laugier, Igor Paromtchik.

The grid-based environment representation is used for dynamic scene analysis in the Arosdyn project [78]. The original idea behind the risk estimation approach developed in the e-Motion team consists in considering the possible behaviors of the vehicles in the scene. Indeed, with the classical TTC(time to collision)-based approach, the risk is estimated based on the prediction of the trajectory, considering the current state of the objects. This is only valid for very short term predictions, and in some cases it can result in a over-estimation of the collision risk. Understanding the intention of the other participants of the road scene allows a longer term, more precise prediction of trajectories.

Our approach is divided into two steps: behavior recognition and behavior realization. The behavior recognition aims at estimating the probability for a vehicle to perform one of its feasible behaviors. The behaviors are semantic representations of driving maneuvers (e.g. turn left, turn right, go straight, ...). The probability distribution over possible behaviors is obtained by inference using layered HMMs. Driving behavior realization is modeled as Gaussian Process (GP). This model allows us to obtain the probability distribution over the physical realization of the vehicle motion (i.e. trajectories) by assuming a usual driving, for a given behavior.

Finally, a complete probabilistic model of the possible future motion of the vehicle is given by the probability distribution over driving behaviors, and by the realization of these behaviors. The risk calculation is performed by sampling of the paths from the corresponding GP. The fraction of the samples in collision gives the risk of collision.

In 2011, we conducted some early experiments on sensor fusion, using real data acquired with our Lexus experimental vehicle [16]. Moreover, the global framework of the Arosdyn project has been presented in [8].

5.1.5. Recognition for intelligent vehicles

Participants: Alexandros Makris, Mathias Perrollaz, Amaury Nègre, Igor Paromtchik, Christian Laugier.

We developed a generic object class recognition method. The method uses local image features and follows the part based detection approach. The state-of-the-art visual object class recognition systems operate with local descriptors and codebook representation of the objects. Various local features (e.g. gradient maps, edges) are used to create the descriptors. Then kernel based classifiers are commonly employed to classify the detected features in one of several object classes [32] [45]. The recognition of vehicles or pedestrians from sensors mounted on a moving platform is achieved by different approaches using various types of sensors, e.g. stereo camera, laser [51] [44]. The approaches that perform data fusion from various sensors have proven to be the more robust in a variety of road conditions [86].

This work focuses on the development of an object class recognition system which follows the part based detection approach [64]. The system fuses intensity and depth information in a probabilistic framework. To train the system for a specific object class, a database of annotated with bounding boxes images of the class objects is required. Therefore, extending the system to recognize different object classes is straightforward. We apply our method to the problem of detecting vehicles by means of on-board sensors. Initially, depth information is used to find regions of interest. Additionally, the depth of each local feature is used to weight its contribution to the posterior of the object position in the corresponding scale. The votes are then accumulated in a 3d space-scale space and the possible detections are the local maxima in that space. Figure 12 presents the steps of our approach.

The novelty of our approach is the fusion of depth and intensity information to form a probabilistic part-based detector. Using depth information is beneficial for the robustness of the approach, because we avoid including many noisy detections resulting from false matches between features of different scales. The method is tested with stereo video sequences captured in an urban environment. Fig. 13 shows some example detections. The proposed method detects side-views of cars in various scales, in cases with partial occlusions, and under significant background clutter.

5.1.6. Context-aware Bayesian estimation of risk at road intersections for cooperative vehicles

Participants: Stéphanie Lefèvre, Christian Laugier.

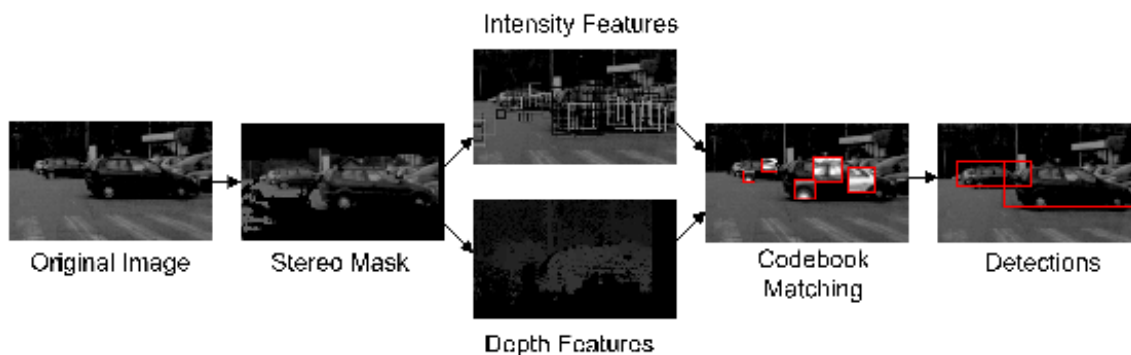

Figure 12. Detection procedure steps. The stereo information is used to define the regions of interest for the subsequent steps. Intensity and depth features are extracted from a dense grid within these regions. In the following the features are matched with the codebook clusters which are in turn used to estimate the posterior for the object in each position. The detections are the local maxima of the posterior.

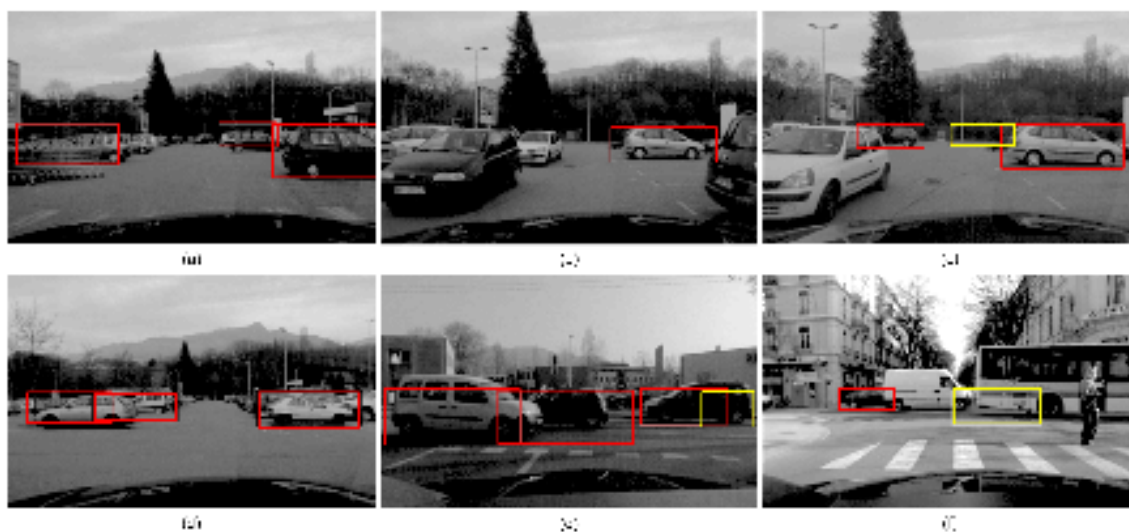

Figure 13. Car-side detection examples. True and false positive detections are represented by red and yellow bounding boxes respectively. (a) Cars in different scales with significant background clutter and significant occlusions are detected. (b) Precise detection of the un-occluded vehicle, whereas a vehicle that is heavily occluded in the left is not detected. (c) Difficult detection of a vehicle which is far and partially occluded and a false detection in the region between the road surface and the trees. (d) Detection with partial occlusion. (e) Partial detection of a taller than normal vehicle (on the left). The training dataset does not contain vehicles of this type. (f) Successful detection of a partially occluded car and a false positive arising from a bus and a van. Training separate detectors for these type of vehicles as well will help to avoid these false alarms.

The work developed in this PhD is done in collaboration with Renault (CIFRE thesis) and concerns safety applications for cooperative vehicles.

In a few years, car manufacturers will start equipping vehicles with V2X communication devices, which will allow vehicles to share information with other vehicles and with roadside units using a dedicated communication channel. This new sensor on the car opens a whole new world of possibilities for Advanced Driver Assistance Systems (ADAS). In particular, the fact that the vehicle is able to “see” a car before it even enters the field-of-view of the driver allows for a better assistance in the tasks of perceiving, analyzing, predicting, and estimating the risk of a situation.

Early in the PhD we identified safety applications at road intersections as a relevant application domain for V2X technologies. The variety and complexity of scenes at road intersections makes reasoning and interpretation particularly difficult. On the other hand, intersections are a location of many accidents (they represent up to 50% of accidents in some countries), therefore reducing the accident rates in these areas would have a considerable impact of global traffic safety. We also identified the key issues (and challenges) to be 1) situation understanding and 2) risk assessment, to be carried out from incomplete models and uncertain data.

The focus of the year 2010 was on the first of these two problems. We developed a Bayesian Network that could estimate a driver’s intended exit lane at an intersection based on the current state of the vehicle (position, orientation, turn signal state) and on contextual information extracted from the digital map. The idea was to use the information on the geometry of the road network and on the connectivity between lanes to build a statistical model of the relationship between the position and turn signal of a vehicle and the driver’s intended exit lane. Initial results of this work were published in IEEE CIVTS’11 [12], then in IEEE IV’11 [13] with a more thorough evaluation.

The objective of the work conducted in 2011 was twofold:

1. Extend the initial system: add some filtering and take into account the priority rules.
2. Estimate the risk of a situation, based on the estimated behavior/intention of the drivers in the scene.

We proposed a probabilistic motion model for vehicles approaching and traversing an intersection that incorporates some knowledge about how the context (i.e. the traffic rules, the presence of other vehicles, the geometry and topology of the intersection) influences vehicle behavior. The distinctive features of our algorithm are:

- The explicit use of priority rules

Priority rules are explicitly taken into account in the motion model: the necessity for a driver to stop and/or yield to another vehicle at an intersection is estimated, jointly with the driver’s intention to comply. This allows for a flexible and computationally inexpensive computation of risk. Flexible because depending on the final application one can decide to compute different types of risk, e.g. the probability that a specific vehicle is a violator, or the probability that a crash will occur between two vehicles, or the risk of a specific maneuver for a vehicle. Inexpensive because these can be computed without performing trajectory prediction for the vehicles in the scene.

- The assumption that drivers generally respect traffic rules

Instead of making the classical assumption that vehicles’ trajectories are independent, we model their mutual influences by introducing a prior knowledge that drivers generally respect priority rules. The motion model therefore takes into account the priority rules and the presence of other vehicles to better interpret correctly a vehicle’s behavior. The advantages are twofold. Firstly, we are able to better estimate the maneuver intention of the drivers, which means our situation assessment capabilities are improved. Secondly, risk is estimated with a higher sensitivity. We avoid risk overestimation while still being able to detect dangerous situations as well as the conventional, more conservative, methods.

This reasoning is implemented using a Bayesian filter which estimates the hidden variables M (maneuver intention), D (distance to intersection), H (intention to stop) and H’ (necessity to halt) jointly for all the vehicles in the scene, using the position, speed and heading information shared between the vehicles via

V2X communication. Inference on the hidden variables is carried out by a particle filter. The algorithm was described in an INRIA research report [27]. In this report we showed by reasoning on theoretical scenarios that our assumption that drivers tend to respect priority rules should lead to improved situation assessment and risk assessment (see Fig. 14).

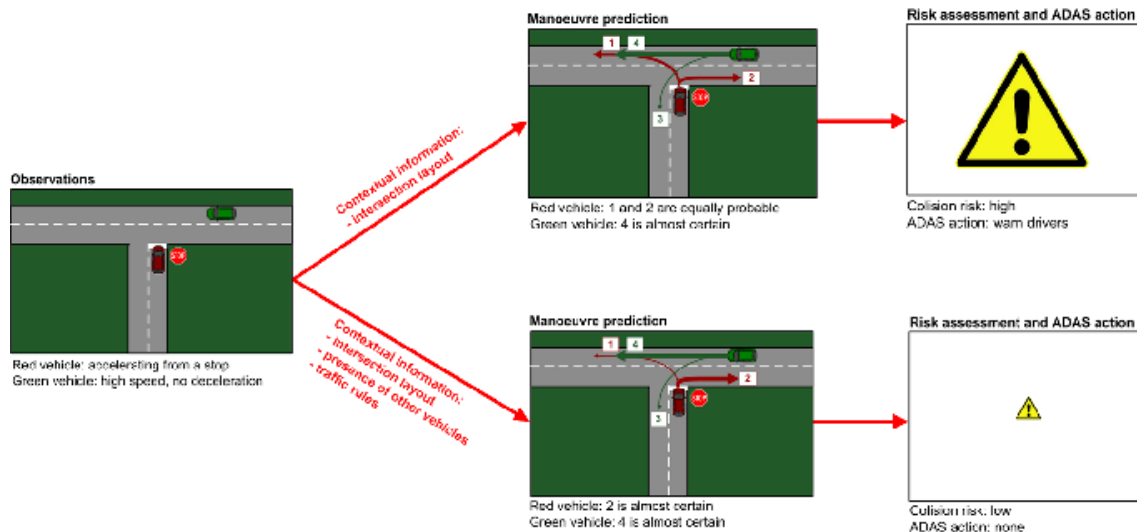

Figure 14. Illustration of a scenario where the advantage of taking into account the interactions between vehicles for maneuver prediction is obvious for ADAS applications. The behavior of the red vehicle is interpreted differently depending on whether or not the interactions with the green vehicle are considered.

Recently, data has been collected at an intersection using the Renault demonstrator vehicles, so that our algorithm can be tested on real data. Preliminary results seem to confirm that the intuitions described in the research report were correct. A Graphical User Interface is in the process of being developed so that demonstrations of the system can be carried out live in the Renault demonstrator vehicles (see Fig. 15).

5.2. Human Centered Navigation in the physical world

5.2.1. Goal oriented risk based navigation in dynamic uncertain environment

Participants: Anne Spalanzani, Jorge Rios-Martinez, Amaury Nègre, Arturo Escobedo-Cabello, Christian Laugier.

Navigation in large dynamic spaces has been addressed often using deterministic representations, fast updating and reactive avoidance strategies. However, probabilistic representations are much more informative and their use in mapping and prediction methods improves the quality of obtained results.

Since 2008 we have proposed a new concept to integrate a probabilistic collision risk function linking planning and navigation methods with the perception and the prediction of the dynamic environments [47]. Moving obstacles are supposed to move along typical motion patterns represented by Gaussian Processes or Growing HMM. The likelihood of the obstacles' future trajectory and the probability of occupation are used to compute the risk of collision. The proposed planning algorithm, call Risk-RRT, is a sampling-based partial planner guided by the risk of collision. Results concerning this work were published in [48] [49] [50].

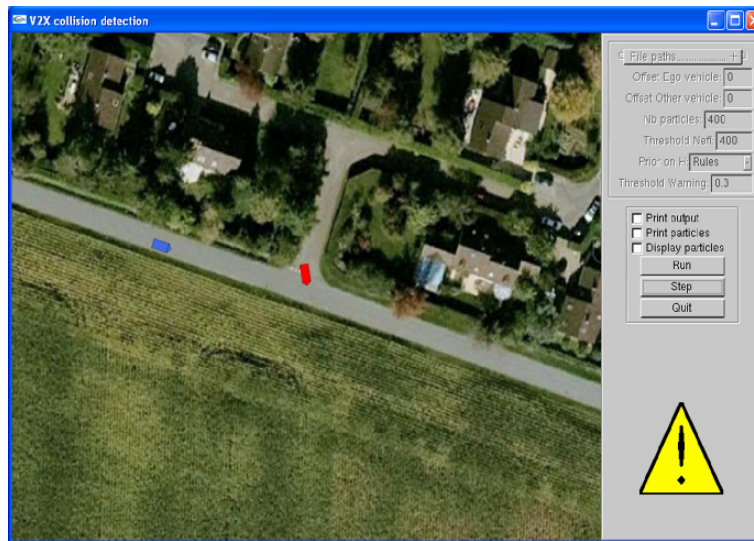

Figure 15. Graphical User Interface for warning a driver of a violation of priority rules at an intersection (the violator vehicle is displayed in red).

In 2011, our algorithms were integrated into an embedded software architecture for social aware navigation (see fig. 16). For this purpose we started to migrate our algorithms to a new experimental platform. Moreover, we adapted the code to the open source software called ROS (Robot Operating systems ²) which offers tools to develop robot applications based in state of the art algorithms. Particularly, localization and visualization tools have been used. We have linked the control of our robotic wheelchair, the Risk-RRT planning and the social filter modules described in 5.2.2 into the framework ROS as shown in figure 16. The main objective was to increase the visibility of our approach and develop common libraries with research groups in robotics. In 2011, in the scope of the AEN PAL project, we started a collaboration with the EPI Arobas and complementary developments have been put on the INRIA forge.

Next two sections are conducted under the french project PAL “Personally Assisted Living” with a goal to enhance the quality of living by providing more autonomy in the daily activities of the disabled.

5.2.2. Social conventions based navigation

Participants: Jorge Rios-Martinez, Anne Spalanzani, Christian Laugier.

The objectives of this work are to integrate the notion of *comfort* in the classical *safe navigation* methods. If one consider that the navigation system transports a person, the integration of social conventions in the navigation strategy starts to be crucial. In this work, we propose to integrate the notions of personal space and interaction between people. We propose to enrich the knowledge the robot has, with a representation of the social conventions. The robot must take into consideration interactions to avoid groups of people (even if passing through the group is the “best” path for a conventional planning algorithm), or to join a group with a behavior close to the one of a human. To understand the behaviors of interaction between humans and the management of space, the works developed in the area of sociology to define some concepts as *Personal space*, *o-space* and *F-formations* are used.

- Personal Space

²Willow Garage Inc., <http://www.ros.org>

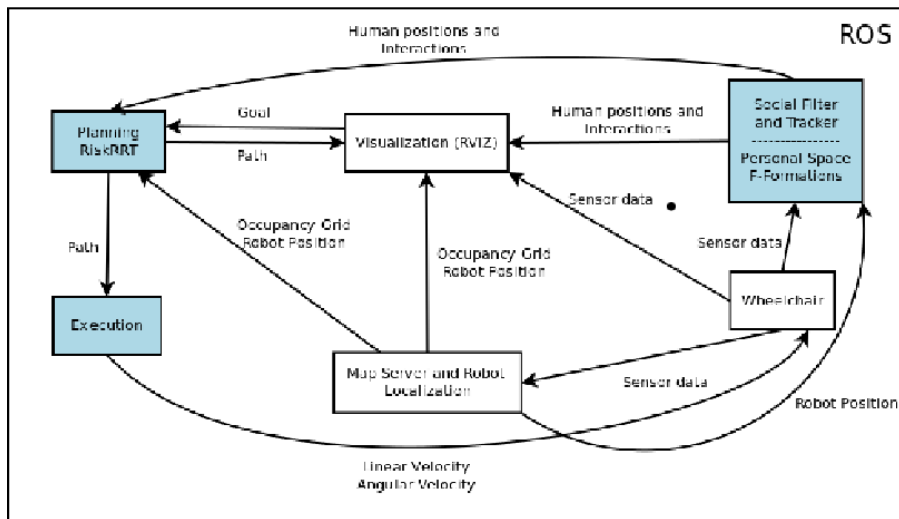

Figure 16. Architecture for the social navigation system in ROS

In [53], Hall describes the use of space between humans, he observed the existence of some rules that conducted people to keep distances from others. He proposed a classification of the space around a person (its *Personal Space*) in social interaction in four zones:

- the public zone $> 3.6\text{m}$,
- the social zone $> 1.2\text{m}$
- the personal zone $> 0.45\text{m}$
- the intimate zone $< 0.45\text{m}$

This is a useful tool for a robot to understand the intentions of the humans. It is well known that these measures are not stricts and that they change depending on age, culture and type of relationship but the categories proposed explain very well reactions like the uncomfortable sense of a stranger invading your intimate zone or the perception of somebody looking social interaction because he is entering to your social zone.

- F-formation

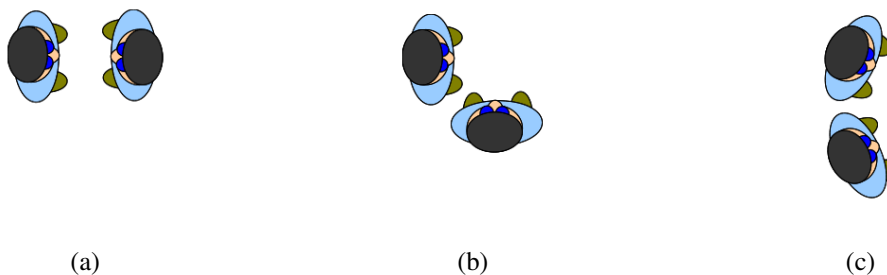

Figure 17. Examples of F-formations: (a) Vis-a-vis, (b) L-Shape, (c) C-Shape.

In [57], Kendon observed that people interacting in groups follow some spatial patterns of arrangement. When people are executing some activity they claim an amount of space related to that activity, this space is respected by other people and Kendon referred it as individual's *transactional segment*. This *transactional segment* can vary depending on body size, posture, position and orientation during the activity. Moreover the groups can establish a joint or shared *transactional segment* and only the intervenants have permitted access to it, they protect it and others tend to respect it. The *o-space* is that shared *transactional segment*. A F-formation system is the spatial-orientation arrangement that people create, share and maintain around their *o-space*. We can see in fig. (17) three examples of F-formations.

The first stage in order to achieve an integration of social concepts with robot navigation was to include estimations of the risk of disturbing personal space and interaction space in the general risk estimation. A strategy to detect interactions in the environment based in the velocity, position and orientation of humans was implemented.

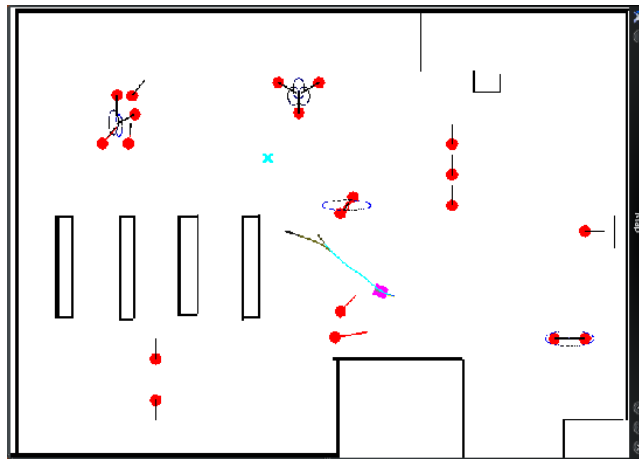

Figure 18. Detecting conversations in the environment lets the robot to take navigation decisions that avoid humans activity interruption

In fig. 18 we observe the results of the proposed integration, the robot (green rectangle) can use the detections of conversations (light ellipses) between humans (blue circles) for add more risk to paths that invade the space of conversations. When a conversation is detected, a bi-dimensional Gaussian G is created to represent the interaction space, also called *o-space*, the center of this space is approximated by taking into account the the participants' poses. Then, G is used to obtain an estimation of risk of disturbing by passing around the conversation. The navigation strategy is based on the Risk-RRT algorithm. Details of this approach were published in [18].

5.2.3. Autonomous Wheelchair for the Elderly People's Assistance

Participants: Arturo Escobedo-Cabello, Anne Spalanzani, Christian Laugier.

The elderly and the disabled are expected to benefit from the new technologies in the field of autonomous navigation robotics. Normal users of electric wheelchairs will also benefit from the development of more automatic functionalities bringing an extra driving comfort, especially during delicate maneuvers such as narrow door passages. This contribution is similar to the installation of driving assistance on a car. A simple improvement of the classical powered wheelchair can often diminish several difficulties of control.

Comfort defined as a state of ease and satisfaction of bodily wants, with freedom from pain and anxiety, has recently emerged as a design goal in autonomous navigation systems. Designers are becoming more aware of the importance of the user when scheming solution algorithms. The idea of comfort is especially important in the case of wheelchairs where the occupants are weak as result of their age or disease.

For any robot that is designed to transport people, the trajectory should be smooth and correspond to the user's understanding as much as possible. Since human interpretation of the environment often differs from a robot's interpretation, the decisions taken by the system might seem incomprehensible to a human observer. For example an autonomous vehicle could refuse to move forward due to some obstacle, while a human user would easily be able to move its way through. This undesirable behaviors may prove irritating and with time may lead to users stopping from using the system.

In 2011 we setup a robotic wheelchair as a trial platform. The wheelchair is a differential drive robot equipped with a SICK LMS-200 lidar to get 2D range information from the environment, odometry sensors, and a velocity controller we have also added a kinect sensor in order to perform some in the field of social interactions. Some basic functions can be executed including the mapping of the environment using a Rao-Blackwellized Particle Filter [52], localization using an Adaptive Monte Carlo Localization approach (AMCL) [91], global planning using an A* algorithm [60] and local reactive planning using the Dynamic Window Algorithm [46].

Alongside we started working with the kinect sensor to detect and track people. Using the given tracking information, the wheelchair is able to follow a human located in front of it. This behavior is aimed to bring assistance not only to the user but also to the caregiver by allowing him to move without pushing the wheelchair. The technical implementation of the related approaches has been done on the basis of the ROS middleware due to easy integration with other opensource robotics software which benefit sharing and testing developed software.

In 2012 we shall focus on the estimation of the user intentions by learning models of behavior. We'll then use these models to propose an adaptive autonomous navigation method that best answer the user needs.

5.2.4. Multi-Robot Distributed Control under Environmental Constraints

Participants: Agostino Martinelli, Alessandro Renzaglia.

This research has been carried out in the framework of the European project sFly. In recent years it is revealed more and more the importance of using multi-robot systems for security application, otherwise impossible to be performed by a single robot.

The main problem approached is the optimal surveillance coverage of an unknown and complex environment, i.e. finding the optimal deployment for the robots and the way to safely reach such configuration. The solution for the 2D case without obstacles is already known in literature [39]. On the other hand, for the non-convex case, it is still a difficult problem. In [84] we firstly proposed a possible strategy based on a combination of the repulsive potential field method and the Voronoi partition. Then, in the last two years we have mainly approached the coverage problem by using a new stochastic optimization method. This work is in collaboration with professor Elias Kosmatopoulos, from CERTH (Thessaloniki), and professor Lefteris Doitsidis, from TUC (Crete), partners in the sFly project.

The Kosmatopoulos's group has proposed a new adaptive stochastic optimization algorithm for a general class of multi-robot passive and active sensing applications [59], [58]. This method possesses the capability of being able to efficiently handle optimization problems for which an analytical form of the function to be optimized is unknown, but the function is available for measurement at each iteration of the algorithm employed to optimize it. As a result, it perfectly suits for multi-robot optimal coverage in non-convex environments, where the analytical form of the function to be optimized is unknown but the function is available for measurement (through the robots' sensors) for each multi-robot configuration.

The main results obtained for the 2D case by using this method has been published in [85], [83]. We assume the robots are equipped with global positioning capabilities and visual sensors able to monitor the surrounding environment. The goal is to maximize the area monitored by the team, by identifying the best configuration of

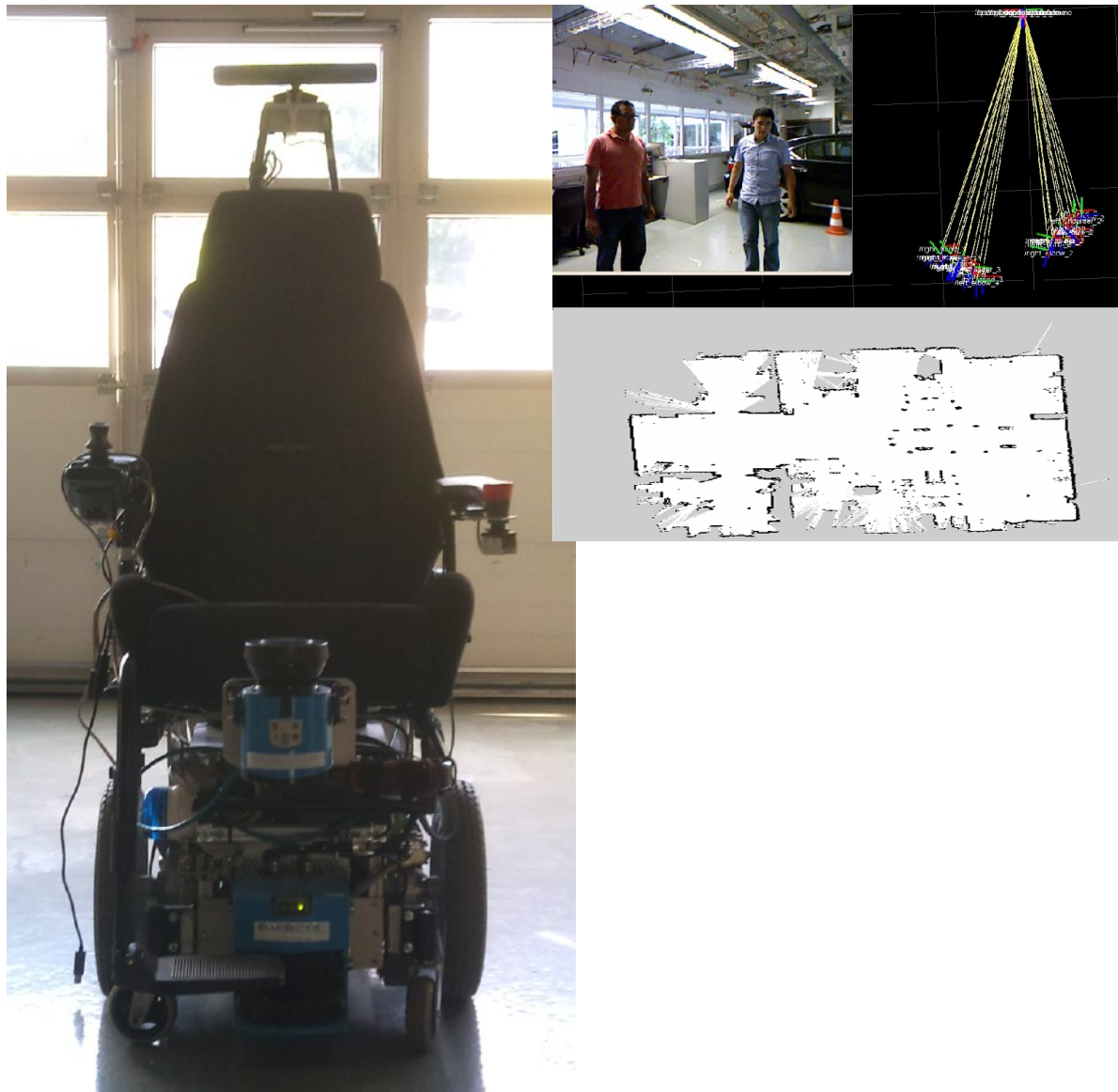

(a)

(b)

Figure 19. (a) Wheelchair used in the emotion team, (b) Two people being tracked using the Kinect and the map of the environment done by the wheelchair.

the team members. Moreover, in 2011, a distributed version of the algorithm was presented in [17]. In multi-robot systems, a distributed approach is desirable for several fundamental reasons. The most important are failure of the central station and limited communication capabilities. The proposed approach has the following key advantages with respect to previous works:

- it can solve the problem in a distributed way;
- it does not require any a priori knowledge on the environment;
- it works in any given environment, without the necessity to make any kind of assumption about its topology;
- it can incorporate any kind of constraints, for instance regarding a possible existing threshold on the maximum distance on the monitored region, or a limited visibility angle;
- it does not require a knowledge about these constraints since they are learnt during the task execution;
- its complexity is low allowing real time implementations.

The previous approach has been also extended for the more important and realistic 3D case. Working in collaboration with the ETHZ (Zurich), some simulations using real data, which were collected with the use of a miniature quadrotor helicopter specially designed for the needs of the European project sFly, have been performed (see fig. 20). This work has lead to two joint publications with CERTH and TUC: one conference paper to present (CDC2011) and one journal papers under review, and two joint publications with CERTH, TUC and ETHZ: one conference paper ([10]) and one journal papers under review.

In 2011, this approach has been combined with human aware navigation technics presented in section 5.2.5.

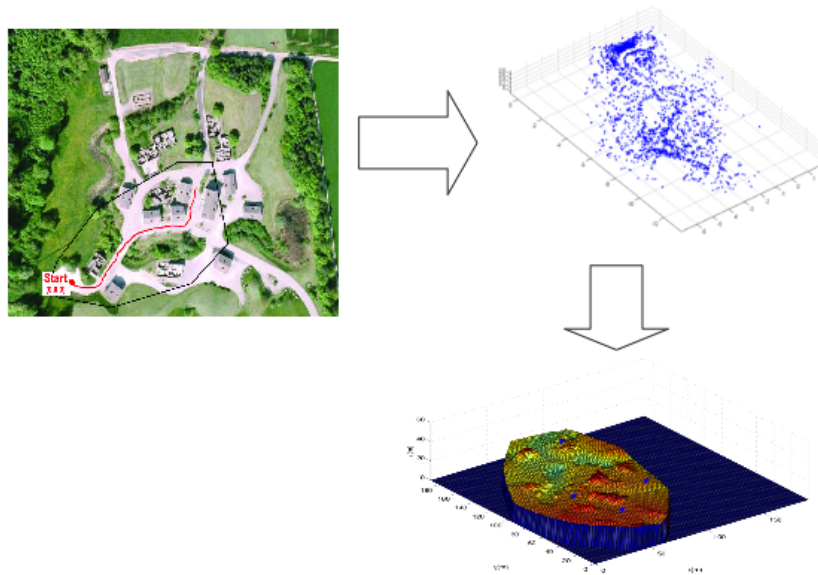

Figure 20. Cooperative surveillance coverage with a team of four robots. The surface to monitor is created using the real data collected by the helicopters. Blue triangles show the final positions, which are provided by the CAO algorithm.

In the next months, the algorithm will be implemented on real MAVs for the final demo of the project. This demo will include experimentation both in indoor and outdoor complex environments.

Finally, a new collaboration with professor Kosmatopoulos has recently begun. The objective of this work is to develop a new efficient and scalable algorithm for multi-robot active control to perform cooperative simultaneous localization and mapping (CSLAM) and target tracking. The main idea is to use a convex optimization algorithm based on Semi-Definite Programming and Sum-of-Squares polynomials. Preliminary simulation results are very promising and a journal paper is under preparation.

5.2.5. Exploring stochastic optimization method to navigate between humans

Participants: Jorge Rios-Martinez, Alessandro Renzaglia, Anne Spalanzani, Agostino Martinelli, Christian Laugier.

Suppose that we have a robot navigating in an unknown and complex environment where people are moving and interacting. In such scenario the respect of the humans' comfort becomes an important goal to achieve. The discomfort concept could be very general but we focus on the one mentioned before, i.e., the discomfort caused by disturbing one interaction or a personal space of humans. The approach here is to minimize the discomfort while the robot is navigating. As we cannot measure directly the value of discomfort, we can infer it by modeling the concepts presented before using simple equations and after by applying a method of optimization. We propose to exploit a new stochastic and adaptive optimization algorithm (CAO) [59]. This method is very useful in particular when the analytical expression of the optimization function is unknown but numerical values are available for any state configuration. Furthermore, the proposed method can easily incorporate any dynamical and environmental constraints. To validate the performance of the proposed solution, several simulation results are provided.

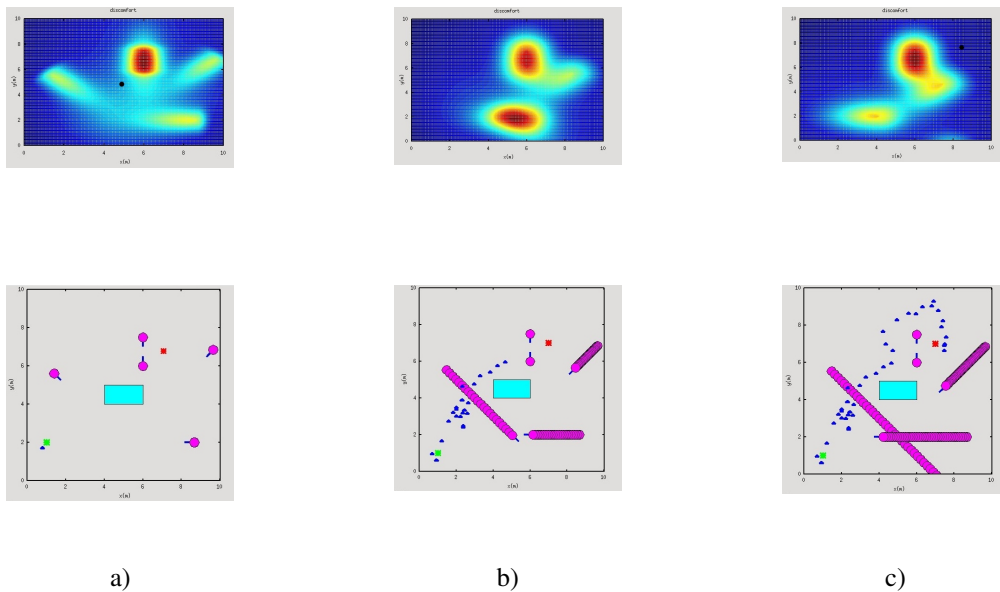

Figure 21. Simulation of the robot navigating in an environment populated by people at three different times, three humans walking and two in conversation. Above discomfort function, below image of scenario, people represented by circles, robot's positions represented by small triangle.

In fig. 21 the model for discomfort function is shown together with robot navigation. At each step the robot randomly generate configurations in the environment and selects the one that takes it closer to the goal while minimizing values for the discomfort function of humans in the environment, this is repeated until goal is reached. Several executions of proposed approach in different scenarios can be observed in fig. 22

The details of this approach have been submitted to ICRA2012.

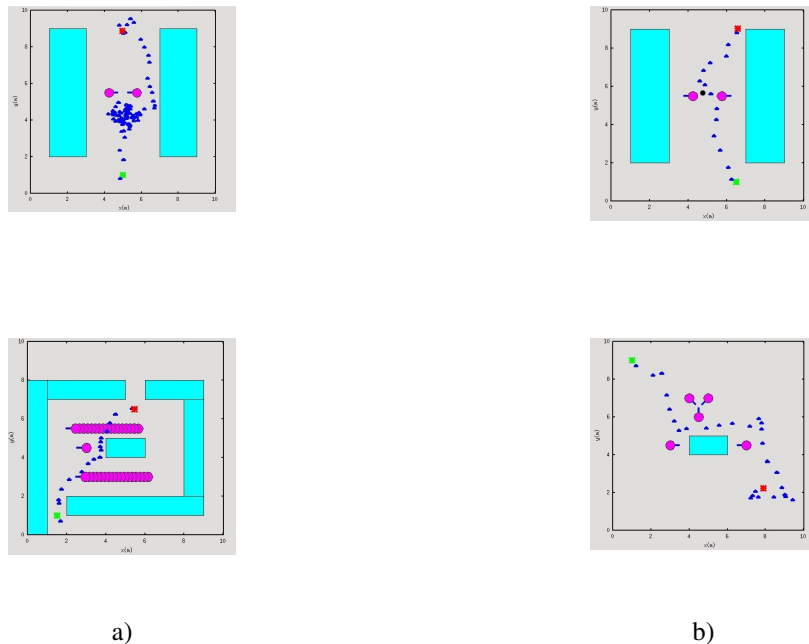

Figure 22. More simulations with different scenarios, start position in green, goal position in red. In (a) up robot decides to take a path that minimizes discomfort. In (b) robot changes its route to do not disturb human at right. Bottom, a pair of complex scenarios where paths chosen respects people comfort.

5.3. Bayesian Modelling of Sensorimotor Systems and Behaviors

Results proposed in this section were done in collaboration with the LPPA collège de France.

5.3.1. Bayesian programming applied to a multi-player video games

Participants: Gabriel Synnaeve, Pierre Bessière.

The problem addressed in this work is the autonomous replacement of a human player. It is the continuation of last year's work on the same topic as well as a follow-up of previous E-Motion Ph.D Ronan Le Hy [61]. This year, we focused on real-time strategy (RTS) games, in which the players have to build an economy, advance technology, produce and control an army to kill the opponents. From a research point of view, multi-player games are interesting because they stand for a good in-between of the real world and simulations. The world is finite and simulated (no sensors problems) but we didn't wrote the simulation and the other players are humans (or advanced robots in the case of AI competitions).

This year's research work focused on plan recognition from noisy and incomplete observations. Previous plan recognition works in multiplayer games were mainly based on planning and case-based reasoning (CBR) [92], [68], [55], [76] or HMMs [41]. CBR allows for taking domain knowledge into account easily while not dealing efficiently with uncertainty/incompleteness of information, HMMs deal with uncertainty quite well but domain knowledge is harder to structure. We found different ways to decompose the joint $P(Observation_{1:N}, Plan_{1:M})$ which allows for tractable and robust inference. For instance with the help of intermediate variables which can be derived from domain knowledge (as we did) or found automatically (e.g. cross-validation on a HMM). Particularly, we were able to structure dependencies between domain knowledge extracted variables using coherence variables. We then learn the parameters of such joint distributions from data. Supervised (labeled), and semi-supervised learning (when we label automatically from clustering) have led to a publication at CIG (IEEE) 2011 [19] and unsupervised learning (using only raw game data) led to a publication at AIIDE (AAAI) 2011 [20].

On top of the research/evaluation implementation, we also implemented it in our StarCraft: Broodwar's bot implementation BroodwarBotQ. With this bot, we took part in AIIDE and CIG conferences AI tournaments placing respectively 9th (out of 18) and 4th (out of 10). We also published last year's result on multiple units control in real-time engagements (see 23) at CIG (IEEE) 2011 [21]. As optimal micro-management is almost always intractable (P-space) in real situations, we considered each unit as a Bayesian sensory motor robot which makes a fusion of its sensory inputs about the world, the enemy units, but also its allies (without explicit communication for less complexity) and higher level directions. So the units only take short term decision on where to go and who to attack, higher level planning is done at a squad (and then army) level and given as a sensory input. Results in micro-management tournaments are state of the art. In the more general case, they could be improved by reinforcement learning of the models parameters.

We are now working on concurrent goals resources attribution, still in the context of incomplete knowledge about the opponent. We are also working on correlating low-level observations (effects) and high-level inferences (causes) about the enemy strategy to be able to predict its future behavior.



Figure 23. A real-time engagement: where should we go (we consider only the wide arrows)? Who should we fire on (we can fire only on orange arrows pointer units, while violet units are also potentially interesting targets)?

5.3.2. *Bayesian modelling to implement and compare different theories of speech communication*

Participants: Raphael Laurent, Pierre Bessière, Julien Diard, Jean-Luc Schwartz.

A central issue in speech science concerns the nature of representations and processes involved in communication. The search for phoneme or syllable specific invariants led to three major sets of approaches: motor, auditory and perceptuo-motor theories, which have been widely argued for and against. The debate appears to be stagnating. This work is based on the belief that mathematical modeling of these theories could provide breakthroughs. More precisely, it is proposed that casting these theories into a single, unified mathematical framework would be the most efficient way of comparing the theories and their properties in a systematic manner.

Bayesian modeling provides a mathematical framework that precisely allows such comparisons. The same tool, namely probabilities, can be used both for defining the models and for comparing them. Moreover, the use of a unified framework implies that common hypotheses would have common mathematical translations. This helps toward more principled studies of the competing theories.

Following this integrative approach, the motor, auditory and perceptuo-motor theories are thus cast into one unifying Bayesian framework in which they all appear as instances of various questions asked to one probabilistic communication model. This allows to compare these theories through quantitative testing in various paradigms. The work is aimed at understanding the differences in the predictions given by the different theories, and from these predictions to suggest experiments involving human subjects.

The model was used first to work on purely theoretical simulations aimed at studying with diverse paradigms the decrease in the performances predicted by the different theories due to communication noise. It was then used to work on plosive syllables production and perception, thanks to VLAM, a vocal tract simulation tool, which allows to map articulatory parameters to acoustic signals.

6. Contracts and Grants with Industry

6.1. Contracts with Industry

6.1.1. *Toyota Motors Europe*

[Feb 2006 - Feb 2009] [Dec 2010 - Dec 2014]

The contract with Toyota Motors Europe is a joint collaboration involving Toyota Motors Europe, INRIA and ProBayes. It follows a first successful short term collaboration with Toyota in 2005.

This contract aims at developing innovative technologies in the context of automotive safety. The idea is to improve road safety in driving situations by equipping vehicles with the technology to model on the fly the dynamic environment, to sense and identify potentially dangerous traffic participants or road obstacles, and to evaluate the collision danger. The sensing is performed using sensors commonly used in automotive applications such as cameras and lidar.

This collaboration has been extended for 4 years and Toyota provides us with an experimental vehicle Lexus equipped with various sensing and control capabilities.

6.1.2. *Renault*

[Jan 2010 - Feb 2013]

This contract is linked to the PhD Thesis of Stephanie Lefèvre. The objective is to develop technologies for collaborative driving as part of a Driving Assistance Systems for improving car safety. Both vehicle perception and communications are considered in the scope of this study.

6.1.3. GRAAL

[January 2009 - January 2011]

The Graal project aims to produce a generic behaviour construction toolkit for video games and small autonomous robots. It is based on probabilist modelling techniques, and will last two years, starting in January 2009. It involves four partners :

- INRIA/e-Motion provides the core scientific basis for probabilist modelling and autonomous robot programming;
- Probayes ("Born of INRIA" in 2003) builds upon its generic Bayesian inference engine ProBT, and its expertise of decision systems;
- POB-Technology develops small robots for education and entertainment, sold in high schools and universities all over the world;
- Ageod (in the project during its first year) developed simulation-like historic strategy games.

The goal of the project is the extension and application of Bayesian modelling techniques for industrial behaviour construction :

- programming and maintaining complex behaviours for virtual entities; - teaching simple behaviours to small robots;
- bringing behaviour modification into the hands of students and hobbyists;
- integrating probabilistic reasoning into the tools of industrial behaviour programmers.

The Graal project is funded as a FUI (Fonds Unitaire Interministériel) project by the French Ministère de l'Industrie, the Rhône-Alpes region, and the Greater Lyon metropolitan area. It is labelled and supported by the Imaginove (game and entertainment) and Minalogic (intelligent miniaturized products) clusters.

6.1.4. PROTEUS

[November 2009 - October 2013]

PROTEUS ("Robotic Platform to facilitate transfer between Industries and academics") is an ANR project involving 6 industrial and 7 academic partners. This projects aims to develop a software platform which helps to share methods and softwares between academics and industries in the field of mobile robotics.

The project works on three main aspects :

- Specification of different scenarios and its associated formalism.
- Definition of a domain specific language (DSL) to specify and execute the given scenarios.
- Setting up 4 robotic challenges to evaluate the capacity and the usability of the platform.

The contribution of *e-Motion* to PROTEUS is first to provide its expertise on mobile robotics to develop the DSL and next to provide a simulation environment with its platform "CycabTK".

Juan Lahera-Perez has been recruited as engineer to work on this project with Amaury Nègre.

7. Partnerships and Cooperations

7.1. National Initiatives

7.1.1. ADT ArosDyn

[Nov 2008 - Nov 2011]

The Technology Development Action (ADT) ArosDyn, coordinated by the project team e-Motion, aims to develop an embedded software for robust analysis of dynamic scenes and assessment of risk during car driving. The system will be used in the scope of a Driver Assistance System. ADT ArosDyn is supported by the INRIA's Direction of Technological Development (D2T).

The principal participants of the project are the project-teams e-Motion, PERCEPTION, the SED of INRIA Grenoble Rhône-Alpes and the project-team EVOLUTION of INRIA Sophia-Antipolis. The spin-off company Probayes and the project-team PRIMA of INRIA Grenoble Rhône-Alpes help us on the development of some specialized modules.

The robustness of the analysis methods is based on the Bayesian fusion of sensor data. The applied algorithms provide to detect and track in real time multiple moving objects in various traffic scenarios. The perception of traffic environment relies on the processing of range and visual information gathered by a laser scanner and a stereo vision camera. These two types of sensors possess complementary technical features. They ensure the detection of objects in various traffic scenarios. The proprioceptive perception makes use of the inertial and odometry sensors. The system is implemented onto our experimental vehicle Lexus which has been provided by Toyota.

7.1.2. AEN PAL

[Nov 2009 - Nov 2013]

The objective of this project is to create a research infrastructure that will enable experiments with technologies for improving the quality of life for persons who have suffered a loss of autonomy through age, illness or accident. In particular, the project seeks to enable development of technologies that can provide services for elderly and fragile persons, as well as their immediate family, caregivers and social groups.

The INRIA Project-Teams (IPT) participating in this Large-scale initiative action Personally Assisted Living (LSIA Pal) propose to work together to develop technologies and services to improve the autonomy and quality of life for elderly and fragile persons. Most of the associated project groups already address issues related to enhancing autonomy and quality of life within their work programs. This goal of this program is to unite these groups around an experimental infrastructure, designed to enable collaborative experimentation.

Working with elderly and fragile to develop new technologies currently poses a number of difficult challenges for INRIA research groups. Firstly, elderly people cannot be classified as a single homogeneous group with a single behavior. Their disabilities may be classified as not just physical or cognitive, motor or sensory, but can also be classified as either chronic or temporary. Moreover, this population is unaccustomed to new technologies, and can suffer from both cognitive and social inhibitions when confronted with new technologies. None-the-less, progress in this area has enormous potential for social and financial impact for both the beneficiaries and their immediate family circle.

The spectrum of possible actions in the field of elderly assistance is large. We propose to focus on challenges that have been determined through meetings with field experts (medical experts, public health responsible, sociologists, user associations...). We have grouped these challenges into four themes: monitoring services, mobility aids, transfer and medical rehabilitation, social interaction services. These themes correspond to the scientific projects and expectations of associated INRIA projects. The safety of people, restoring their functions in daily life and promoting social cohesion are all core motivations for this initiative.

e-Motion concentrates his work on mobility aids using the wheelchair.

7.2. European Initiatives

7.2.1. Collaborations in European Programs

7.2.1.1. BACS project

Program:FP6-IST-027140

Project acronym:BACS

Project title:Bayesian Approach to Cognitive Systems

Duration: January 2006 - February 2011

Coordinator: Agostino Martinelli, Pierre Bessi re

Other partners: LPPA, ETHZ (suisse)

Abstract: Despite very extensive research efforts contemporary robots and other cognitive artifacts are not yet ready to autonomously operate in complex real world environments. One of the major reasons for this failure in creating cognitive situated systems is the difficulty in the handling of incomplete knowledge and uncertainty. In this project we are investigating and applying Bayesian models and approaches in order to develop artificial cognitive systems that can carry out complex tasks in real world environments. We are taking inspiration from the brains of mammals including humans and applying our findings to the developments of cognitive systems. The conducted research results in a consistent Bayesian framework offering enhanced tools for probabilistic reasoning in complex real world situations. The performance is demonstrated through its applications to drive assistant systems and 3D mapping, both very complex real world tasks. P. Bessière, C. Laugier and R. Siegwart edited a book titled “Probabilistic Reasoning and Decision Making in Sensory-Motor Systems” [34] which regroups 12 different PhD theses defended within the BIBA and BACS European projects. See: [33], [36], [37], [42], [62], [63], [74], [89], [82].

7.2.1.2. Intersafe 2 project

Project acronym: Intersafe 2

Project title: Intersafe 2

Duration: September 2008 - September 2011

Coordinator: M. Parent and O. Aycard

Abstract: The INTERSAFE-2 project aims to develop and demonstrate a Cooperative Intersection Safety System (CISS) that is able to significantly reduce injury and fatal accidents at intersections.

The novel CISS combines warning and intervention functions demonstrated on three vehicles: two passenger cars and one heavy goods vehicle. Furthermore, a simulator is used for additional R&D. These functions are based on novel cooperative scenario interpretation and risk assessment algorithms.

7.2.1.3. sFly project

Program: FP7-ICT-2007-3.2.2

Project acronym: sFly

Project title: Swarm of Micro Flying Robot

Duration: January 2009 - December 2011

Coordinator: A. Martinelli

Abstract: sFly is an European research project involving 4 research laboratories and 2 industrial partners. This project will focus on micro helicopter design, visual 3D mapping and navigation, low power communication including range estimation and multi-robot control under environmental constraints. It shall lead to novel micro flying robots that are:

- Inherently safe due to very low weight (<500g) and appropriate propeller design;
- Capable of vision-based fully autonomous navigation and mapping;
- Able of coordinated flight in small swarms in constrained and dense environments.

The contribution of *e-Motion* to sFly focuses on autonomous cooperative localization and mapping in open and dynamic environments. It started on 01/01/09. For the moment, Alessandro Renzaglia (PhD student) and Agostino Martinelli work on this project. A new Postdoc will be recruited for the project as well quickly.

7.2.1.4. HAVEit project

Program: ICT-212154

Project acronym: HAVEit

Project title: Highly Automated Vehicles for Intelligent Transport

Duration: February 2008 - January 2011

Coordinator: F. Nashashibi and T. Fraichard

Abstract: HAVEit aims at the realization of the long-term vision of highly automated driving for intelligent transport. The project will develop, validate and demonstrate important intermediate steps towards highly automated driving.

HAVEit will significantly contribute to higher traffic safety and efficiency usage for passenger cars, buses and trucks, thereby strongly promoting safe and intelligent mobility of both people and goods. The significant HAVEit safety, efficiency and comfort impact will be generated by three measures:

- Design of the task repartition between the driver and co-driving system (ADAS) in the joint system.
- Failure tolerant safe vehicle architecture including advanced redundancy management.
- Development and validation of the next generation of ADAS directed towards higher level of automation as compared to the current state of the art.

The contribution of *e-Motion* to HAVEit focuses on safe driving.

7.2.2. Major European Organizations with which you have followed Collaborations

Department of Electrical & Computer Engineering: Univeristy of Thrace, Xanthi (GREECE)

Subject: 3D coverage based on Stochastic Optimization algorithms

BlueBotics: BlueBotics Company, Lausanne (Switzerland)

Subject: Implementation of self-calibration strategies for wheeled robots and SLAM algorithms for industrial purposes

Autonomous System laboratory: ETHZ, Zurich (Switzerland)

Subject: Vision and IMU data Fusion for 3D navigation in GPS denied environment.

7.3. International Initiatives

7.3.1. “ict-PAMM”

[September 2011- September 2013]

ict-PAMM is an ICT-ASIA project accepted in 2011 for 2 years. It is funded by the French Ministry of Foreign Affairs and INRIA. This project aims at conducting common research activities in the areas of robotic mobile service and robotic assistance of human in different contexts of human life. French partners are INRIA-emotion from Grenoble, INRIA-IMARA from Rocquencourt and Institut Blaise Pascal from Clermont-Ferrand. Asian Partners are IRA-Lab from Taiwan, ISRC-SKKU from Suwon in Korea, ITS-Lab from Kumamoto in Japan and Mica Institute from Hanoi in Vietnam.

7.3.2. “Predimap”

[September 2011- September 2013]

Predimap is an ICT-ASIA project accepted in 2011 for 2 years. It is funded by the French Ministry of Foreign Affairs and INRIA. This project aims at conducting common research activities in the area of perception in road environment. The main objective is the simultaneous use of local perception and Geographical Information Systems (GIS) in order to reach a global improvement in understanding road environment. Thus the research topics included in the project are: local perception, precise localization, map-matching and understanding of the traffic scenes. French partners are Inria-emotion from Grenoble, Heudiasyc team from CNRS/UTC, and Matis team from IGN. Foreign partners are Peking University and Shanghai Jiao Tong University in China, CSIS lab from Tokyo University in Japan and AIT Geoinformatics Center in Thailand.

7.3.3. “PRETIV”

[November 2011- October 2014]

Multimodal Perception and REasoning for Transnational Intelligent Vehicles" (PRETIV) is a three-year ANR project accepted in the framework of the Blanc International II Programme with participants from France (e-Motion of INRIA, Heudiasyc of CNRS, PSA Peugeot Citroen DRIA in Velizy) and China (Peking University, PSA Peugeot Citroen Technical Center in Shanghai). The project aims at developing of an online multimodal perception system for a vehicle and offline reasoning methods, dealing with incompleteness and uncertainties in the models and sensor data, as well as at conducting experiments in typical traffic scenarios in France and China to create an open comparative dataset for traffic scene understanding. The perception system will incorporate vehicle localization, mapping of static environmental objects, detecting and tracking of dynamic objects in probabilistic frameworks through multimodal sensing data and knowledge fusion. The reasoning methods are based on sensor data to learn semantics, activity and interaction patterns (vehicle - other objects, vehicle - infrastructure) to be used as a priori information to devise effective online perception algorithms toward situation awareness. The comparative dataset will contain experimental data of typical traffic scenarios with ground-truth, which will be used to learn country-specific traffic semantics and it will be open to the public.

7.3.4. Visits of International Scientists

John-David Yoder from Ohio Northern University visited us 12 months.

7.3.4.1. Internship

Procopio Stein, PhD at LAR (Laboratório de Automação e Robótica) at UA (Universidade de Aveiro) is in our team for november 2011 to april 2012.

7.3.5. Participation In International Programs

Submission of a international program with Taiwan called I-Rice. Partners for this proposition of an international center are IRA-lab (Taiwan university), LAAS, INRIA and UPMC. Topics are related to Cognitive Systems and Robotics. Project under evaluation (hearing step).

Submission of an ANR Blanc GeoProb in collaboration with the spinoff Probayes (Mexico). Project on complementary list.

8. Dissemination

8.1. Animation of the scientific community

A. Spalanzani and C. Laugier organised the french-mexican summer school on robotics and vision (SSIR'11). C. Laugier organised a workshop on intelligent vehicles during IROS'11. C. Laugier was co-chair of the IEEE-RAS Technical committee on "Autonomous ground vehicle and ITS" C. Laugier was member of the Advisory/Steering Committee of IEEE/RSJ IROS 2011. C. Laugier was Editor at IEEE ICRA conference Editorial Board (CEB). C. Laugier is program co-chair at IEEE/RSJ IROS 2012. A. Martinelli was Associate editor of ICRA 2011 and IROS 2011.

8.2. Teaching

Master : "autonomous Robotics", C. Laugier (responsible), A. Martinelli, M. Perrollaz, A. Nègre, 24h, M2, MOSIG-INP, France

Master (CNAM) : "autonomous Robotics", CNAM, France

Doctorat (école d'été): "autonomous Robotics", C. Laugier, 6h, SSIR'11.

Doctorat (école d'été): "Filtering, Localization and Mapping", A. Martinelli, 4h, SSIR'11.

PhD & HdR:

PhD in progress: Alessandro Renzaglia, 3D coverage by using stochastic approach, 2009, A. Martinelli.

PhD in progress: Chiara Troiani, vision and inertial sensor fusion for 3D navigation, 2011, A. Martinelli.

PhD in progress: Jorge Rios-Martinez, Comfortable navigation using social conventions, 2009, A. Spalanzani.

PhD in progress: Arturo Escobedo, Shared Control navigation, 2011, A. Spalanzani.

PhD in progress: Raphael Laurent, Bayesian modelling to implement and compare different theories of speech communication, 2011, P. Bessière.

PhD in progress: Stéphanie Lefèvre, context-aware bayesian filtering for collision prediction at roads intersections, 2009, C. Laugier

PhD in progress: Gabriel Synnaeve, Bayesian programming applied to a multi-player video games P. Bessière.

9. Bibliography

Major publications by the team in recent years

- [1] C. COUÉ, C. PRADALIER, C. LAUGIER, T. FRAICHARD, P. BESSIÈRE. *Bayesian Occupancy Filtering for Multi-Target Tracking: an Automotive Application*, in "Int. Journal of Robotics Research", January 2006, vol. 25, n^o 1, p. 19–30.
- [2] C. LAUGIER, I. PAROMTCHIK, M. PERROLLAZ, Y. MAO, J.-D. YODER, C. TAY, K. MEKHNACHA, A. NÈGRE. *Probabilistic Analysis of Dynamic Scenes and Collision Risk Assessment to Improve Driving Safety*, in "Intelligent Transportation Systems Magazine", November 2011, vol. 3, n^o 4, <http://hal.inria.fr/hal-00645046/en/>.
- [3] A. MARTINELLI. *The Odometry Error of a Mobile Robot With a Synchronous Drive System*, in "Transaction on Robotics and Automation", 2002, vol. 18, n^o 3, p. 399-405.
- [4] A. MARTINELLI. *State Estimation based on the Concept of Continuous Symmetry and Observability Analysis: The Case of Calibration*, in "IEEE Transactions on Robotics", May 2011, 000000, <http://hal.inria.fr/hal-00578795/en>.
- [5] G. VASQUEZ, A. DIZAN, T. FRAICHARD, C. LAUGIER. *Growing Hidden Markov Models: An Incremental Tool for Learning and Predicting Human and Vehicle Motion*, in "International Journal of Robotics Research", 2009, vol. 28, n^o 11-12, p. 1486-1506, <http://hal.inria.fr/inria-00430582/en/>.
- [6] G. VASQUEZ, A. DIZAN, T. FRAICHARD, C. LAUGIER. *Incremental Learning of Statistical Motion Patterns with Growing Hidden Markov Models*, in "IEEE Transactions on Intelligent Transportation Systems", 2009, <http://hal.inria.fr/inria-00379444/en/>.

Publications of the year

Articles in International Peer-Reviewed Journal

- [7] R. HORAUD, F. FORBES, M. YGUEL, G. DEWAELE, J. ZHANG. *Rigid and Articulated Point Registration with Expectation Conditional Maximization*, in "IEEE Transactions on Pattern Analysis and Machine Intelligence", March 2011, vol. 33, n^o 3, p. 587–602 [DOI : 10.1109/TPAMI.2010.94], <http://hal.inria.fr/inria-00590265/en>.

- [8] C. LAUGIER, I. PAROMTCHIK, M. PERROLLAZ, Y. MAO, J.-D. YODER, C. TAY, K. MEKHNACHA, A. NÈGRE. *Probabilistic Analysis of Dynamic Scenes and Collision Risk Assessment to Improve Driving Safety*, in "Intelligent Transportation Systems Magazine", November 2011, vol. 3, n^o 4, <http://hal.inria.fr/hal-00645046/en/>.
- [9] A. MARTINELLI. *State Estimation based on the Concept of Continuous Symmetry and Observability Analysis: The Case of Calibration*, in "IEEE Transactions on Robotics", May 2011, 000000, <http://hal.inria.fr/hal-00578795/en>.

International Conferences with Proceedings

- [10] L. DOITSIDIS, A. RENZAGLIA, S. WEISS, E. KOSMATOPOULOS, D. SCARAMUZZA, R. SIEGWART. *3D Surveillance Coverage Using Maps Extracted by a Monocular SLAM Algorithm*, in "IEEE International Conference on Robotics and Intelligent System (IROS)", San Francisco, États-Unis, September 2011, <http://hal.inria.fr/inria-00625534/en/>.
- [11] K. LAURENT, A. MARTINELLI, S. WEISS, D. SCARAMUZZA, R. SIEGWART. *Closed-Form Solution for Absolute Scale Velocity Determination Combining Inertial Measurements and a Single Feature Correspondence*, in "International Conference on Robotics and Automation", Shanghai, China, May 2011, <http://hal.inria.fr/hal-00641772/en>.
- [12] S. LEFÈVRE, J. IBANEZ-GUZMAN, C. LAUGIER. *Context-based Estimation of Driver Intent at Road Intersections*, in "2011 IEEE Symposium on Computational Intelligence in Vehicles and Transportation Systems", Paris, France, 2011, <http://hal.inria.fr/inria-00582343/en>.
- [13] S. LEFÈVRE, C. LAUGIER, I.-G. JAVIER. *Exploiting Map Information for Driver Intention Estimation at Road Intersections*, in "2011 IEEE Intelligent Vehicle Symposium", Baden-Baden, Germany, 2011, <http://hal.inria.fr/inria-00588743/en>.
- [14] A. MARTINELLI. *Closed-Form Solution for Attitude and Speed Determination by Fusing Monocular Vision and Inertial Sensor Measurements*, in "International Conference on Robotics and Automation, ICRA2011", China, January 2011, 999, <http://hal.inria.fr/hal-00568638/en>.
- [15] A. MARTINELLI, C. TROIANI, A. RENZAGLIA. *Vision-Aided Inertial Navigation: Closed-Form Determination of Absolute Scale, Speed and Attitude*, in "International Conference on Intelligent Robots and Systems", San Francisco, United States, 2011, <http://hal.inria.fr/hal-00641050/en>.
- [16] I. PAROMTCHIK, M. PERROLLAZ, C. LAUGIER. *Fusion of Telemetric and Visual Data from Road Scenes with a Lexus Experimental Platform*, in "IEEE International Symposium on Intelligent Vehicles", Baden-baden, Germany, June 2011, <http://hal.inria.fr/inria-00635779/en>.
- [17] A. RENZAGLIA, L. DOITSIDIS, A. MARTINELLI, E. KOSMATOPOULOS. *Adaptive-based Distributed Cooperative Multi-Robot Coverage*, in "American Control Conference 2011", San Francisco, United States, July 2011, <http://hal.inria.fr/inria-00607085/en>.
- [18] J. RIOS-MARTINEZ, C. LAUGIER, A. SPALANZANI. *Understanding human interaction for probabilistic autonomous navigation using Risk-RRT approach*, in "IEEE/RSJ International Conference on Intelligent Robots and Systems", San Francisco, United States, September 2011, <http://hal.inria.fr/inria-00633896/en>.

- [19] G. SYNNAEVE, P. BESSIÈRE. *A Bayesian Model for Opening Prediction in RTS Games with Application to StarCraft*, in "Proceedings of 2011 IEEE CIG", Seoul, Corée, République De, September 2011, <http://hal.archives-ouvertes.fr/hal-00607277/en/>.
- [20] G. SYNNAEVE, P. BESSIÈRE. *A Bayesian Model for Plan Recognition in RTS Games applied to StarCraft*, in "Proceedings of the Seventh Artificial Intelligence and Interactive Digital Entertainment Conference (AIIDE 2011)", Palo Alto, États-Unis, AAAI (editor), Proceedings of AIIDE, October 2011, p. 79–84, 7 pages, <http://hal.archives-ouvertes.fr/hal-00641323/en/>.
- [21] G. SYNNAEVE, P. BESSIÈRE. *A Bayesian Model for RTS Units Control applied to StarCraft*, in "Proceedings of IEEE CIG 2011", Seoul, Corée, République De, September 2011, <http://hal.archives-ouvertes.fr/hal-00607281/en/>.
- [22] G. SYNNAEVE, K. INOUE, A. DONCESCU, H. NABESHIMA, Y. KAMEYA, M. ISHIHATA, T. SATO. *Kinetic Models and Qualitative Abstraction for Relational Learning in Systems Biology*, in "BIOSTEC Bioinformatics 2011", Rome, Italie, January 2011, <http://hal.archives-ouvertes.fr/hal-00607296/en/>.

Conferences without Proceedings

- [23] S. ARIAS, J. LAHERA-PEREZ, A. NÈGRE, N. TURRO. *Evolution of the robotic control frameworks at INRIA Rhône-Alpes*, in "6th National Conference on Control Architectures of Robots", Grenoble, France, INRIA Grenoble Rhône-Alpes, May 2011, 8, <http://hal.inria.fr/inria-00599596/en>.
- [24] S. DHOUIB, N. DU LAC, J.-L. FARGES, S. GERARD, M. HEMAÏSSIA-JEANNIN, J. LAHERA-PEREZ, S. MILLET, B. PATIN, S. STINCKWICH. *Control Architecture Concepts and Properties of an Ontology Devoted to Exchanges in Mobile Robotics*, in "6th National Conference on Control Architectures of Robots", Grenoble, France, INRIA Grenoble Rhône-Alpes, May 2011, 24, <http://hal.inria.fr/inria-00599694/en>.

Scientific Books (or Scientific Book chapters)

- [25] G. VASQUEZ, A. DIZAN, T. FRAICHARD, C. LAUGIER. *Incremental Learning of Statistical Motion Patterns with Growing Hidden Markov Models*, in "Robotics Research", M. KANEKO, Y. NAKAMURA (editors), Springer Tracts in Advanced Robotics Series, Springer, 2011, vol. 66 [DOI : 10.1007/978-3-642-14743-2], <http://hal.inria.fr/inria-00584320/en>.

Research Reports

- [26] R. BARAVALLE, A. NÈGRE. *3D Mapping of indoor environments with a time of flight camera*, INRIA, May 2011, n^o RT-0406, <http://hal.inria.fr/inria-00594908/en>.
- [27] S. LEFÈVRE, C. LAUGIER, I.-G. JAVIER, P. BESSIÈRE. *Modelling Dynamic Scenes at Unsignalised Road Intersections*, INRIA, April 2011, n^o RR-7604, <http://hal.inria.fr/inria-00588758/en>.
- [28] A. MAKRIS, M. PERROLLAZ, I. PAROMTCHIK, C. LAUGIER. *Integration of visual and depth information for vehicle detection*, INRIA, August 2011, n^o RR-7703, <http://hal.inria.fr/inria-00613316/en>.
- [29] A. MARTINELLI. *Closed-Form Solutions for Attitude, Speed, Absolute Scale and Bias Determination by Fusing Vision and Inertial Measurements*, INRIA, January 2011, n^o RR-7530, <http://hal.inria.fr/inria-00569083/en>.

- [30] M. PERROLLAZ, J.-D. YODER, A. NÈGRE, A. SPALANZANI, C. LAUGIER. *A visibility-based approach for occupancy grid computation in disparity space*, INRIA, December 2011, n^o RR-7841, <http://hal.inria.fr/hal-00652591/en/>.

References in notes

- [31] D. E. ANGELAKI, A. G. SHAIKH, A. M. GREEN, J. D. DICKMAN. *Neurons compute internal models of the physical laws of motion*, in "Nature", 2004, vol. 430, p. 560–564.
- [32] M. AWAIS, K. MIKOLAJCZYK. *Feature Pairs Connected by Lines for Object Recognition*, in "Proc. of the Int. Conf. on Pattern Recognition (ICPR)", 2010, p. 3093-3096 [DOI : 10.1109/ICPR.2010.757].
- [33] P. BESSIÈRE. *Probability as an Alternative to Logic for Rational SensoryMotor Reasoning and Decision*, in "Probabilistic Reasoning and Decision Making in Sensory-Motor Systems", springer, 2008, p. 3–18, <http://hal.archives-ouvertes.fr/hal-00338708/en/>.
- [34] P. BESSIÈRE, C. LAUGIER, R. SIEGWART. *Probabilistic Reasoning and Decision Making in Sensory-Motor Systems*, springer, 2008, <http://hal.archives-ouvertes.fr/hal-00338704/en/>.
- [35] M. BRYSON, S. SUKKARIEH. *Observability Analysis and Active Control for Airbone SLAM*, in "IEEE Transaction on Aerospace and Electronic Systems", 2008, vol. 44, n^o 1, p. 261–280.
- [36] C. CAVALCANTE KOIKE, P. BESSIÈRE, E. MAZER. *Bayesian Approach to Action Selection and Attention Focusing*, in "Probabilistic Reasoning and Decision Making in Sensory-Motor Systems", springer, 2008, p. 177–201, <http://hal.archives-ouvertes.fr/hal-00338727/en/>.
- [37] F. COLAS, P. BESSIÈRE, J. DROULEZ, M. WEXLER. *Bayesian Modelling of Perception of Structure from Motion*, in "Probabilistic Reasoning and Decision Making in Sensory-Motor Systems", springer, 2008, p. 301–328, <http://hal.archives-ouvertes.fr/hal-00338732/en/>.
- [38] V. CORNILLEAU-PERES, J. DROULEZ. *The visual perception of three-dimensional shape from self-motion and object-motion*, in "Vision research", 1994, vol. 34, p. 2331–2336.
- [39] J. CORTÉS, S. MARTÍNEZ, T. KARATAS, F. BULLO. *Coverage Control for Mobile Sensing Networks*, in "IEEE Transactions on Robotics and Automation", 2004, vol. 20, n^o 2, p. 243–255.
- [40] C. COUÉ, C. PRADALIER, C. LAUGIER, T. FRAICHARD, P. BESSIÈRE. *Bayesian Occupancy Filtering for Multitarget Tracking: an Automotive Application*, in "Int. Journal of Robotics Research", 01 2006, vol. 25, p. 19–30, <http://hal.inria.fr/inria-00182004/en/>.
- [41] E. DERESZYNSKI, J. HOSTETLER, A. FERN, T. D. T.-T. HOANG, M. UDARBE. *Learning Probabilistic Behavior Models in Real-Time Strategy Games*, in "Artificial Intelligence and Interactive Digital Entertainment (AIIDE)", AAAI (editor), 2011.
- [42] J. DIARD, P. BESSIÈRE. *Bayesian Maps: Probabilistic and Hierarchical Models for Mobile Robot Navigation*, in "Probabilistic Reasoning and Decision Making in Sensory-Motor Systems", springer, 2008, p. 153–175, <http://hal.archives-ouvertes.fr/hal-00338724/en/>.

- [43] K. DOKKA, P. R. MACNEILAGE, G. C. DE ANGELIS, D. E. ANGELAKI. *Estimating distance during self-motion: a role for visual-vestibular interactions*, in "J. of Vision", 2011, vol. 11, p. 1–16.
- [44] P. DOLLÁR, C. WOJEK, B. SCHIELE, P. PERONA. *Pedestrian detection: A benchmark*, in "CVPR", 2009, p. 304-311.
- [45] P. F. FELZENSZWALB, R. B. GIRSHICK, D. A. MCALLESTER, D. RAMANAN. *Object Detection with Discriminatively Trained Part-Based Models*, in "IEEE Trans. Pattern Anal. Mach. Intell.", 2010, vol. 32, n^o 9, p. 1627-1645.
- [46] D. FOX, W. BURGARD, S. THRUN. *The dynamic window approach to collision avoidance*, in "IEEE Robotics & Automation Magazine", March 1997, vol. 4, n^o 1, p. 23–33 [DOI : 10.1109/100.580977], <http://ieeexplore.ieee.org/lpdocs/epic03/wrapper.htm?arnumber=580977>.
- [47] C. FULGENZI. *Navigation autonome en environnement dynamique utilisant des modèles probabilistes de perception et de prédiction du risque de collision.*, Institut National Polytechnique de Grenoble - INPG, 06 2009, <http://tel.archives-ouvertes.fr/tel-00398055/en/>.
- [48] C. FULGENZI, A. SPALANZANI, C. LAUGIER. *Probabilistic motion planning among moving obstacles following typical motion patterns.*, in "IEEE/RSJ International Conference on Intelligent Robots and Systems", États-Unis St. Louis, Missouri, 2009, <http://hal.inria.fr/inria-00398059/en>.
- [49] C. FULGENZI, C. TAY, A. SPALANZANI, C. LAUGIER. *Probabilistic navigation in dynamic environment using Rapidly-exploring Random Trees and Gaussian Processes*, in "IEEE/RSJ 2008 International Conference on Intelligent Robots and Systems", France Nice, 2008, <http://hal.inria.fr/inria-00332595/en/>.
- [50] C. FULGENZI, A. SPALANZANI, C. LAUGIER, C. TAY. *Risk based motion planning and navigation in uncertain dynamic environment*, INRIA, 10 2010, <http://hal.inria.fr/inria-00526601/PDF/PPRRT.pdf>.
- [51] D. GERÓNIMO, A. M. LÓPEZ, A. D. SAPPA, T. GRAF. *Survey of Pedestrian Detection for Advanced Driver Assistance Systems*, in "IEEE Trans. Pattern Anal. Mach. Intell.", 2010, vol. 32, n^o 7, p. 1239-1258.
- [52] G. GRISETTI, C. STACHNISS, W. BURGARD. *Improved techniques for grid mapping with rao-blackwellized particle filters*, in "IEEE Transactions on Robotics", 2007, vol. 23, n^o 1, p. 34–46, http://ieeexplore.ieee.org/xpls/abs_all.jsp?arnumber=4084563.
- [53] E. T. HALL. *The hidden Dimension: Man's Use of Space in Public and Private*, The Bodley Head Ltd, London, UK, 1966.
- [54] E. JONES, S. SOATTO. *Visual-inertial navigation, mapping and localization: A scalable real-time causal approach*, in "The International Journal of Robotics Research", 2011, vol. 30, n^o 4, p. 407–430.
- [55] F. KABANZA, P. BELLEFEUILLE, F. BISSON, A. R. BENASKEUR, H. IRANDOUST. *Opponent Behaviour Recognition for Real-Time Strategy Games*, 2010, <http://aaai.org/ocs/index.php/WS/AAAIW10/paper/view/2024>.
- [56] J. KELLY, G. SUKHATME. *Visual-inertial simultaneous localization, mapping and sensor-to-sensor self-calibration*, in "Int. Journal of Robotics Research", 2011, vol. 30, n^o 1, p. 56–79.

- [57] A. KENDON. *Spacing and Orientation in Co-present Interaction*, in "Development of Multimodal Interfaces: Active Listening and Synchrony", A. ESPOSITO, N. CAMPBELL, C. VOGEL, A. HUSSAIN, A. NIJHOLT (editors), Lecture Notes in Computer Science, Springer Berlin / Heidelberg, 2010, vol. 5967, p. 1-15.
- [58] E. B. KOSMATOPOULOS, L. DOITSIDIS, K. ABOUDOLAS. *A Unified Methodology for Multi-Robot Passive and Active Sensing*, in "17th IEEE Mediterranean Conference on Control and Automation", Thessaloniki, 2009.
- [59] E. B. KOSMATOPOULOS. *An adaptive optimization scheme with satisfactory transient performance*, in "Automatica", 2009, vol. 45, n^o 3, p. 716–723.
- [60] S. M. LAVALLE. *Planning Algorithms*, Cambridge University Press, 2006.
- [61] R. LE HY. *Programmation et apprentissage bayésien de comportements pour personnages synthétiques – application aux personnages de jeux vidéos*, Institut National Polytechnique de Grenoble - INPG, April 2007, <http://tel.archives-ouvertes.fr/tel-00366235/en/>.
- [62] R. LE HY, P. BESSIÈRE. *Playing to Train Your Video Game Avatar*, in "Probabilistic Reasoning and Decision Making in Sensory-Motor Systems", springer, 2008, p. 263–276, <http://hal.archives-ouvertes.fr/hal-00338729/en/>.
- [63] O. LEBELTEL, P. BESSIÈRE. *Basic Concepts of Bayesian Programming*, in "Probabilistic Reasoning and Decision Making in Sensory-Motor Systems", springer, 2008, p. 19–48, <http://hal.archives-ouvertes.fr/hal-00338715/en/>.
- [64] B. LEIBE, A. LEONARDIS, B. SCHIELE. *Robust Object Detection with Interleaved Categorization and Segmentation*, in "Int. J. of Computer Vision", 2008, vol. 77, n^o 1-3, p. 259-289.
- [65] H. C. LONGUET-HIGGINS, K. PRAZDNY. *The interpretation of a moving retinal image*, in "Royal Society of London B: Biological Sciences", 1980, vol. 208, p. 385–397.
- [66] P. R. MACNEILAGE, M. S. BANKS, G. C. DE ANGELIS, D. E. ANGELAKI. *Vestibular heading discrimination and sensitivity to linear acceleration in head and world coordinates*, in "J. of Neuroscience", 2010, vol. 30, p. 9084–9094.
- [67] P. R. MACNEILAGE, N. GANESAN, D. E. ANGELAKI. *Computational Approaches to Spatial Orientation: From Transfer Functions to Dynamic Bayesian Inference*, in "J Neurophysiol", 2008, vol. 100, p. 2981–2996.
- [68] A. R. MANISH META. *Meta-Level Behavior Adaptation in Real-Time Strategy Games*, in "ICCB-10 Workshop on Case-Based Reasoning for Computer Games, Alessandria, Italy", 2010.
- [69] A. MARTINELLI. *Local Decomposition and Observability Properties for Automatic Calibration in Mobile Robotics*, in "Icra", Japan Kobe, 2009, <http://hal.inria.fr/inria-00359939/en/>.
- [70] A. MARTINELLI. *Using the Distribution Theory to Simultaneously Calibrate the Sensors of a Mobile Robot.*, in "RSS", Canada, 2009, <http://hal.archives-ouvertes.fr/hal-00428646/en/>.

- [71] A. MARTINELLI. *Using the Distribution Theory to Simultaneously Calibrate the Sensors of a Mobile Robot*, INRIA, 2009, n^o RR-6796, <http://hal.inria.fr/inria-00353079/PDF/RR-6796.pdf>.
- [72] A. MARTINELLI. *Continuous Symmetries and Observability Properties in Autonomous Navigation*, INRIA, 2010, n^o RR-7049, <http://hal.inria.fr/inria-00421233/PDF/RR-7049V2.pdf>.
- [73] K. MEKHNACHA, Y. MAO, D. RAULO, C. LAUGIER. *Bayesian occupancy filter based 'Fast Clustering-Tracking' algorithm*, in "IEEE/RSJ 2008 International Conference on Intelligent Robots and Systems", France Nice, 2008, <http://hal.inria.fr/inria-00336356/en/>.
- [74] K. MEKHNACHA, P. BESSIÈRE. *BCAD: A Bayesian CAD System for Geometric Problems Specification and Resolution*, in "Probabilistic Reasoning and Decision Making in Sensory-Motor Systems", springer, 2008, p. 205–231, <http://hal.archives-ouvertes.fr/hal-00338728/en/>.
- [75] D. M. MERFELD, L. ZUPAN, R. J. PETERKA. *Humans use internal models to estimate gravity and linear acceleration*, in "Nature", 1999, vol. 398, p. 615–618.
- [76] K. MISHRA, S. ONTAÑÓN, A. RAM. *Situation Assessment for Plan Retrieval in Real-Time Strategy Games*, in "ECCBR", 2008, p. 355-369.
- [77] A. MOURIKIS, N. TRAWNY, S. ROUMELIOTIS, A. JOHNSON, A. ANSAR, L. MATTHIES. *Vision-Aided Inertial Navigation for Spacecraft Entry, Descent, and Landing*, in "Transactions on Robotics", 2009, vol. 25, n^o 2, p. 264–280.
- [78] I. PAROMTCHIK, C. LAUGIER, M. PERROLLAZ, Y. MAO, A. NÈGRE, C. TAY. *The ArosDyn Project: Robust Analysis of Dynamic Scenes*, in "International Conference on Control, Automation, Robotics and Vision", Singapore Singapour, December 2010, <http://hal.inria.fr/inria-00539999/en>.
- [79] M. PERROLLAZ, A. SPALANZANI, D. AUBERT. *Probabilistic representation of the uncertainty of stereo-vision and application to obstacle detection*, in "Intelligent Vehicles Symposium", United States San Diego, 2010, <http://hal.inria.fr/inria-00493397/en>.
- [80] M. PERROLLAZ, J.-D. YODER, C. LAUGIER. *Using obstacles and road pixels in the disparity-space computation of stereo-vision based occupancy grids*, in "IEEE Intelligent Transportation Systems Conference", Portugal Madeira, September 2010, <http://hal.inria.fr/inria-00527777/en>.
- [81] M. PERROLLAZ, J.-D. YODER, A. SPALANZANI, C. LAUGIER. *Using the disparity space to compute occupancy grids from stereo-vision*, in "International Conference on Intelligent Robots and Systems (IROS)", Taiwan, Province Of China Taipei, October 2010, <http://hal.inria.fr/inria-00527785/en>.
- [82] C. PRADALIER, P. BESSIÈRE. *The CyCab : Bayesian Navigation on SensoryMotor Trajectories*, in "Probabilistic Reasoning and Decision Making in Sensory-Motor Systems", springer, 2008, p. 51–75, <http://hal.archives-ouvertes.fr/hal-00338720/en/>.
- [83] A. RENZAGLIA, L. DOITSIDIS, A. MARTINELLI, E. KOSMATOPOULOS. *Adaptive-based, Scalable Design for Autonomous Multi-Robot Surveillance*, in "49th IEEE Conference on Decision and Control (CDC)", Atlanta, États-Unis, December 2010, <http://hal.inria.fr/inria-00579310/en/>.

- [84] A. RENZAGLIA, A. MARTINELLI. *Distributed Coverage Control for a Multi-Robot Team in a Non-Convex Environment*, in "IEEE IROS09 3rd Workshop on Planning, Perception and Navigation for Intelligent Vehicles", États-Unis d'Amérique St. Louis, 2009, <http://hal.inria.fr/inria-00428075/en/>.
- [85] A. RENZAGLIA, L. DOITSIDIS, A. MARTINELLI, E. KOSMATOPOULOS. *Cognitive-based Adaptive Control for Cooperative Multi-Robot Coverage*, in "IEEE International Conference on Robotics and Intelligent System (IROS)", Taipei Taiwan, Province De Chine, 10 2010, http://hal.inria.fr/inria-00537808/PDF/cao_iros10.pdf.
- [86] M. ROHRBACH, M. ENZWEILER, D. M. GAVRILA. *High-Level Fusion of Depth and Intensity for Pedestrian Classification*, in "DAGM-Symposium", 2009, p. 101-110.
- [87] D. STRELOW, S. SINGH. *Motion estimation from image and inertial measurements*, in "International Journal of Robotics Research", 2004, vol. 23.
- [88] C. TAY, K. MEKHNACHA, C. CHEN, M. YGUEL, C. LAUGIER. *An Efficient Formulation of the Bayesian Occupation Filter for Target Tracking in Dynamic Environments*, in "International Journal Of Autonomous Vehicles", 2007, <http://hal.inria.fr/inria-00182089/en/>.
- [89] C. TAY, K. MEKHNACHA, M. YGUEL, C. COUÉ, C. PRADALIER, C. LAUGIER, T. FRAICHARD, P. BESSIÈRE. *The Bayesian Occupation Filter*, in "Probabilistic Reasoning and Decision Making in Sensory-Motor Systems", springer, 2008, p. 77–98, <http://hal.archives-ouvertes.fr/hal-00338721/en/>.
- [90] S. THRUN, W. BURGARD, D. FOX. *Probabilistic Robotics*, The MIT Press, 2005.
- [91] S. THRUN, W. BURGARD, D. FOX. *Probabilistic Robotics*, MIT Press, 2005, vol. 45, n^o 3.
- [92] B. G. WEBER, M. MATEAS. *A Data Mining Approach to Strategy Prediction*, in "CIG (IEEE)", 2009.
- [93] S. WEISS, D. SCARAMUZZA, R. SIEGWART. *Monocular-SLAM-Based Navigation for Autonomous Micro Helicopters in GPS-Denied Environments*, in "Journal of Field Robotics", 2011, vol. 28, n^o 6.
- [94] M. WEXLER, F. PANERAI, I. LAMOURET, J. DROULEZ. *Self-motion and perception of stationary objects*, in "Nature", 2001, vol. 409, p. 85–88.
- [95] L. H. ZUPAN, D. M. MERFELD, C. DARLOT. *Using sensory weighting to model the influence of canal, otolith and visual cues on spatial orientation and eye movements*, in "Biol. Cybern", 2002, vol. 86, p. 209–230.