



Activity Report 2013

## Team LOGNET

Logical Networks: Self-organizing Overlay  
Networks and Programmable Overlay  
Computing Systems

RESEARCH CENTER  
Sophia Antipolis - Méditerranée

THEME  
Distributed Systems and Services



## Table of contents

<b>1. Members</b>	<b>1</b>
<b>2. Overall Objectives</b>	<b>1</b>
2.1. LogNet's Motto and Logo and Manifesto	1
2.2. Highlights of the Year	2
<b>3. Research Program</b>	<b>4</b>
<b>4. Application Domains</b>	<b>4</b>
<b>5. Software and Platforms</b>	<b>5</b>
5.1. myMed	5
5.2. myMed backbone	5
5.3. myMed frontend	5
5.4. Synapse simulator in Oversim	6
5.5. Synapse model Erlang validator	6
5.6. CCN-TV Omnet++ simulator	6
5.7. Java implementation of the OGP protocol and the experiment controller	6
5.8. Java implementation of the Synapse protocol and the experiment controller	6
5.9. Reputation Computation Engine for Social Web Platforms	7
5.10. Ariwheels	7
5.11. Arigatoni simulator	7
5.12. Synapse client	8
5.13. Open Synapse client	8
5.14. Husky interpreter	10
5.15. myTransport Gui	10
5.16. myDistributed Catalog for Digitized Cultural Heritage	10
5.17. myStreaming P2P	12
<b>6. New Results</b>	<b>12</b>
6.1. A Backward-Compatible Protocol for Inter-routing over Heterogeneous Overlay Networks	12
6.2. Interconnection of large scale unstructured P2P networks: modeling and analysis	13
6.3. SIEVE: a distributed, accurate, and robust technique to identify malicious nodes in data dissemination on MANET	14
6.4. CCN-TV: a data-centric approach to real-time video services	14
6.5. Towards a Trust and Reputation Framework for Social Web Platforms and @-economy	14
6.6. A Scalable Communication Architecture for Advanced Metering Infrastructure	16
6.7. An Open Logical Framework	16
<b>7. Bilateral Contracts and Grants with Industry</b>	<b>18</b>
<b>8. Partnerships and Cooperations</b>	<b>18</b>
8.1. European Initiatives	18
8.2. International Initiatives	18
8.3. International Research Visitors	19
<b>9. Dissemination</b>	<b>19</b>
9.1. Scientific Animation	19
9.2. Teaching - Supervision - Juries	19
9.2.1. Teaching	19
9.2.2. Supervision	19
9.2.3. Juries	19
9.3. Popularization	19
<b>10. Bibliography</b>	<b>20</b>



## Team LOGNET

**Keywords:** Network Protocols, Peer-to-peer, Social Networks, Type Systems, Proof Theory

*This team is composed by one only permanent person for more than 4 years: We agree that configuration is not know as the classical “Inria” one but - as a matter of fact - there are other examples of Inria teams at Sophia Antipolis composed by a singleton that had better lifetime than LogNet (e.g. they where not closed because of this peculiarity).*

Creation of the Team: 2008 January 01, end of the Team: 2013 July 01.

## 1. Members

### Research Scientist

Luigi Liquori [Team leader, Inria, Senior Researcher, HdR]

### Engineers

Cyril Auburtin [Inria, Interreg Alcotra myMed, until Jan 2013]

Milo Casagrande [Inria, Interreg Alcotra myMed, until Mar 2013]

Romain Fritz [Inria, Interreg Alcotra myMed, until Mar 2013]

Valeria Mendolia [Inria, Interreg Alcotra myMed, until Apr 2013]

Elsa Rol [Inria, Interreg Alcotra myMed, from Jan 2013 until Mar 2013]

Salvatore Spoto [Inria, Interreg Alcotra myMed, until Mar 2013]

Bernardyna Stapor [Inria, Interreg Alcotra myMed, until Jan 2013]

### PhD Students

Riccardo Loti [Inria, co-advising University of Nice Sophia-Antipolis and University of Turin, until Mar 2014]

Giang Ngo Hoang [Inria, co-advising University of Nice Sophia-Antipolis and Hanoi University of Science and Technology, until Dec 2013]

Phuong Thao Nguyen [Inria, University of Nice Sophia-Antipolis, Bourse Président Unice, until Jan 2014]

Vincenzo Ciancaglini [Inria, co-advising University of Nice Sophia Antipolis and SAP, MESR, until Jul 2013]

Petar Maksimovic [Inria, co-advising University of Nice Sophia Antipolis and University of Novi-Sad, TEMPUS-BASILEUS grant, until Oct 2013]

### Visiting Scientist

Bruno Martin [University of Nice Sophia-Antipolis, until Jun 2013]

### Others

Nicolas Gauche [Inria, Internship, from Apr 2013 until Jun 2013]

Romain Guillot [Inria, Internship, from Apr 2013 until Jun 2013]

Benjamin Lissillour [Inria, Internship, from Apr 2013 until Jun 2013]

## 2. Overall Objectives

### 2.1. LogNet’s Motto and Logo and Manifesto

Our Motto is “*Computer is moving on the edge of the Network...*” by Jan Bosch, Nokia Labs, [LNCS 4415, 2007] and our logo is in Figure 1.

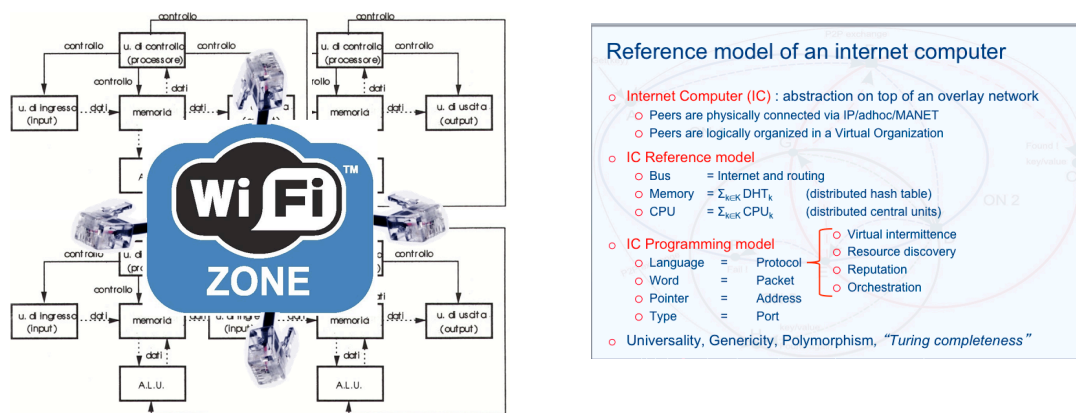

Figure 1. LogNet logo and Reference model of an "Internet Computer"

We propose foundations for generic overlay networks and overlay computing systems. Such overlays are built over a large number of distributed computational agents, virtually organized in colonies, and governed by a leader (broker) who is elected democratically (*vox populi, vox dei*) or imposed by system administrators (*primus inter pares*). Every agent asks the broker to log into the colony by declaring the resources that can be offered (with variable guarantees). Once logged in, an agent can ask the broker for other resources. Colonies can recursively be considered as evolved agents who can log into an outermost colony governed by another super-leader. Communications and routing intra-colonies goes through a broker-2-broker PKI-based negotiation. Every broker routes intra- and inter- service requests by filtering its resource routing table, and then forwarding the request firstly inside its colony, and secondly outside, via the proper super-leader (thus applying an endogenous-first-exogenous-last strategy). Theoretically, queries are formulas in first-order logic equipped with a small program used to orchestrate and synchronize atomic formulas (atomic services). When the client agent receives notification of all of (or part of) the requested resources, then the real resource exchange is performed directly by the server(s) agents, without any further mediation of the broker, in a pure peer-to-peer fashion. The proposed overlay promotes an intermittent participation in the colony, since peers can appear, disappear, and organize themselves dynamically. This implies that the routing process may lead to failures, because some agents have quit or are temporarily unavailable, or they were logged out manu militari by the broker due to their poor performance or greediness. We aim to design, validate through simulation, and implement these foundations in a generic overlay network computer system.

Therefore, the general objectives of LogNet can be summarized as follows:

- to provide adequate notions and definitions of a generic overlay computer: logic, communications, implementations, applications, hardware;
- on the basis of the above definitions, to propose a precise architecture of an overlay computer with related execution model and implement it, see Fig 1;
- on the basis of the above definitions, to implement useful applications suitable to help the logical and software assembling of an overlay computer and experiment it at large scale;
- putting our savoir-faire in logics, type theory, formal systems, object-oriented, functional programming to the service of telecommunications and the so-called Internet of the future.

## 2.2. Highlights of the Year

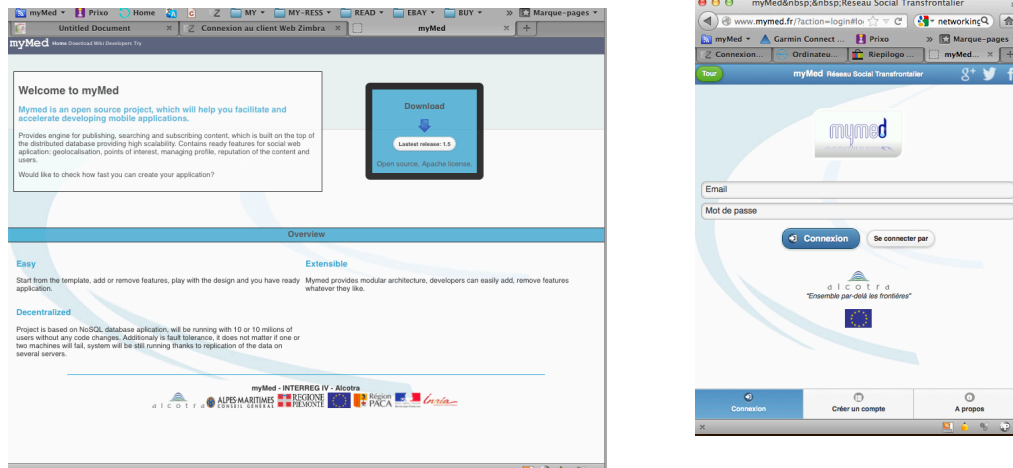

Figure 2. <http://www.mymed.fr>



Figure 3. Nice Matin

- The contrat Alcotra Interreg *myMed: a peer-to-peer programmable social network and cloud platform* 2010-2013 ends. LogNet was the head of this ambitious project. The project can be visited at the page <http://www.mymed.fr> Please have a try, see Fig 2 !
- Four articles on myMed has been published in the newspaper “Nice Matin”
  - <http://www.nicematin.com/article/lapplication-myriviera-lancement-en-fevrier.689848.html>
  - <http://www.nicematin.com/papier/tout-sur-la-riviera%E2%80%A6-a-portee-de-doigt.831703.html>
  - <http://www.nicematin.com/derniere-minute/myriviera-bientot-sur-les-smartphones.831394.html>
  - See Fig 3.
- A quite nice “artistic video” on myMed can be seen on [www-sop.inria.fr/teams/lognet/multimedia/myMed\\_v3.mov](http://www-sop.inria.fr/teams/lognet/multimedia/myMed_v3.mov). Please enjoy it!

## 3. Research Program

### 3.1. Introduction

We study overlay networks and peer-to-peer systems. Our skills are applied to studying protocols to interconnect heterogeneous networks, while guaranteeing backward compatibility. We experiment with those networks and systems in various fields, such as social networks and video streaming.

We design and implement a generic social platform, which is able to “program” and “run” (in a cloud based platform hosting a NoSQL data base) generic social networks. This is the first step towards a full decentralized P2P-based social network platform.

We also study Trust and Reputation Systems for P2P networks, and for Network Web Economy.

The final objective of those research veins is to move the computer and the computability at the edge of the network.

As another topic, we also study logics and type theory for improving proof assistants based on the Curry-Howard Isomorphism.

## 4. Application Domains

### 4.1. Applications

Because of its generality, our overlay network can target many applications. We would like to list a small number of useful programmable overlay-network-related case studies that can be considered as “LogNet Grand Challenges”, to help potential readers understand the interest of our research program.

- Interconnecting overlay networks transparently;
- building a programmable social network platform relying on a cloud + P2P architecture;
- experimenting with our interconnecting algorithm in the domain of video streaming;
- studying and integrating mobile devices and mobile networks 3G/4G as a real peer in actual P2P systems;
- studying trust and reputation systems applied to P2P and web economy;
- studying new distributed models of computation (long term objective);
- studying new type theories and lambda-calculi to be the basis of new proof assistants based on Curry-Howard isomorphism.



## 5. Software and Platforms

### 5.1. myMed

Our flagship software is called myMed. myMed is a highly innovative project in which three main orthogonal components are brought together:

- a software development kit, SDKmyMed, with which we can build social networks in “rush time”;
- a novel distributed hosting cloud, CLOUDmyMed, with which the social applications (developed by us and by third parties) can be hosted and run;
- a pull of 5-10 social network applications, aka “sociapps” developed in our team to test the SDKmyMed.

The sociapp can be enjoyed in almost all platforms, from web browsers, to mobile web, until IOS and Android devices.

### 5.2. myMed backbone

**Participants:** Luigi Liquori [contact], The Mymed Engineer Team.

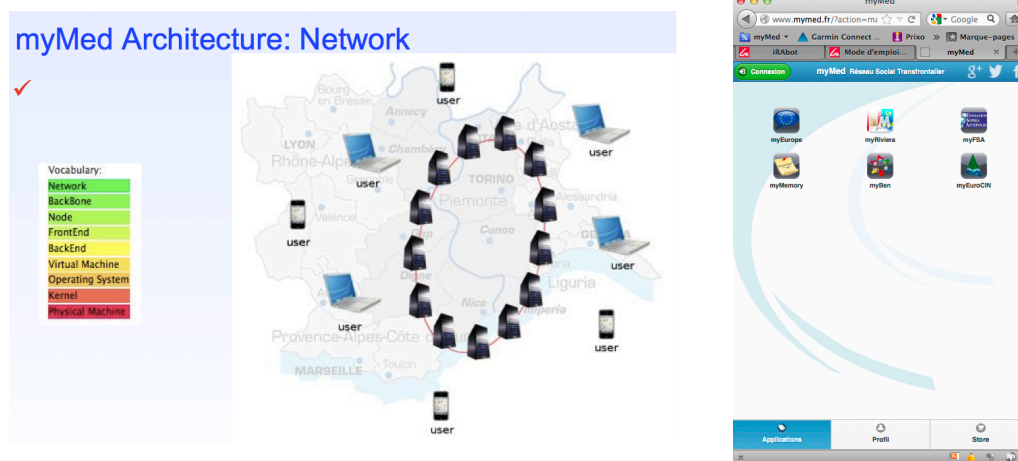

Figure 4. The myMed backbone and the myMed LaunchPad

We have implemented a “backbone” for the myMed social network using a nosql database called Cassandra <http://cassandra.apache.org>, the latter used also by social networks like Facebook and Twitter. The backbone relies on 50 PC quad code HP400, equipped with 2Tb of hard drive each.

### 5.3. myMed frontend

**Participants:** Luigi Liquori [contact], The Mymed Engineer Team.

We have implemented a front-end with which all the social application can be used and downloaded via a “store” mechanism similar to the ones of Apple and Google stores. Social applications can be chosen, voted for via a reputation system, and uninstalled (including all personal data) if the user wants. We have also implemented a “template” allowing to build “proofs-of-concept” of social networks in a very short time.

## 5.4. Synapse simulator in Oversim

**Participants:** Vincenzo Ciancaglini [contact], Luigi Liquori.

Synapse-Oversim is an implementation of the Synapse overlay interconnection protocol in the Oversim overlay simulator. The software presents two main contributions: first of all, a fork of the original Oversim simulator has been implemented in order to support running multiple protocol modules in a single instance of Oversim, a necessary feature in order to simulate a set of heterogeneous interconnected networks. Secondly, the whole Synapse protocol has been implemented on top of Oversim, in order to allow for the efficient inter-routing of messages between heterogeneous overlays. The Synapse code has been developed in C++, by running in Oversim, its correctness and its performances can be evaluated, while then the code can be easily ported to a real-world application.

## 5.5. Synapse model Erlang validator

**Participant:** Vincenzo Ciancaglini [contact].

During the work on the Synapse protocol, we devised a mathematical model which would allow us to estimate performance indexes of an interconnected system without having to deploy a full-scale experiment. In order to be validated, however, the model results needed to be verified against some simulation results, run under simplified conditions, but with the highest possible number of nodes. To achieve this, a dedicated simulator has been developed using Erlang, a programming language dedicated to parallel and distributed applications, which allow for the simulation of extreme systems, with a number of nodes beyond one million, in the fastest way achievable, by fully exploiting the multicore architecture of modern machines. The simulator instantiates a lightweight thread for each node, and the communication are rendered by message passing between the different node threads, thus keeping the simulation conditions as close as possible to a real world behavior.

## 5.6. CCN-TV Omnet++ simulator

**Participants:** Vincenzo Ciancaglini [contact], Riccardo Loti, Luigi Liquori.

CCN-TV-SIM is a software, based on the network simulation framework Omnet++, which simulates a real time video broadcast system over content-centric networks. The system is able to manage multiple streams of video at different rates, using real video traces, simulate different caching policies, different channels being transmitted concurrently, background network traffic, and different channel switch rates. Furthermore it can exploits network topologies taken from real networks, like the Deutsche Telecom network, or the Geant.

## 5.7. Java implementation of the OGP protocol and the experiment controller

**Participants:** Giang Ngo Hoang [contact], Luigi Liquori.

OGP-Experiment contains Java implementation of the OGP protocol (OGP stands for overlay gateway protocol) which is used for inter-routing between heterogeneous overlay networks, and a Java implementation of the experiment controller, which is responsible for scheduling, managing and monitoring the statistics of the experiments. The software supports experiments in churn and no-churn environments. Performance metrics of the OGP protocol, such as the latency, the successful rate of data lookup and the traffic generated by a peer are reported. The experiments are performed on the Grid 5000 platform. Heterogeneous overlays which are connected by OGP can be easily plugged into the software.

## 5.8. Java implementation of the Synapse protocol and the experiment controller

**Participants:** Hoang Giang Ngo [contact], Luigi Liquori.

Synapse-Experiment contains Java implementation of the Synapse overlay interconnection protocol and Java implementation of the experiment controller which is responsible for scheduling, managing and monitoring the statistics of the experiments. The software supports experiments in churn and no-churn environments. Performance metrics of the Synapse protocol, such as the latency, the successful rate of data looking up and the traffic generated by a peer are reported. The experiments are performed on the Grid 5000 platform.

## 5.9. Reputation Computation Engine for Social Web Platforms

**Participant:** Thao Nguyen [contact].

Among the three components of a Trust and Reputation System, information gathering is most dependent on the application system, followed by the decision support component and then by the building of a robust Reputation Computation Engine and an experimental GUI, showing how bad users are segregated by the engine. To simulate the working of the reputation engine, we set up a population of  $N_u$  users, providing the same service, and undertaking  $N_t$  transactions. In each transaction, a random consumer is assigned to request the service. Other users will then be candidate providers for this request. When a user plays the role of a consumer, his behavior is modeled in the `raterType` attribute. Three types of raters include HONEST, DISHONEST and COLLUSIVE. HONEST raters share their personal experience honestly, i.e.  $R_r = E_p$ . DISHONEST raters provide ratings 0:5 different from their true estimation, i.e.  $R_r = E_p \pm 0:5$ . COLLUSIVE raters give the highest ratings ( $R_r = 1$ ) to users in their collusion and the lowest ratings ( $R_r = 0$ ) to the rest. Similarly, when a user acts as a provider, he can be one of the following types of providers: GOOD, NORMAL, BAD, or GOODTURNBAD. This type is denoted in `providerType` attribute. The QoS of the service provided by a BAD, NORMAL, or GOOD provider has a value in the interval  $(0; 0:4]$ ,  $(0:4; 0:7]$ , or  $(0:7; 1]$  respectively. A GOODTURNBAD provider will change the QoS of his service when 50% of  $N_t$  transactions have been done in the simulation. To get a transaction done, a consumer obtains a list of providers, computes reputation scores for them, chooses a provider to perform the transaction, updates his private information, and publishes his rating for the provider. The quality of service that the consumer will experience depends on the `providerType` of the chosen provider. The difference between the consumer's rating for the provider and his observation depends on the consumer's `raterType`.

To run a simulation, the user must specify 10 parameters as described above: Simulation( $N_u$ ,  $N_t$ , %G, %N, %B, %GTB, %H, %D, %C, %dataLost). The simulator has been published in [22].

In 2013, the simulator has been improved and made more robust: it would one of the output of the Ph.D. work of Thao Nguyen whose defense is envisaged in the first half of 2014.

## 5.10. Ariwheels

**Participants:** Luigi Liquori [contact for the *Ariwheels* simulator], Claudio Casetti [Politecnico di Torino, Italy], Diego Borsetti [Politecnico di Torino, Italy], Carla-Fabiana Chiasserini [Politecnico di Torino, Italy], Diego Malandrino [Politecnico di Torino, Italy, contact for the *Ariwheels* client].

*Ariwheels* is an info-mobility solution for urban environments, with access points deployed at both bus stops (forming thus a wired backbone) and inside the buses themselves. Such a network is meant to provide connectivity and services to the users of the public transport system, allowing them to exchange services, resources and information through their mobile devices. *Ariwheels* is both:

- a protocol, based on *Arigatoni* and the publish/subscribe paradigm;
- a set of applications, implementing the protocol on the different types of nodes;
- a simulator, written in OMNET++ and recently ported to the ns2 simulator, see Fig 6.

See the web page <http://www-sop.inria.fr/members/Luigi.Liquori/ARIGATONI/Ariwheels.htm> and <http://arigt.altervista.org>.

## 5.11. Arigatoni simulator

**Participants:** Luigi Liquori [contact], Raphael Chand [Université de Geneva, Switzerland].

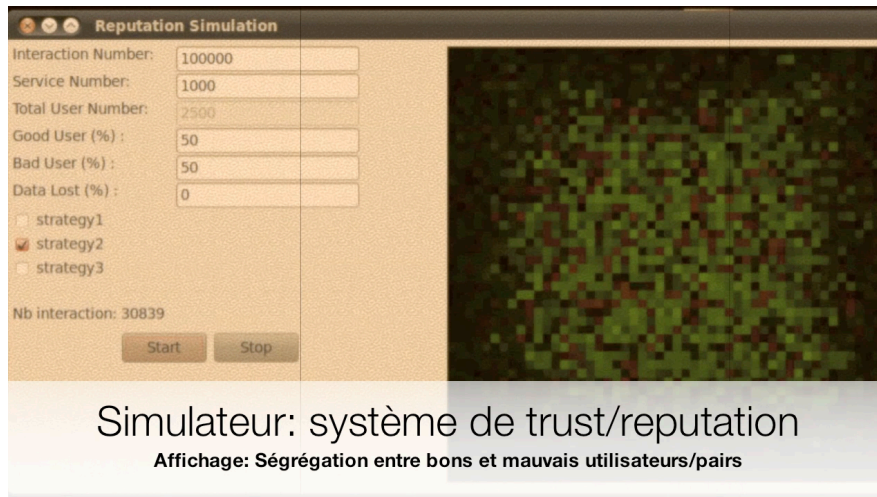

Figure 5. A prototype graphical GUI for the Reputation Computation Engine

We have implemented in C++ (~2.5K lines of code) the Resource Discovery Algorithm and the Virtual Intermittent Protocol of the Arigatoni Overlay Network. The simulator was used to measure the load when we issued  $n$  service requests at Global Computers chosen uniformly at random. Each request contained a certain number of instances of one service, also chosen uniformly at random. Each service request was then handled by the Resource Discovery mechanism of Arigatoni networks.

## 5.12. Synapse client

**Participants:** Laurent Vanni [contact], Luigi Liquori, Cédric Tedeschi, Vincenzo Ciancaglini.

In order to test our Synapse protocol [21] on real platforms, we have initially developed JSynapse, a Java software prototype, which uses the Java RMI standard for communication between nodes, and whose purpose is to capture the very essence of our Synapse protocol. It is a flexible and ready-to-be-plugged library which can interconnect any type of overlay networks. In particular, JSynapse fully implements a Chord-based inter-overlay network. It was designed to be a lightweight and easy-to-extend software. We also provided some practical classes which help in automating the generation of the inter-overlay network and the testing of specific scenarios. We have experimented with JSynapse on the Grid'5000 platform connecting more than 20 clusters on 9 different sites. Again, Chord was used as the intra-overlay protocol. See, <http://www-sop.inria.fr/teams/lognet/synapse-net2012/>.

## 5.13. Open Synapse client

**Participant:** Bojan Marinkovic [contact].

Opensynapse is an open source implementation of [21]. It is available for free under the GNU GPL. This implementation is based on Open Chord (v. 1.0.5) - an open source implementation of the Chord distributed hash table implementation by Distributed and Mobile Systems Group Lehrstuhl fuer Praktische Informatik Universitaet Bamberg, see <http://www-sop.inria.fr/teams/lognet/synapse-net2012/>.

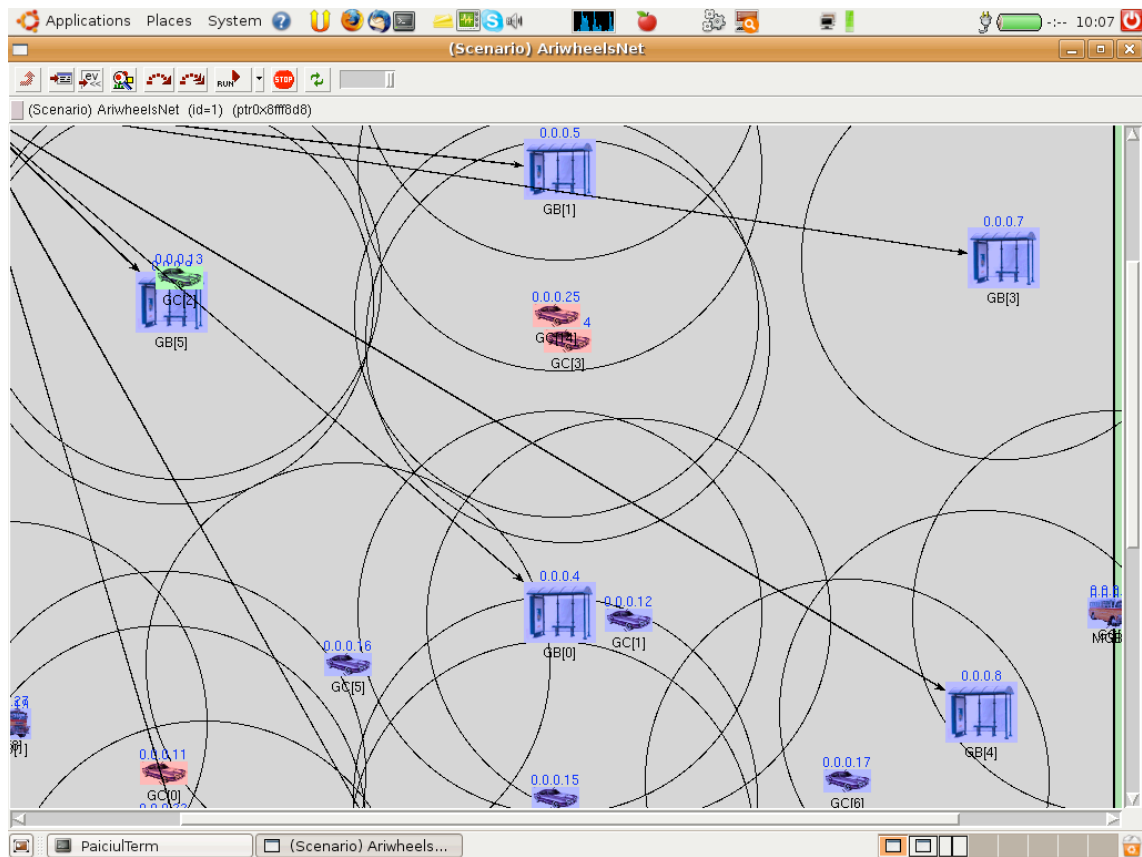

Figure 6. The Ariwheels simulator in Omnet

```

mascotte:~/ARIGATONI/CODE - Konsole
Session Edit View Bookmarks Settings Help

./a.out: /usr/local/lib/libstdc++.so.6: no version information available (required by ./a.out)
./a.out: /usr/local/lib/libstdc++.so.6: no version information available (required by ./a.out)
-t topology_1.net -s 3 -x 0 -r 0 -a 750 -S 128 -p 1234 -N 10000 -ll 1 -g 100 -I 10
100%
ALL CORRECT
AVERAGE # PEERS INVOLVED PER REQUEST (GBUs ONLY | GBUs & GCUs): 19.7828 26.6448
AVERAGE # REQ MESSAGES PER REQUEST (GBUs ONLY | GBUs & GCUs): 20.6098 27.4718
AVERAGE # MESSAGES (ALL TYPES) PER REQUEST (GBUs ONLY | GBUs & GCUs): 68.0267 74.8887
MEAN # REQUESTS FOR DEPTH 0: 10000
MEAN # REQUESTS FOR DEPTH 1: 4131
MEAN # REQUESTS FOR DEPTH 2: 2067.71
MEAN # REQUESTS FOR DEPTH 3: 868.589
MEAN # REQUESTS FOR DEPTH 4: 506.055
MEAN # REQUESTS FOR DEPTH 5: 404.25
MEAN # REQUESTS FOR DEPTH 6: 313.842
MEAN # REQUESTS FOR DEPTH 7: 188.875
MEAN # REQUESTS FOR DEPTH 8: 0
MEAN: 951.096 MIN: 0 MAX: 10000 (ID?) STD DEV: 1625.7 MEDIAN: 43
ACCEPT RATE: 0.513175 REJECT RATE: 0.486825 UNARY ACCEPT RATE: 0.991244 UNARY REJECT RATE: 0.00875567
5

```

Figure 7. The Arigatoni simulator

Opensynapse is implemented on top of an arbitrary number of overlay networks. Inter-networking can be built on top of Synapse in a very efficient way. Synapse is based on co-located nodes playing a role that is reminiscent of neural synapses. The current implementation of Opensynapse in this precise case interconnects many Chord overlay networks. The new client currently can interconnect an arbitrary number of Chord networks. This implementation follows the notation presented in [20], and so, each new Chord network is called a *Floor*.

## 5.14. Husky interpreter

**Participants:** Marthe Bonamy [contact], Luigi Liquori.

Husky is a variable-less language based on lambda calculus and term rewriting systems. Husky is based on the version 1.1 of *Snake*. It was completely rewritten in CAML by Marthe Bonamy, ENSL (new parser, new syntactic constructions, like, *e.g.*, guards, anti-patterns, anti-expressions, exceptions and parametrized pattern matching). In *Husky*, all the keywords of the language are ASCII-symbols. It could be useful for teaching basic algorithms and pattern-matching to children.

## 5.15. myTransport Gui

**Participants:** Laurent Vanni [contact], Vincenzo Ciancaglini, Liquori Liquori.

myTransport is a GUI built on top of the Synapse protocol and network. Its purpose is to be a proof of concept of the future service of info-mobility to be available in the myMed social Network, see Figure 9. The GUI is written in Java and it is fully functional in the Nokia N800 Internet tablet devices. myTransport has been ported to the myMed social network.

## 5.16. myDistributed Catalog for Digitized Cultural Heritage

**Participants:** Vincenzo Ciancaglini [contact], Bojan Marinkovic [MISANU, Serbia], Liquori Liquori.



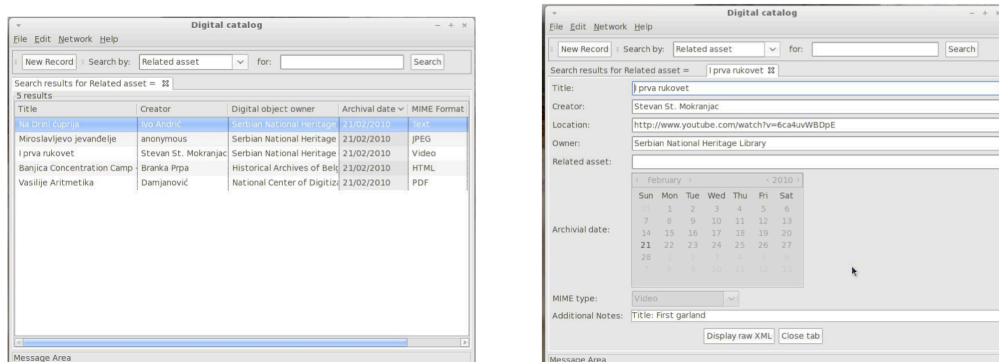

Figure 10. *myDistributed Catalog*

Peer-to-peer networks have emerged recently as a flexible decentralized solution to handle large amount of data without the use of high-end servers. We have implemented a distributed catalog built up on an overlay network called “Synapse”. The Synapse protocol allows interconnection of different overlay networks each of them being an abstraction of a “community” of virtual providers. Data storage and data retrieval from different kind of content providers (i.e. libraries, archives, museums, universities, research centers, etc.) can be stored inside one catalog. We illustrate the concept based on the Synapse protocol: a catalog for digitized cultural heritage of Serbia, see Figure 10.

### 5.17. myStreaming P2P

**Participants:** Vincenzo Ciancaglini [contact], Rossella Fortuna [Politech Bari], Salvatore Spoto [Univ. Turin], Liquori Liquori, Luigi Alfredo Grieco [Politech Bari].

We have implemented, in Python, a fork of Goalbit <http://goalbit.sourceforge.net>, an open source video streaming platform peer-to-peer software streaming platform capable of distributing high-bandwidth live video content to everyone preserving its quality. We have aligned with the classical gossip-based distribution protocol a *DHT* that distribute contents according to a content-based strategy.

## 6. New Results

### 6.1. A Backward-Compatible Protocol for Inter-routing over Heterogeneous Overlay Networks

**Participants:** Giang Ngo Hoang [contact], Luigi Liquori, Hung Nguyen Chan [VIELINA, Vietnam].

Overlay networks are logical networks running on the highest level of the OSI stack: they are applicative networks used by millions of users everyday. In many scenarios, it would be desirable for peers belonging to overlays running different protocols to communicate with each other and exchange certain information. However, due to differences in their respective protocols, this communication is often difficult or even impossible to be achieved efficiently, even if the overlays are sharing common objectives and functionalities. In this paper, we address this problem by presenting a new overlay protocol, called OGP (Overlay Gateway Protocol), allowing different existing networks to route messages between each other in a backward-compatible fashion, by making use of specialized peers joined together into a super-overlay. Experimental results on a large scale Grid5000 infrastructure show that having only a small number of nodes running the OGP protocol is sufficient for achieving efficient routing between heterogeneous overlay networks.



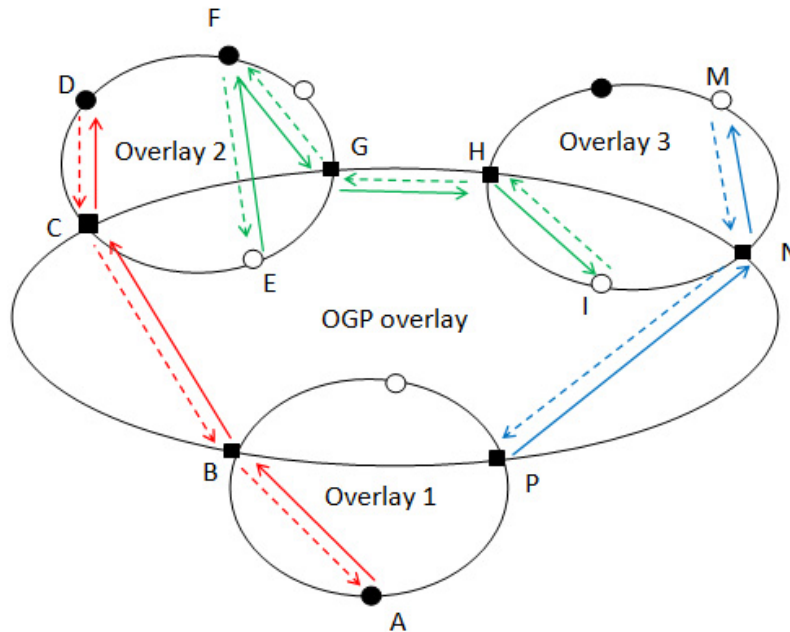

Figure 11. An Overlay Gateway Protocol Topology

The three scenarios in Figure 11 are shown to illustrate the routing of three lookup queries, in which full OGP peers, lightweight OGP peers and blind peers interact in order to reach across overlays represent requests, while dashed lines represent responses. using the OGP super-overlay. The three smaller ovals represent standard overlays, while the largest oval represents the OGP super-overlay, forwarding messages back and forth between standard overlays. The black squares B; C; G; N and P represent full OGP peers, the black circles A; D and F represent lightweight OGP peers, while the white circles E; H, and M represent blind peers. Solid lines requests, while dashed lines represent responses. The paper is the continuation of the work of HotPost 2011 [7] and Hets-Nets 2012 [8]: it has been also accepted to ACM SAC 2013 [36] and a long version has been accepted to the International Conference ICDCN 2014 [32].

## 6.2. Interconnection of large scale unstructured P2P networks: modeling and analysis

**Participants:** Rossano Gaeta [Univ. Turin], Vincenzo Ciancaglini, Riccardo Loti, Luigi Liquori.

Interconnection of multiple P2P networks has recently emerged as a viable solution to increase system reliability and fault-tolerance as well as to increase resource availability. In this paper we consider interconnection of large scale unstructured P2P networks by means of special nodes (called *Synapses*) that are co-located in more than one overlay. Synapses act as *trait d'union* by sending/forwarding a query to all the P2P networks they belong to. Modeling and analysis of the resulting interconnected system is crucial to design efficient and effective search algorithms and to control the cost of interconnection. To this end, we develop a generalized random graph based model that is validated against simulations and it is used to investigate the performance of search algorithms for different interconnection costs and to provide some insight in the characteristics of the interconnection of a large number of P2P networks. To overcome this strong limitation, we develop a generalized random graph based model to represent the topology of one unstructured P2P network, the partition of nodes into Synapses, the probabilistic flooding based search algorithms, and the resource popularity. We

validate our model against simulations and prove that its predictions are reliable and accurate. We use the model to investigate the performance and the cost of different search strategies in terms of the probability of successfully locating at least one copy of the resource and the number of queries as well as the interconnection cost. We also gain interesting insights on the dependency between interconnection cost and statistical properties of the distribution of Synapses. Finally, we show that thanks to our model we can analyze the performance of a system composed of a large number of P2P networks.

To the best of our knowledge, this is the first paper on model-based analysis of interconnection of large scale unstructured P2P networks [11] and the full version has been accepted to the conference [30].

### 6.3. SIEVE: a distributed, accurate, and robust technique to identify malicious nodes in data dissemination on MANET

**Participants:** Rossano Gaeta [Univ. Turin], Riccardo Loti [contact], Marco Grangetto [Univ Turin].

We consider the following problem: nodes in a MANET must disseminate data chunks using rateless codes but some nodes are assumed to be malicious, i.e., before transmitting a coded packet they may modify its payload. Nodes receiving corrupted coded packets are prevented from correctly decoding the original chunk. We propose SIEVE, a fully distributed technique to identify malicious nodes.

SIEVE is based on special messages called *checks* that nodes periodically transmit. A check contains the list of nodes identifiers that provided coded packets of a chunk as well as a flag to signal if the chunk has been corrupted. SIEVE operates on top of an otherwise reliable architecture and it is based on the construction of a *factor graph* obtained from the collected checks on which an incremental belief propagation algorithm is run to compute the probability of a node being malicious. Analysis is carried out by detailed simulations using ns-3. We show that SIEVE is very accurate and discuss how nodes speed impacts on its accuracy. We also show SIEVE robustness under several attack scenarios and deceiving actions. The paper has been accepted to [12] and a journal version in [26].

### 6.4. CCN-TV: a data-centric approach to real-time video services

**Participants:** Luigi Liquori, Vincenzo Ciancaglini [contact], Riccardo Loti, Giuseppe Piro [Politech Bari], Alfredo Grieco [Politech Bari].

Content Centric Networking is a promising data-centric architecture, based on in-network caching, name-driven routing, and receiver-initiated sessions, which can greatly enhance the way Internet resources are currently used, thus making the support for a broader set of users with increasing traffic demands possible. The CCN vision is, currently, attracting the attention of many researchers across the world, because it has all the potential to become ready to the market, to be gradually deployed in the Internet of today, and to facilitate a graceful transition from a host-centric networking rationale to a more effective data-centric working behavior. At the same time, several issues have to be investigated before CCN can be safely deployed at the Internet scale. They include routing, congestion control, caching operations, name-space planning, and application design. With reference to application-related facets, it is worth to notice that the demand for TV services is growing at an exponential rate over the time, thus requiring a very careful analysis of their performance in CCN architectures. To this end, in the present contribution we deploy a CCN-TV system, able to deliver real-time streaming TV services and we evaluate its performance through a simulation campaign based on real topologies. The paper has been accepted to [31] and [28] and a full version has been invited and will appear as book chapter to [33].

### 6.5. Towards a Trust and Reputation Framework for Social Web Platforms and @-economy

**Participants:** Thao Nguyen [contact], Bruno Martin [Unice], Luigi Liquori, Karl Hanks.

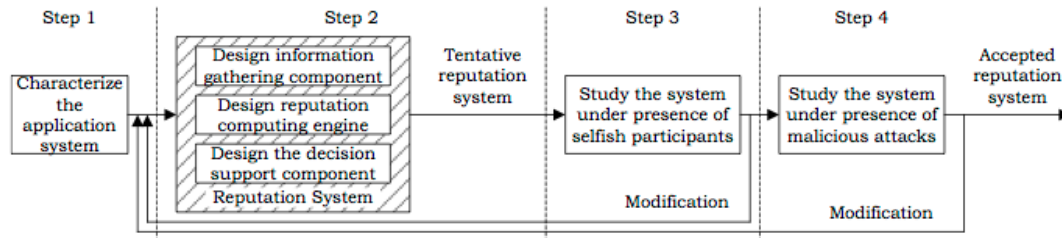

Figure 12. Process of designing a robust trust and reputation system

Trust and reputation systems (TRSs) have recently seen as a vital asset for the safety of online interaction environment. They are present in many practical applications, e.g., e-commerce and social web. A lot of more complicated systems in numerous disciplines also have been studied and proposed in academia. They work as a decision support tool for participants in the system, helping them decide whom to trust and how trustworthy the person is in fulfilling a transaction. They are also an effective mechanism to encourage honesty and cooperation among users, resulting in healthy online markets or communities. The basic idea is to let parties rate each other so that new public knowledge can be created from personal experiences. The greatest challenge in designing a TRS is making it robust against malicious attacks. In this paper, we provide readers an overview on the research topic of TRSs, propose a consistent research agenda in studying and designing a robust TRS, and present an implemented reputation computing engine alongside simulation results, which is our preliminary work to acquire the target of a trust and reputation framework for social web applications.

Information concerning the reputation of individuals has always been spread by word-of-mouth and has been used as an enabler of numerous economic and social activities. Especially now, with the development of technology and, in particular, the Internet, reputation information can be broadcast more easily and faster than ever before. Trust and Reputation Systems (TRSs) have gained the attention of many information and computer scientists since the early 2000s. TRSs have a wide range of applications and are domain specific. The multiple areas where they are applied, include social web platforms, e-commerce, peer-to-peer networks, sensor networks, ad-hoc network routing, and so on. Among these, we are most interested in social web platforms. We observe that trust and reputation is used in many online systems, such as online auction and shopping websites, including eBay, where people buy and sell a broad variety of goods and services, and Amazon, which is a world famous online retailer. Online services with TRSs provide a better safety to their users. A good TRS can also create incentives for good behavior and penalize damaging actions. Markets with the support of TRSs will be healthier, with a variety of prices and quality of service. TRSs are very important for an online community, with respect to the safety of participants, robustness of the network against malicious behavior and for fostering a healthy market.

From a functional point of view, a TRS can be split into three components. The first component gathers feedback on participants' past behavior from the transactions that they were involved in. This component includes storing feedback from users after each transaction they take part in. The second component computes reputation scores for participants through a Reputation Computing Engine (RCE), based on the gathered information. The third component processes the reputation scores, implementing appropriate reward and punishment policies if needed, and representing reputation scores in a way which gives as much support as possible to users' decision-making. A TRS can be centralized or distributed. In centralized TRSs, there is a central authority responsible for collecting ratings and computing reputation scores for users. Most of the TRSs currently on the Internet are centralized, for example the feedback system on eBay and customer reviews

on Amazon. On the other hand, a distributed TRS has no central authority. Each user has to collect ratings and compute reputation scores for other users himself. Almost all proposed TRSs in the literature are distributed.

Some of the main unwanted behaviors of users that might appear in TRSs are: *free riding* (people are usually not willing to give feedback if they are not given an incentive to do so), *untruthful rating* (users give incorrect feedback either because of malicious intent or because of unintended and uncontrolled variables), *colluding* (a group of users coordinate their behavior to inflate each other's reputation scores or bad-mouth other competitors. Colluding motives are only clear in a specific application), *whitewashing* (a user creates a new identity in the system to replace his old one when the reputation of the old one has gone bad), *milking reputation* (at first, a participant behaves correctly to get a high reputation and then turns bad to make a profit from their high reputation score). The milking reputation behavior is more harmful to social network services and e-commerce than to the others.

This research aims to build on these studies and systematize the process of designing a TRS in general as depicted in Fig. 12. First, we characterize the application system into which we want to integrate a TRS, and find and identify new elements of information which substitute for traditional signs of trust and reputation in the physical world. Second, based on the characteristics of the application, we find suitable working mechanisms and processes for each component of the TRS. This step should answer the following questions: "What kind of information do we need to collect and how?", "How should the reputation scores be computed using the collected information?", and "How should they be represented and processed to lead users to a correct decision?". To answer the first question, which corresponds to the information gathering component, we should take advantage of information technology to collect the vast amounts of necessary data. An RCE should meet these criteria: *accuracy* for long-term performance (distinguishing a newcomer with unknown quality from a low-quality participant who has stayed in the system for a long time), *weighting* towards recent behavior, *smoothness* (adding any single rating should not change the score significantly), and *robustness* against attacks. Third, we study the tentative design obtained after the second step in the presence of selfish behaviors. During the third step, we can repeatedly return to Step 2 whenever appropriate until the system reaches a desired performance. The fourth step will refine the TRS and make it more robust against malicious attacks. If a modification is made, we should return to Step 2 and check all the conditions in steps 2 and 3 before accepting the modification. The paper has been accepted to [22] and an improved software and a full paper are in preparation in 2014.

## 6.6. A Scalable Communication Architecture for Advanced Metering Infrastructure

**Participants:** Giang Ngo Hoang [contact], Luigi Liquori, Hung Nguyen Chan [VIELINA, Vietnam].

Advanced Metering Infrastructure (AMI), seen as foundation for overall grid modernization, is an integration of many technologies that provides an intelligent connection between consumers and system operators. One of the biggest challenge that AMI faces is to scalable collect and manage a huge amount of data from a large number of customers. In our paper, we address this challenge by introducing a mixed peer-to-peer (P2P) and client-server communication architecture for AMI in which metering data is aggregated and processed distributedly at multiple levels and in a tree-like manner. Through analysis we show that the architecture is featured with load scalability, resiliency with failure and partly self-organization. The experiments performed in large scale French Grid5000 platform [G5k] shows the communication efficiency in the proposed architecture. A technical report will be submitted to an international conference [37].

## 6.7. An Open Logical Framework

**Participants:** Luigi Liquori [contact], Marina Lenisa [Univ. Udine], Furio Honsell [Univ. Udine], Petar Maksimovic, Ivan Scagnetto [Univ. Udine].

The LFP Framework is an extension of the Harper-Honsell-Plotkin’s Edinburgh Logical Framework LF with external predicates, hence the name Open Logical Framework. This is accomplished by defining lock type constructors, which are a sort of “diamond”-modality constructors, releasing their argument under the condition that a possibly external predicate is satisfied on an appropriate typed judgement. Lock types are defined using the standard pattern of constructive type theory, i.e. via introduction, elimination, and equality rules. Using LFP, one can factor out the complexity of encoding specific features of logical systems which would otherwise be awkwardly encoded in LF, e.g. side-conditions in the application of rules in Modal Logics, and sub-structural rules, as in non-commutative Linear Logic. The idea of LFP is that these conditions need only to be specified, while their verification can be delegated to an external proof engine, in the style of the Poincaré Principle or Deduction Modulo. Indeed such paradigms can be adequately formalized in LFP. We investigate and characterize the meta-theoretical properties of the calculus underpinning LFP: strong normalization, confluence, and subject reduction. This latter property holds under the assumption that the predicates are well-behaved, i.e. closed under weakening, permutation, substitution, and reduction in the arguments. Moreover, we provide a canonical presentation of LFP, based on a suitable extension of the notion of  $\beta\eta$ -long normal form, allowing for smooth formulations of adequacy statements.

LFP is parametric over a potentially unlimited set of (well-behaved) predicates  $\mathcal{P}$ , which are defined on derivable typing judgements of the form  $\Gamma \vdash_{\Sigma} N : \sigma$ , see Fig 13.

$$\frac{\Gamma \vdash_{\Sigma} M : \rho \quad \Gamma \vdash_{\Sigma} N : \sigma}{\Gamma \vdash_{\Sigma} \mathcal{L}_{N,\sigma}^{\mathcal{P}}[M] : \mathcal{L}_{N,\sigma}^{\mathcal{P}}[\rho]} \quad (\text{O-Lock})$$

$$\frac{\Gamma \vdash_{\Sigma} M : \mathcal{L}_{N,\sigma}^{\mathcal{P}}[\rho] \quad \Gamma \vdash_{\Sigma} N : \sigma \quad \mathcal{P}(\Gamma \vdash_{\Sigma} N : \sigma)}{\Gamma \vdash_{\Sigma} \mathcal{U}_{N,\sigma}^{\mathcal{P}}[M] : \rho} \quad (\text{O-Unlock})$$

Figure 13. Some rule of the Open Logical Framework

The syntax of LFP predicates is not specified, with the main idea being that their truth is to be verified via a call to an external validation tool; one can view this externalization as an oracle call. Thus, LFP allows for the invocation of external “modules” which, in principle, can be executed elsewhere, and whose successful verification can be acknowledged in the system via L-reduction. Pragmatically, lock types allow for the factoring out of the complexity of derivations by delegating the {checking, verification, computation} of such predicates to an external proof engine or tool. The proof terms themselves do not contain explicit evidence for external predicates, but just record that a verification {has to be (lock), has been successfully (unlock)} carried out. In this manner, we combine the reliability of formal proof systems based on constructive type theory with the efficiency of other computer tools, in the style of the Poincaré Principle. In this paper, we develop the meta-theory of LFP. Strong normalization and confluence are proven without any additional assumptions on predicates. For subject reduction, we require the predicates to be well-behaved, i.e. closed under weakening, permutation, substitution, and  $\beta\mathcal{L}$ -reduction in the arguments. LFP is decidable, if the external predicates are decidable. We also provide a canonical presentation of LFP, based on a suitable extension of the notion of  $\beta\eta$ -long normal form. This allows for simple proofs of adequacy of the encodings. In particular, we encode in LFP the call-by-value  $\lambda$ -calculus and discuss a possible extension which supports the design-by-contract paradigm. We provide smooth encodings of side conditions in the rules of Modal Logics, both in Hilbert and Natural

Deduction styles. We also encode sub-structural logics, i.e. non-commutative Linear Logic. We also illustrate how LFP can naturally support program correctness systems and Hoare-like logics. In our encodings, we utilize a library of *external predicates*. As far as expressiveness is concerned, LFP is a stepping stone towards a general theory of shallow vs deep encodings, with our encodings being shallow by definition. Clearly, by Church's thesis, all external decidable predicates in LFP can be encoded, possibly with very deep encodings, in standard LF. It would be interesting to state in a precise categorical setting the relationship between such deep internal encodings and the encodings in LFP. LFP can also be viewed as a neat methodology for separating the logical-deductive contents from, on one hand, the verification of structural and syntactical properties, which are often needlessly cumbersome but ultimately computable, or, on the other hand, from more general means of validation. This work has been published in the ACM workshops [13] and [29] and a long version has been invited and appear in the Journal of Logic and Computation [27].

## 7. Bilateral Contracts and Grants with Industry

### 7.1. myMed

**Participants:** Luigi Liquori, The Mymed Team.

Because of the rich founding of the interreg Alcotra myMed contract, also during 2013, we have started few collaborations under the form of "Contrat de prestations". Without going too much into details:

- Ludotic: "IHM for myMed".
- David Da Silva, "autoentrepreneur", "conception et implémentation de 3 social applications myMed".
- Sonya Marcarelli " "autoentrepreneur", "porting of the social applications the Apple Store".
- GIR MARALPIN: "mounting a critical mass for myMed in the euroregion AlpMed".

## 8. Partnerships and Cooperations

### 8.1. European Initiatives

#### 8.1.1. Collaborations in European Programs, except FP7

Program: INTERREG ALCOTRA

Project acronym: myMed

Project title: " a peer-to-peer programmable social network and cloud platform"

Duration: January 2010-march2014

Coordinator: Luigi Liquori

Other partners: University of Turin, Politech of Turin, Univ. of Piemonte Orientale

Founded 1.3Meur on 3 year (2010-2013)

Abstract: see above

### 8.2. International Initiatives

#### 8.2.1. Inria International Partners

- University of Udine, Italy, collaborations, common papers and projects and visits since 1990.
- Politecnico di Torino, Italy, collaborations, common papers and visits since 2000.
- Politecnica de Valencia, Spain, collaborations and projects and teaching and visits since 2004.
- University of Novi Sad, Serbia, collaboration, common projects and papers and visits since 2004.

## 8.3. International Research Visitors

### 8.3.1. Visits of International Scientists

- Demis Ballis, Assistant Professor, Politecnica Valencia, one week,
- Marina Ribaud, Associate professor, Università di Genova, 2 days,
- Giovanni Chiola, Full Professor, Università di Genova, 2 days,
- Seif Aridi, Full Professor, KTH Stockholm, 3 days,
- Nguyen Huu Thanh, Associate Professor, Hanoi University of Science and Technology, one week.

#### 8.3.1.1. Internships

- Nicolas Gauche, IUT Nice, from Apr 2013 until Jun 2013: “conception et implémentation d’un réseau social appelé myCarPooling”;
- Benjamin Lissillour, IUT Nice, from Apr 2013 until Jun 2013: “portage de la base de donnée noSQL Cassandra 0.7 versus la nouvelle release 1.2”;
- Romain Guillot, IUT Nice, from Apr 2013 until Jun 2013: “conception et implémentation d’un système de monitoring pour un cloud de PC distribués, appelé ProtectYourself”.

## 9. Dissemination

### 9.1. Scientific Animation

- reviewing of an ANR blanc proposition;
- reviewing of an Ecos-sud proposition;
- reviewing of TLCA-13,
- program committee of Modularity 2014;

### 9.2. Teaching - Supervision - Juries

#### 9.2.1. Teaching

Master : Luigi Liquori, Peer-to-peer 1, 31.5hTD, M2, Université of Nice Sophia-Antipolis;

#### 9.2.2. Supervision

PhD: Petar Maksimovic, “Development and Verification of Probability Logics and Logical Frameworks”, Faculty of Technical Sciences, University of Novi Sad, Serbia and the University of Nice Sophia Antipolis; Supervisors: Silvia Ghilezan and Luigi Liquori; Defended in October 2013 [24].

PhD: Vincenzo Ciancaglini, “Extending the reach of overlay networks through distributed gateways: design, modeling and applications”, Université de Nice-Sophia Antipolis; Supervisors: Luigi Liquori and Jean-Christophe Pazzaglia (SAP); Defended in July 2013 [23].

PhD: Giang Ngo Hoang, “Inter-heterogeneous overlay co-operation”, Université de Nice-Sophia Antipolis and HUST, Hanoi Institute of Science and Technology, Vietnam; Supervisors: Luigi Liquori and Hung Nguyen Chan (HUST & VIELINA); Defended in December 2013 [25]

PhD in progress: Riccardo Loti, “Modeling and evaluation of protocols for Delay Tolerant Networks exploiting DHT, Content driven routing, and rateless codes”, Université de Nice-Sophia Antipolis and University of Turin Italy; Supervisors: Luigi Liquori and Rossano Gaeta (UNITO); Defense envisaged in the first half of 2014.

PhD in progress: Thao Nguyen, “Trust and reputation management in online marketplaces”, Université de Nice-Sophia Antipolis; Supervisors : Luigi Liquori and Bruno Martin (UNICE); Defense envisaged in the first half of 2014.

#### 9.2.3. Juries

Participating of Raoul Gimenez Ph.D. defense, KTH, Stockholm, December 2013.

### 9.3. Popularization

The LogNet team has conducted two dozen circa of sessions of popularization of the myMed software (typically an “atelier de formation au réseau social myMed”). Public are typically students, administration people of many town or institutions (CG06, Mairies, Hospital, etc.).

## 10. Bibliography

### Major publications by the team in recent years

- [1] D. BENZA, M. COSNARD, L. LIQUORI, M. VESIN. , *Arigatoni: Overlaying Internet via Low Level Network Protocols*, <http://hal.inria.fr/inria-00070219>
- [2] D. BENZA, M. COSNARD, L. LIQUORI, M. VESIN. *Arigatoni: A Simple Programmable Overlay Network*, in "Modern Computing, 2006. JVA '06. IEEE John Vincent Atanasoff 2006 International symposium on Modern Computing", Sofia, Bulgaria, October 2006, <http://hal.inria.fr/hal-00911632>
- [3] D. BORSETTI, C. CASETTI, C.-F. CHIASSERINI, L. LIQUORI. *Content Discovery in Heterogeneous Mobile Networks*, in "Heterogeneous Wireless Access Networks: Architectures and Protocols", E. HOSSAIN (editor), Springer, July 2008, pp. 419-441, <http://hal.inria.fr/hal-00909620>
- [4] R. CHAND, M. COSNARD, L. LIQUORI. *Powerful Resource Discovery for Arigatoni Overlay Network*, in "Future Generation Computer Systems", June 2008, vol. 24, n<sup>o</sup> 1, pp. 31-48, <http://hal.inria.fr/hal-00909630>
- [5] R. CHAND, L. LIQUORI, M. COSNARD. *Improving Resource Discovery in the Arigatoni Overlay Network*, in "ARCS, International Conference on Architecture of Computing Systems", Lecture Notes in Computer Science, Springer-Verlag, 2007, vol. 4415, pp. 98-111
- [6] R. CHAND, L. LIQUORI, M. COSNARD. *Resource Discovery in the Arigatoni Overlay Network*, in "Proc. of IICS'10. International Conference on Innovative Internet Community Services", Neuchatel, Switzerland, June 2010, <http://hal.inria.fr/hal-00910965>
- [7] V. CIANCAGLINI, L. LIQUORI, G. NGO HOANG. *Towards a common architecture to interconnect heterogeneous overlay networks*, in "HotPOST 2011 : The Third International Workshop on Hot Topics in Peer-to-peer computing and Online Social neTworking - HotPost", Tainan, Taiwan, Province De Chine, December 2011, <http://hal.inria.fr/hal-00909477>
- [8] V. CIANCAGLINI, L. LIQUORI, G. NGO HOANG, P. MAKSIMOVIC. *An Extension and Cooperation Mechanism for Heterogeneous Overlay Networks*, in "HetsNets 2012 : Future Heterogeneous Networks", Prague, Tchèque, République, May 2012, <http://hal.inria.fr/hal-00909486>
- [9] M. COSNARD, L. LIQUORI. *Weaving Arigatoni with a graph topology*, in "ADVCOMP 2007, International Conference on Advanced Engineering Computing and Applications in Sciences", Papeete, French Polynesia, November 2007, <http://hal.inria.fr/hal-00911542>
- [10] D. J. DOUGHERTY, L. LIQUORI. *Logic and computation in a lambda calculus with intersection and union types*, in "16th International Conference on Logic for Programming Artificial Intelligence and Reasoning", Dakar, Senegal, April 2010, <http://hal.inria.fr/hal-00909535>
- [11] R. GAETA, V. CIANCAGLINI, R. LOTI, L. LIQUORI. *Modeling and Analysis of Large Scale Interconnected Unstructured P2P Networks*, in "ICDPACD'12. International Conference on Parallel and Distributed Computing", Singapore, Singapour, IEEE, December 2012, <http://hal.inria.fr/hal-00908800>



- [12] R. GAETA, M. GRANGETTO, R. LOTI. *SIEVE: a distributed, accurate, and robust technique to identify malicious nodes in data dissemination on MANET*, in "18th IEEE Int. Conference on parallel and distributed systems", Singapore, Singapour, IEEE Computer Society, December 2012, <http://hal.inria.fr/hal-00911098>
- [13] F. HONSELL, M. LENISA, L. LIQUORI, P. MAKSIMOVIC, I. SCAGNETTO. *LFP - A Logical Framework with External Predicates*, in "7th International Workshop on Logical Frameworks and Meta-languages: Theory and Practice", Copenhagen, Danemark, September 2012, <http://hal.inria.fr/hal-00909455>
- [14] L. LIQUORI, D. BORSETTI, C. CASETTI, C.-F. CHIASSERINI. *An Overlay Architecture for Vehicular Networks*, in "IFIP Networking 2008", Singapore, Singapore, May 2008, <http://hal.inria.fr/hal-00909585>
- [15] L. LIQUORI, M. COSNARD, R. CHAND. *Virtual Organizations in Arigatoni*, in "DCM - Developpement in Computational Methods", Venice, Italy, July 2006, <http://hal.inria.fr/hal-00911535>
- [16] L. LIQUORI, M. COSNARD. *Logical Networks: Towards Foundations for Programmable Overlay Networks and Overlay Computing Systems*, in "Trustworthy Global Computing, Third Symposium, TGC 2007, Sophia-Antipolis, France, November 5-6, 2007, Revised Selected Papers", Sophia-Antipolis, France, June 2008, <http://hal.inria.fr/hal-00909592>
- [17] L. LIQUORI, A. SPIWACK. *Extending FeatherTrait Java with Interfaces*, in "TCS, Theoretical Computer Science", 2008, vol. 398, n<sup>o</sup> 1-3, pp. 243–260, Calculi, types and applications: Essays in honour of M. Coppo, M. Dezani-Ciancaglini and S. Ronchi Della Rocca
- [18] L. LIQUORI, A. SPIWACK. *Extending FeatherTrait Java with Interfaces*, in "Theoretical Computer Science", 2008 [DOI : 10.1016/J.TCS.2008.01.051], <http://hal.inria.fr/inria-00432540>
- [19] L. LIQUORI, A. SPIWACK. *FeatherTrait: A Modest Extension of Featherweight Java*, in "ACM Transactions on Programming Languages and Systems", 2008, 32 p. [DOI : 10.1145/1330017.1330022], <http://hal.inria.fr/inria-00432538>
- [20] L. LIQUORI, C. TEDESCHI, F. BONGIOVANNI. *Babelchord: a Social Tower of DHT-Based Overlay Networks*, in "IEEE Symposium on Computers and Communications (ISCC'09)", Sousse, Tunisie, July 2009, <http://hal.inria.fr/hal-00909550>
- [21] L. LIQUORI, C. TEDESCHI, L. VANNI, F. BONGIOVANNI, V. CIANCAGLINI, B. MARINKOVIC. *Synapse: A Scalable Protocol for Interconnecting Heterogeneous Overlay Networks\**, in "9th International IFIP TC 6 Networking Conference", Chennai, Inde, May 2010, <http://hal.inria.fr/hal-00909544>
- [22] T. NGUYEN, L. LIQUORI, B. MARTIN, K. HANKS. *Towards a Trust and Reputation Framework for Social Web Platforms*, in "On the Move to Meaningful Internet Systems: OTM 2012", Rome, Italie, Springer, September 2012, pp. 13-22, <http://hal.inria.fr/hal-00908805>

## Publications of the year

### Doctoral Dissertations and Habilitation Theses

- [23] V. CIANCAGLINI. , *Du routage par clé au routage par contenu : interconnexion des systèmes et applications de diffusion vidéo*, Université Nice Sophia Antipolis, July 2013, <http://hal.inria.fr/tel-00875653>

- [24] P. MAKSIMOVIĆ. , *Développement et vérification des logiques probabilistes et des cadres logiques*, Université Nice Sophia Antipolis and Univerzitet u Novom Sadu, October 2013, <http://hal.inria.fr/tel-00907854>
- [25] G. NGO HOANG. , *De l'Interconnexion des Réseaux de Recouvrement à la Cooperation des Systèmes Pair-à-Pair*, Université Nice Sophia Antipolis and Hanoi University of Science and Technology, December 2013, <http://hal.inria.fr/tel-00921367>

### Articles in International Peer-Reviewed Journals

- [26] R. GAETA, M. GRANGETTO, R. LOTI. *Exploiting rateless codes and belief propagation to infer identity of polluters in MANET*, in "IEEE Transactions on Mobile Computing", January 2014 [DOI : 10.1109/TMC.2013.137], <http://hal.inria.fr/hal-00911724>
- [27] F. HONSELL, M. LENISA, L. LIQUORI, P. MAKSIMOVIC, I. SCAGNETTO. *An Open Logical Framework*, in "Journal of Logic and Computation", October 2013 [DOI : 10.1093/LOGCOM/EXT028], <http://hal.inria.fr/hal-00906391>
- [28] G. PIRO, V. CIANCAGLINI. *Enabling real-time TV services in CCN networks*, in "IEEE COMSOC MMTC E-Letter", July 2013, pp. 17-20, <http://hal.inria.fr/hal-00921318>

### Invited Conferences

- [29] F. HONSELL, I. SCAGNETTO, L. LIQUORI, P. MAKSIMOVIC. *Extended Abstract: 25 Years of Formal Proof Cultures*, in "Logic: Between Semantics and Proof Theory A Workshop in Honor of Prof. Arnon Avron's 60th Birthday", Tel Aviv, Israel, November 2013, invited in a special issue of JLP, <http://hal.inria.fr/hal-00906807>

### International Conferences with Proceedings

- [30] V. CIANCAGLINI, R. GAETA, R. LOTI, L. LIQUORI. *Interconnection of large scale unstructured P2P networks: modeling and analysis*, in "ASMTA - 20th International Conference on Analytical and Stochastic Modelling and Applications - 2013", Gent, Belgium, A. DUDIN, K. D. TURCK (editors), Lecture Notes in Computer Science, Springer, July 2013, vol. 7984, pp. 183-197 [DOI : 10.1007/978-3-642-39408-9\_14], <http://hal.inria.fr/hal-00906823>
- [31] V. CIANCAGLINI, G. PIRO, R. LOTI, L. LIQUORI, L. A. GRIECO. *CCN-TV: a data-centric approach to real-time video services*, in "International Conference on Advanced Information Networking and Applications", Barcelona, Spain, March 2013, <http://hal.inria.fr/hal-00906830>
- [32] G. NGO HOANG, L. LIQUORI, H. NGUYEN CHAN. *Backward-Compatible Cooperation of Heterogeneous P2P Systems*, in "5th International Conference on Distributed Computing and Networking", Coimbatore, India, January 2014, <http://hal.inria.fr/hal-00906798>

### Scientific Books (or Scientific Book chapters)

- [33] G. PIRO, V. CIANCAGLINI, R. LOTI, L. A. GRIECO, L. LIQUORI. *Providing crowd-sourced and real-time media services through a NDN-based platform*, in "Modelling and processing for next generation big data technologies and applications", F. XHAFI (editor), Springer, September 2013, <http://hal.inria.fr/hal-00906475>

### Books or Proceedings Editing

- [34] L. LIQUORI, MYMED CONSORTIUM INTERREG ALCOTRA. , L. LIQUORI (editor), *Rapport final d'execution du projet myMed / Rapporto finale di esecuzione del progetto myMed 2010-2013*. Interreg Alcotra, Office Interreg Alcotra, September 2013, 60 p. , <http://hal.inria.fr/hal-00909658>

### **Research Reports**

- [35] H. G. NGO, L. LIQUORI, C. HUNG NGUYEN. , *A Scalable Communication Architecture for AMI in SmartGrid*, Inria, December 2013, n<sup>o</sup> RR-8410, <http://hal.inria.fr/hal-00913352>

### **Other Publications**

- [36] G. NGO HOANG, L. LIQUORI, V. CIANCAGLINI, P. MAKSIMOVIC, H. NGUYEN CHAN. , *A Backward-Compatible Protocol for Inter-routing over Heterogeneous Overlay Networks*, March 2013, Poster and short (2 pages paper), <http://hal.inria.fr/hal-00906835>
- [37] G. NGO HOANG, L. LIQUORI, H. NGUYEN CHAN. , *A Scalable Communication Architecture for Advanced Metering Infrastructure*, November 2013, <http://hal.inria.fr/hal-00909699>