



Activity Report 2017

Project-Team APICS

Analysis and Problems of Inverse type in
Control and Signal processing

RESEARCH CENTER
Sophia Antipolis - Méditerranée

THEME
**Optimization and control of dynamic
systems**

Table of contents

1. Personnel	1
2. Overall Objectives	2
3. Research Program	2
3.1. Introduction	2
3.2. Range of inverse problems	4
3.2.1. Elliptic partial differential equations (PDE)	4
3.2.2. Systems, transfer and scattering	6
3.3. Approximation	7
3.3.1. Best analytic approximation	7
3.3.2. Best meromorphic and rational approximation	9
3.3.2.1. Scalar meromorphic and rational approximation	9
3.3.2.2. Matrix-valued rational approximation	10
3.3.3. Behavior of poles of meromorphic approximants	11
3.4. Software tools of the team	11
3.4.1. DEDALE-HF	11
3.4.2. FindSources3D	12
3.4.3. PRESTO-HF	12
3.4.4. RARL2	13
3.4.5. Sollya	14
4. Application Domains	14
4.1. Introduction	14
4.2. Inverse magnetization problems	14
4.3. Inverse source problems in EEG	15
4.4. Identification and design of microwave devices	16
5. New Results	19
5.1. Inverse problems for Poisson-Laplace equations	19
5.1.1. Inverse magnetization issues from planar data	19
5.1.2. Inverse magnetization issues from sparse cylindrical data	21
5.1.3. Inverse problems in medical imaging	23
5.2. Matching problems and their applications	24
5.2.1. Approach based on interpolation	25
5.2.2. Uniform matching and global optimality considerations	26
5.3. Stability assessment of microwave amplifiers and design of oscillators	26
5.4. The Hardy-Hodge decomposition	27
6. Bilateral Contracts and Grants with Industry	28
6.1.1. Contract CNES-Inria-XLIM	28
6.1.2. Contract BESA GmbH-Inria	28
6.1.3. Contract Inria-SKAVENJI	28
7. Partnerships and Cooperations	28
7.1. Regional Initiatives	28
7.2. National Initiatives	29
7.2.1. ANR Cocoram	29
7.2.2. ANR MagLune	29
7.3. European Initiatives	29
7.4. International Initiatives	29
7.4.1. Inria Associate Teams Not Involved in an Inria International Labs	29
7.4.2. Inria International Partners	29
7.5. International Research Visitors	30
7.5.1. Visits of International Scientists	30

7.5.2. Visits to International Teams	30
7.6. List of international and industrial partners	30
8. Dissemination	31
8.1. Promoting Scientific Activities	31
8.1.1. Scientific Events Organisation	31
8.1.1.1. General Chair, Scientific Chair	31
8.1.1.2. Member of the Organizing Committees	31
8.1.2. Scientific Events Selection	31
8.1.3. Journal	31
8.1.3.1. Member of the Editorial Boards	31
8.1.3.2. Reviewer - Reviewing Activities	32
8.1.4. Invited Talks	32
8.1.5. Scientific Expertise	32
8.1.6. Research Administration	32
8.2. Teaching - Supervision - Juries	32
8.2.1. Teaching	32
8.2.2. Supervision	33
8.2.3. Juries	33
8.3. Popularization	33
9. Bibliography	34

Project-Team APICS

Creation of the Project-Team: 2005 January 01, end of the Project-Team: 2017 December 31

Keywords:

Computer Science and Digital Science:

- A6.1.1. - Continuous Modeling (PDE, ODE)
- A6.2. - Scientific Computing, Numerical Analysis & Optimization
 - A6.2.1. - Numerical analysis of PDE and ODE
 - A6.2.5. - Numerical Linear Algebra
 - A6.2.6. - Optimization
- A6.3.1. - Inverse problems
- A6.3.3. - Data processing
- A6.3.4. - Model reduction
- A6.4. - Automatic control
 - A6.4.4. - Stability and Stabilization
- A8.2. - Optimization
- A8.3. - Geometry, Topology
- A8.4. - Computer Algebra

Other Research Topics and Application Domains:

- B2.6. - Biological and medical imaging
 - B2.6.1. - Brain imaging
- B3. - Environment and planet
 - B3.3. - Geosciences
 - B3.3.1. - Earth and subsoil
- B5.2. - Design and manufacturing
 - B5.2.4. - Aerospace
- B5.4. - Microelectronics
- B6.2.2. - Radio technology
- B6.2.3. - Satellite technology

1. Personnel

Research Scientists

- Laurent Baratchart [Inria, Senior Researcher, Team leader, HDR]
- Sylvain Chevillard [Inria, Researcher]
- Juliette Leblond [Inria, Senior Researcher, HDR]
- Martine Olivi [Inria, Researcher, HDR]
- Fabien Seyfert [Inria, Researcher]

Post-Doctoral Fellow

- Adam Cooman [Inria, Post-doctoral fellow]

PhD Students

- Gibin Bose [Inria and LEAT, PhD Student, CORDI-C granted by Labex UCN@Sophia]
- Sébastien Fueyo [Inria, PhD Student, CORDI-S]

David Martinez Martinez [Inria and Université de Limoges, PhD Student, granted by CNES and DGA]
Konstantinos Mavreas [Université Côte d'Azur UCA, PhD Student, granted by MESR]
Christos Papageorgakis [Inria and Company BESA GmbH, PhD Student, CORDI-C granted by BESA GmbH and Region PACA; part time with the team Athena]

Intern

Gautier Dervaux [IMT Atlantique Brest internship, two months]

Administrative Assistant

Marie-Line Meirinho [Inria Assistant]

External Collaborator

Jean-Paul Marmorat [École des Mines ParisTech, Centre Math. App. (CMA)]

2. Overall Objectives

2.1. Research Themes

The team develops constructive, function-theoretic approaches to inverse problems arising in modeling and design, in particular for electro-magnetic systems as well as in the analysis of certain classes of signals.

Data typically consist of measurements or desired behaviors. The general thread is to approximate them by families of solutions to the equations governing the underlying system. This leads us to consider various interpolation and approximation problems in classes of rational and meromorphic functions, harmonic gradients, or solutions to more general elliptic partial differential equations (PDE), in connection with inverse potential problems. A recurring difficulty is to control the singularities of the approximants.

The mathematical tools pertain to complex and harmonic analysis, approximation theory, potential theory, system theory, differential topology, optimization and computer algebra. Targeted applications include:

- identification and synthesis of analog microwave devices (filters, amplifiers),
- non-destructive control from field measurements in medical engineering (source recovery in magneto/electro-encephalography), and paleomagnetism (determining the magnetization of rock samples).

In each case, the endeavor is to develop algorithms resulting in dedicated software.

3. Research Program

3.1. Introduction

Within the extensive field of inverse problems, much of the research by Apics deals with reconstructing solutions of classical elliptic PDEs from their boundary behavior. Perhaps the simplest example lies with harmonic identification of a stable linear dynamical system: the transfer-function f can be evaluated at a point $i\omega$ of the imaginary axis from the response to a periodic input at frequency ω . Since f is holomorphic in the right half-plane, it satisfies there the Cauchy-Riemann equation $\bar{\partial}f = 0$, and recovering f amounts to solve a Dirichlet problem which can be done in principle using, *e.g.* the Cauchy formula.

Practice is not nearly as simple, for f is only measured pointwise in the pass-band of the system which makes the problem ill-posed [71]. Moreover, the transfer function is usually sought in specific form, displaying the necessary physical parameters for control and design. For instance if f is rational of degree n , then $\bar{\partial}f = \sum_1^n a_j \delta_{z_j}$ where the z_j are its poles and δ_{z_j} is a Dirac unit mass at z_j . Thus, to find the domain of holomorphy (*i.e.* to locate the z_j) amounts to solve a (degenerate) free-boundary inverse problem, this time on the left half-plane. To address such questions, the team has developed a two-step approach as follows.

Step 1: To determine a complete model, that is, one which is defined at every frequency, in a sufficiently versatile function class (*e.g.* Hardy spaces). This ill-posed issue requires regularization, for instance constraints on the behavior at non-measured frequencies.

Step 2: To compute a reduced order model. This typically consists of rational approximation of the complete model obtained in step 1, or phase-shift thereof to account for delays. We emphasize that deriving a complete model in step 1 is crucial to achieve stability of the reduced model in step 2.

Step 1 relates to extremal problems and analytic operator theory, see Section 3.3.1. Step 2 involves optimization, and some Schur analysis to parametrize transfer matrices of given Mc-Millan degree when dealing with systems having several inputs and outputs, see Section 3.3.2.2. It also makes contact with the topology of rational functions, in particular to count critical points and to derive bounds, see Section 3.3.2. Step 2 raises further issues in approximation theory regarding the rate of convergence and the extent to which singularities of the approximant (*i.e.* its poles) tend to singularities of the approximated function; this is where logarithmic potential theory becomes instrumental, see Section 3.3.3.

Applying a realization procedure to the result of step 2 yields an identification procedure from incomplete frequency data which was first demonstrated in [77] to tune resonant microwave filters. Harmonic identification of nonlinear systems around a stable equilibrium can also be envisaged by combining the previous steps with exact linearization techniques from [35].

A similar path can be taken to approach design problems in the frequency domain, replacing the measured behavior by some desired behavior. However, describing achievable responses in terms of the design parameters is often cumbersome, and most constructive techniques rely on specific criteria adapted to the physics of the problem. This is especially true of filters, the design of which traditionally appeals to polynomial extremal problems [73], [58]. Apics contributed to this area the use of Zolotarev-like problems for multi-band synthesis, although we presently favor interpolation techniques in which parameters arise in a more transparent manner, as well as convex relaxation of hyperbolic approximation problems, see Sections 3.2.2 and 5.2.2.

The previous example of harmonic identification quickly suggests a generalization of itself. Indeed, on identifying \mathbb{C} with \mathbb{R}^2 , holomorphic functions become conjugate-gradients of harmonic functions, so that harmonic identification is, after all, a special case of a classical issue: to recover a harmonic function on a domain from partial knowledge of the Dirichlet-Neumann data; when the portion of boundary where data are not available is itself unknown, we meet a free boundary problem. This framework for 2-D non-destructive control was first advocated in [63] and subsequently received considerable attention. It makes clear how to state similar problems in higher dimensions and for more general operators than the Laplacian, provided solutions are essentially determined by the trace of their gradient on part of the boundary which is the case for elliptic equations ¹ [32], [81]. Such questions are particular instances of the so-called inverse potential problem, where a measure μ has to be recovered from the knowledge of the gradient of its potential (*i.e.*, the field) on part of a hypersurface (a curve in 2-D) encompassing the support of μ . For Laplace's operator, potentials are logarithmic in 2-D and Newtonian in higher dimensions. For elliptic operators with non constant coefficients, the potential depends on the form of fundamental solutions and is less manageable because it is no longer of convolution type. Nevertheless it is a useful concept bringing perspective on how problems could be raised and solved, using tools from harmonic analysis.

¹There is a subtle difference here between dimension 2 and higher. Indeed, a function holomorphic on a plane domain is defined by its non-tangential limit on a boundary subset of positive linear measure, but there are non-constant harmonic functions in the 3-D ball, C^1 up to the boundary sphere, yet having vanishing gradient on a subset of positive measure of the sphere. Such a "bad" subset, however, cannot have interior points on the sphere.

Inverse potential problems are severely indeterminate because infinitely many measures within an open set produce the same field outside this set; this phenomenon is called *balayage* [70]. In the two steps approach previously described, we implicitly removed this indeterminacy by requiring in step 1 that the measure be supported on the boundary (because we seek a function holomorphic throughout the right half-space), and by requiring in step 2 that the measure be discrete in the left half-plane (in fact: a sum of point masses $\sum_1^n a_j \delta_{z_j}$). The discreteness assumption also prevails in 3-D inverse source problems, see Section 4.3. Conditions that ensure uniqueness of the solution to the inverse potential problem are part of the so-called regularizing assumptions which are needed in each case to derive efficient algorithms.

To recap, the gist of our approach is to approximate boundary data by (boundary traces of) fields arising from potentials of measures with specific support. This differs from standard approaches to inverse problems, where descent algorithms are applied to integration schemes of the direct problem; in such methods, it is the equation which gets approximated (in fact: discretized).

Along these lines, Apics advocates the use of steps 1 and 2 above, along with some singularity analysis, to approach issues of nondestructive control in 2-D and 3-D [2], [42], [46]. The team is currently engaged in the generalization to inverse source problems for the Laplace equation in 3-D, to be described further in Section 3.2.1. There, holomorphic functions are replaced by harmonic gradients; applications are to inverse source problems in neurosciences (in particular in EEG/MEG) and inverse magnetization problems in geosciences, see Section 4.3.

The approximation-theoretic tools developed by Apics to handle issues mentioned so far are outlined in Section 3.3. In Section 3.2 to come, we describe in more detail which problems are considered and which applications are targeted.

Apics is reaching the end of its 12 years life cycle. A reorganization of the team and of some of its research themes is under way through the project proposal FACTAS.

3.2. Range of inverse problems

3.2.1. Elliptic partial differential equations (PDE)

Participants: Laurent Baratchart, Sylvain Chevillard, Juliette Leblond, Konstantinos Mavreas, Christos Papageorgakis.

By standard properties of conjugate differentials, reconstructing Dirichlet-Neumann boundary conditions for a function harmonic in a plane domain, when these conditions are already known on a subset E of the boundary, is equivalent to recover a holomorphic function in the domain from its boundary values on E . This is the problem raised on the half-plane in step 1 of Section 3.1. It makes good sense in holomorphic Hardy spaces where functions are entirely determined by their values on boundary subsets of positive linear measure, which is the framework for Problem (P) that we set up in Section 3.3.1. Such issues naturally arise in nondestructive testing of 2-D (or 3-D cylindrical) materials from partial electrical measurements on the boundary. For instance, the ratio between the tangential and the normal currents (the so-called Robin coefficient) tells one about corrosion of the material. Thus, solving Problem (P) where ψ is chosen to be the response of some uncorroded piece with identical shape yields non destructive testing of a potentially corroded piece of material, part of which is inaccessible to measurements. This was an initial application of holomorphic extremal problems to non-destructive control [56], [59].

Another application by the team deals with non-constant conductivity over a doubly connected domain, the set E being now the outer boundary. Measuring Dirichlet-Neumann data on E , one wants to recover level lines of the solution to a conductivity equation, which is a so-called free boundary inverse problem. For this, given a closed curve inside the domain, we first quantify how constant the solution on this curve. To this effect, we state and solve an analog of Problem (P), where the constraint bears on the real part of the function on the curve (it should be close to a constant there), in a Hardy space of a conjugate Beltrami equation, of which the considered conductivity equation is the compatibility condition (just like the Laplace equation is the compatibility condition of the Cauchy-Riemann system). Subsequently, a descent algorithm on the curve

leads one to improve the initial guess. For example, when the domain is regarded as separating the edge of a tokamak's vessel from the plasma (rotational symmetry makes this a 2-D situation), this method can be used to estimate the shape of a plasma subject to magnetic confinement. This was actually carried out in collaboration with CEA (French nuclear agency) and the University of Nice (JAD Lab.), to data from *Tore Supra* [62]. The procedure is fast because no numerical integration of the underlying PDE is needed, as an explicit basis of solutions to the conjugate Beltrami equation in terms of Bessel functions was found in this case. Generalizing this approach in a more systematic manner to free boundary problems of Bernoulli type, using descent algorithms based on shape-gradient for such approximation-theoretic criteria, is an interesting prospect to the team.

The piece of work we just mentioned requires defining and studying Hardy spaces of the conjugate-Beltrami equation, which is an interesting topic by itself. For Sobolev-smooth coefficients of exponent greater than 2, they were investigated in [5], [36]. The case of the critical exponent 2 is treated in [31], which apparently provides the first example of well-posedness for the Dirichlet problem in the non-strictly elliptic case: the conductivity may be unbounded or zero on sets of zero capacity and, accordingly, solutions need not be locally bounded. More importantly perhaps, the exponent 2 is also the key to a corresponding theory on very general (still rectifiable) domains in the plane, as coefficients of pseudo-holomorphic functions obtained by conformal transformation onto a disk are merely of L^2 -class in general, even if the initial problem deals with coefficients of L^r -class for some $r > 2$.

Generalized Hardy classes as above are used in [32] where we address the uniqueness issue in the classical Robin inverse problem on a Lipschitz domain of $\Omega \subset \mathbb{R}^n$, $n \geq 2$, with uniformly bounded Robin coefficient, L^2 Neumann data and conductivity of Sobolev class $W^{1,r}(\Omega)$, $r > n$. We show that uniqueness of the Robin coefficient on a subset of the boundary, given Cauchy data on the complementary part, does hold in dimension $n = 2$, thanks to a unique continuation result, but needs not hold in higher dimension. In higher dimension, this raises an open issue on harmonic gradients, namely whether the positivity of the Robin coefficient is compatible with identical vanishing of the boundary gradient on a subset of positive measure.

The 3-D version of step 1 in Section 3.1 is another subject investigated by Apics: to recover a harmonic function (up to an additive constant) in a ball or a half-space from partial knowledge of its gradient. This prototypical inverse problem (*i.e.* inverse to the Cauchy problem for the Laplace equation) often recurs in electromagnetism. At present, Apics is involved with solving instances of this inverse problem arising in two fields, namely medical imaging *e.g.* for electroencephalography (EEG) or magneto-encephalography (MEG), and paleomagnetism (recovery of rocks magnetization) [2], [38], see Section 5.1. In this connection, we collaborate with two groups of partners: Athena Inria project-team, CHU La Timone, and BESA company on the one hand, Geosciences Lab. at MIT and Cerege CNRS Lab. on the other hand. The question is considerably more difficult than its 2-D counterpart, due mainly to the lack of multiplicative structure for harmonic gradients. Still, substantial progress has been made over the last years using methods of harmonic analysis and operator theory.

The team is further concerned with 3-D generalizations and applications to non-destructive control of step 2 in Section 3.1. A typical problem is here to localize inhomogeneities or defaults such as cracks, sources or occlusions in a planar or 3-dimensional object, knowing thermal, electrical, or magnetic measurements on the boundary. These defaults can be expressed as a lack of harmonicity of the solution to the associated Dirichlet-Neumann problem, thereby posing an inverse potential problem in order to recover them. In 2-D, finding an optimal discretization of the potential in Sobolev norm amounts to solve a best rational approximation problem, and the question arises as to how the location of the singularities of the approximant (*i.e.* its poles) reflects the location of the singularities of the potential (*i.e.* the defaults we seek). This is a fairly deep issue in approximation theory, to which Apics contributed convergence results for certain classes of fields expressed as Cauchy integrals over extremal contours for the logarithmic potential [6], [39], [53]. Initial schemes to locate cracks or sources *via* rational approximation on planar domains were obtained this way [42], [46], [56]. It is remarkable that finite inverse source problems in 3-D balls, or more general algebraic surfaces, can be approached using these 2-D techniques upon slicing the domain into planar sections [7], [43]. More precisely, each section cuts out a planar domain, the boundary of which carries data which can be proved to match

an algebraic function. The singularities of this algebraic function are not located at the 3-D sources, but are related to them: the section contains a source if and only if some function of the singularities in that section meets a relative extremum. Using bisection it is thus possible to determine an extremal place along all sections parallel to a given plane direction, up to some threshold which has to be chosen small enough that one does not miss a source. This way, we reduce the original source problem in 3-D to a sequence of inverse poles and branchpoints problems in 2-D. This bottom line generates a steady research activity within Apics, and again applications are sought to medical imaging and geosciences, see Sections 4.3, 4.2 and 5.1.

Conjectures may be raised on the behavior of optimal potential discretization in 3-D, but answering them is an ambitious program still in its infancy.

3.2.2. Systems, transfer and scattering

Participants: Laurent Baratchart, Sylvain Chevillard, Adam Cooman, Martine Olivi, Fabien Seyfert.

Through contacts with CNES (French space agency), members of the team became involved in identification and tuning of microwave electromagnetic filters used in space telecommunications, see Section 4.4. The initial problem was to recover, from band-limited frequency measurements, physical parameters of the device under examination. The latter consists of interconnected dual-mode resonant cavities with negligible loss, hence its scattering matrix is modeled by a 2×2 unitary-valued matrix function on the frequency line, say the imaginary axis to fix ideas. In the bandwidth around the resonant frequency, a modal approximation of the Helmholtz equation in the cavities shows that this matrix is approximately rational, of Mc-Millan degree twice the number of cavities.

This is where system theory comes into play, through the so-called *realization* process mapping a rational transfer function in the frequency domain to a state-space representation of the underlying system of linear differential equations in the time domain. Specifically, realizing the scattering matrix allows one to construct a virtual electrical network, equivalent to the filter, the parameters of which mediate in between the frequency response and the geometric characteristics of the cavities (*i.e.* the tuning parameters).

Hardy spaces provide a framework to transform this ill-posed issue into a series of regularized analytic and meromorphic approximation problems. More precisely, the procedure sketched in Section 3.1 goes as follows:

1. infer from the pointwise boundary data in the bandwidth a stable transfer function (*i.e.* one which is holomorphic in the right half-plane), that may be infinite dimensional (numerically: of high degree). This is done by solving a problem analogous to (P) in Section 3.3.1, while taking into account prior knowledge on the decay of the response outside the bandwidth, see [9] for details.
2. A stable rational approximation of appropriate degree to the model obtained in the previous step is performed. For this, a descent method on the compact manifold of inner matrices of given size and degree is used, based on an original parametrization of stable transfer functions developed within the team [27], [9].
3. Realizations of this rational approximant are computed. To be useful, they must satisfy certain constraints imposed by the geometry of the device. These constraints typically come from the coupling topology of the equivalent electrical network used to model the filter. This network is composed of resonators, coupled according to some specific graph. This realization step can be recast, under appropriate compatibility conditions [57], as solving a zero-dimensional multivariate polynomial system. To tackle this problem in practice, we use Gröbner basis techniques and continuation methods which team up in the Dedale-HF software (see Section 3.4.1).

Let us mention that extensions of classical coupling matrix theory to frequency-dependent (reactive) couplings have been carried-out in recent years [1] for wide-band design applications.

Apics also investigates issues pertaining to design rather than identification. Given the topology of the filter, a basic problem in this connection is to find the optimal response subject to specifications that bear on rejection, transmission and group delay of the scattering parameters. Generalizing the classical approach based on Chebyshev polynomials for single band filters, we recast the problem of multi-band response synthesis as

a generalization of the classical Zolotarev min-max problem for rational functions [26] [8]. Thanks to quasi-convexity, the latter can be solved efficiently using iterative methods relying on linear programming. These were implemented in the software easy-FF (see [easy-FF](#)). Currently, the team is engaged in the synthesis of more complex microwave devices like multiplexers and routers, which connect several filters through wave guides. Schur analysis plays an important role here, because scattering matrices of passive systems are of Schur type (*i.e.* contractive in the stability region). The theory originates with the work of I. Schur [76], who devised a recursive test to check for contractivity of a holomorphic function in the disk. The so-called Schur parameters of a function may be viewed as Taylor coefficients for the hyperbolic metric of the disk, and the fact that Schur functions are contractions for that metric lies at the root of Schur's test. Generalizations thereof turn out to be efficient to parametrize solutions to contractive interpolation problems [28]. Dwelling on this, Apics contributed differential parametrizations (atlases of charts) of lossless matrix functions [27], [72], [67] which are fundamental to our rational approximation software RARL2 (see Section 3.4.4). Schur analysis is also instrumental to approach de-embedding issues, and provides one with considerable insight into the so-called matching problem. The latter consists in maximizing the power a multiport can pass to a given load, and for reasons of efficiency it is all-pervasive in microwave and electric network design, *e.g.* of antennas, multiplexers, wifi cards and more. It can be viewed as a rational approximation problem in the hyperbolic metric, and the team presently deals with this hot topic using contractive interpolation with constraints on boundary peak points, within the framework of the (defense funded) ANR Cocoram, see Sections 5.2 and 7.2.1.

In recent years, our attention was driven by CNES and UPV (Bilbao) to questions about stability of high-frequency amplifiers. Contrary to previously discussed devices, these are *active* components. The response of an amplifier can be linearized around a set of primary current and voltages, and then admittances of the corresponding electrical network can be computed at various frequencies, using the so-called harmonic balance method. The initial goal is to check for stability of the linearized model, so as to ascertain existence of a well-defined working state. The network is composed of lumped electrical elements namely inductors, capacitors, negative *and* positive reactors, transmission lines, and controlled current sources. Our research so far has focused on describing the algebraic structure of admittance functions, so as to set up a function-theoretic framework where the two-steps approach outlined in Section 3.1 can be put to work. The main discovery is that the unstable part of each partial transfer function is rational and can be computed by analytic projection, see Section 5.3. We now start investigating the linearized harmonic transfer-function around a periodic cycle, to check for stability under non necessarily small inputs. This generalization generates both doctoral and postdoctoral work by new students in the team.

3.3. Approximation

Participants: Laurent Baratchart, Sylvain Chevillard, Juliette Leblond, Martine Olivi, Fabien Seyfert.

3.3.1. Best analytic approximation

In dimension 2, the prototypical problem to be solved in step 1 of Section 3.1 may be described as: given a domain $D \subset \mathbb{R}^2$, to recover a holomorphic function from its values on a subset K of the boundary of D . For the discussion it is convenient to normalize D , which can be done by conformal mapping. So, in the simply connected case, we fix D to be the unit disk with boundary unit circle T . We denote by H^p the Hardy space of exponent p , which is the closure of polynomials in $L^p(T)$ -norm if $1 \leq p < \infty$ and the space of bounded holomorphic functions in D if $p = \infty$. Functions in H^p have well-defined boundary values in $L^p(T)$, which makes it possible to speak of (traces of) analytic functions on the boundary.

To find an analytic function g in D matching some measured values f approximately on a sub-arc K of T , we formulate a constrained best approximation problem as follows.

(P) Let $1 \leq p \leq \infty$, K a sub-arc of T , $f \in L^p(K)$, $\psi \in L^p(T \setminus K)$ and $M > 0$; find a function $g \in H^p$ such that $\|g - \psi\|_{L^p(T \setminus K)} \leq M$ and $g - f$ is of minimal norm in $L^p(K)$ under this constraint.

Here ψ is a reference behavior capturing *a priori* assumptions on the behavior of the model off K , while M is some admissible deviation thereof. The value of p reflects the type of stability which is sought and how much one wants to smooth out the data. The choice of L^p classes is suited to handle pointwise measurements.

To fix terminology, we refer to (P) as a *bounded extremal problem*. As shown in [41], [44], [50], the solution to this convex infinite-dimensional optimization problem can be obtained when $p \neq 1$ upon iterating with respect to a Lagrange parameter the solution to spectral equations for appropriate Hankel and Toeplitz operators. These spectral equations involve the solution to the special case $K = T$ of (P) , which is a standard extremal problem [65]:

(P_0) Let $1 \leq p \leq \infty$ and $\varphi \in L^p(T)$; find a function $g \in H^p$ such that $g - \varphi$ is of minimal norm in $L^p(T)$.

The case $p = 1$ is more or less open.

Various modifications of (P) can be tailored to meet specific needs. For instance when dealing with lossless transfer functions (see Section 4.4), one may want to express the constraint on $T \setminus K$ in a pointwise manner: $|g - \psi| \leq M$ a.e. on $T \setminus K$, see [45], [18]. In this form, the problem comes close to (but still is different from) H^∞ frequency optimization used in control [68], [75]. One can also impose bounds on the real or imaginary part of $g - \psi$ on $T \setminus K$, which is useful when considering Dirichlet-Neumann problems, see [19].

The analog of Problem (P) on an annulus, K being now the outer boundary, can be seen as a means to regularize a classical inverse problem occurring in nondestructive control, namely to recover a harmonic function on the inner boundary from Dirichlet-Neumann data on the outer boundary (see Sections 3.2.1, 4.3, 5.1.3). It may serve as a tool to approach Bernoulli type problems, where we are given data on the outer boundary and we *seek the inner boundary*, knowing it is a level curve of the solution. In this case, the Lagrange parameter indicates how to deform the inner contour in order to improve data fitting. Similar topics are discussed in Section 3.2.1 for more general equations than the Laplacian, namely isotropic conductivity equations of the form $\operatorname{div}(\sigma \nabla u) = 0$ where σ is no longer constant. Then, the Hardy spaces in Problem (P) are those of a so-called conjugate Beltrami equation: $\bar{\partial} f = \nu \bar{\partial} f$ [69], which are studied for $1 < p < \infty$ in [5], [31], [36] and [60]. Expansions of solutions needed to constructively handle such issues in the specific case of linear fractional conductivities (occurring for instance in plasma shaping) have been expounded in [62].

Though originally considered in dimension 2, Problem (P) carries over naturally to higher dimensions where analytic functions get replaced by gradients of harmonic functions. Namely, given some open set $\Omega \subset \mathbb{R}^n$ and some \mathbb{R}^n -valued vector field V on an open subset O of the boundary of Ω , we seek a harmonic function in Ω whose gradient is close to V on O .

When Ω is a ball or a half-space, a substitute for holomorphic Hardy spaces is provided by the Stein-Weiss Hardy spaces of harmonic gradients [79]. Conformal maps are no longer available when $n > 2$, so that Ω can no longer be normalized. More general geometries than spheres and half-spaces have not been much studied so far.

On the ball, the analog of Problem (P) is

(P_1) Let $1 \leq p \leq \infty$ and $B \subset \mathbb{R}^n$ the unit ball. Fix O an open subset of the unit sphere $S \subset \mathbb{R}^n$. Let further $V \in L^p(O)$ and $W \in L^p(S \setminus O)$ be \mathbb{R}^n -valued vector fields. Given $M > 0$, find a harmonic gradient $G \in H^p(B)$ such that $\|G - W\|_{L^p(S \setminus O)} \leq M$ and $G - V$ is of minimal norm in $L^p(O)$ under this constraint.

When $p = 2$, Problem (P_1) was solved in [2] as well as its analog on a shell, when the tangent component of V is a gradient (when O is Lipschitz the general case follows easily from this). The solution extends the work in [41] to the 3-D case, using a generalization of Toeplitz operators. The case of the shell was motivated by applications to the processing of EEG data. An important ingredient is a refinement of the Hodge decomposition, that we call the *Hardy-Hodge* decomposition, allowing us to express a \mathbb{R}^n -valued vector field in $L^p(S)$, $1 < p < \infty$, as the sum of a vector field in $H^p(B)$, a vector field in $H^p(\mathbb{R}^n \setminus \bar{B})$, and a tangential divergence free vector field on S ; the space of such divergence-free fields is denoted by $D(S)$. If $p = 1$ or $p = \infty$, L^p must be replaced by the real Hardy space or the space of functions with bounded mean oscillation.

More generally this decomposition, which is valid on any sufficiently smooth surface (see Section 5.1), seems to play a fundamental role in inverse potential problems. In fact, it was first introduced formally on the plane to describe silent magnetizations supported in \mathbb{R}^2 (*i.e.* those generating no field in the upper half space) [38].

Just like solving problem (P) appeals to the solution of problem (P_0) , our ability to solve problem (P_1) will depend on the possibility to tackle the special case where $O = S$:

(P_2) Let $1 \leq p \leq \infty$ and $V \in L^p(S)$ be a \mathbb{R}^n -valued vector field. Find a harmonic gradient $G \in H^p(B)$ such that $\|G - V\|_{L^p(S)}$ is minimum.

Problem (P_2) is simple when $p = 2$ by virtue of the Hardy-Hodge decomposition together with orthogonality of $H^2(B)$ and $H^2(\mathbb{R}^n \setminus \overline{B})$, which is the reason why we were able to solve (P_1) in this case. Other values of p cannot be treated as easily and are still under investigation, especially the case $p = \infty$ which is of particular interest and presents itself as a 3-D analog to the Nehari problem [74].

Companion to problem (P_2) is problem (P_3) below.

(P_3) Let $1 \leq p \leq \infty$ and $V \in L^p(S)$ be a \mathbb{R}^n -valued vector field. Find $G \in H^p(B)$ and $D \in D(S)$ such that $\|G + D - V\|_{L^p(S)}$ is minimum.

Note that (P_2) and (P_3) are identical in 2-D, since no non-constant tangential divergence-free vector field exists on T . It is no longer so in higher dimension, where both (P_2) and (P_3) arise in connection with inverse potential problems in divergence form, like source recovery in electro/magneto encephalography and paleomagnetism, see Sections 3.2.1 and 4.3.

3.3.2. Best meromorphic and rational approximation

The techniques set forth in this section are used to solve step 2 in Section 3.2 and they are instrumental to approach inverse boundary value problems for the Poisson equation $\Delta u = \mu$, where μ is some (unknown) measure.

3.3.2.1. Scalar meromorphic and rational approximation

We put R_N for the set of rational functions with at most N poles in D . By definition, meromorphic functions in $L^p(T)$ are (traces of) functions in $H^p + R_N$.

A natural generalization of problem (P_0) is:

(P_N) Let $1 \leq p \leq \infty$, $N \geq 0$ an integer, and $f \in L^p(T)$; find a function $g_N \in H^p + R_N$ such that $g_N - f$ is of minimal norm in $L^p(T)$.

Only for $p = \infty$ and f continuous is it known how to solve (P_N) in semi-closed form. The unique solution is given by AAK theory (named after Adamjan, Arov and Krein), which connects the spectral decomposition of Hankel operators with best approximation [74].

The case where $p = 2$ is of special importance for it reduces to rational approximation. Indeed, if we write the Hardy decomposition $f = f^+ + f^-$ where $f^+ \in H^2$ and $f^- \in H^2(\mathbb{C} \setminus \overline{D})$, then $g_N = f^+ + r_N$ where r_N is a best approximant to f^- from R_N in $L^2(T)$. Moreover, r_N has no pole outside D , hence it is a *stable* rational approximant to f^- . However, in contrast to the case where $p = \infty$, this best approximant may *not* be unique.

The former Miaou project (predecessor of Apics) designed a dedicated steepest-descent algorithm for the case $p = 2$ whose convergence to a *local minimum* is guaranteed; until now it seems to be the only procedure meeting this property. This gradient algorithm proceeds recursively with respect to N on a compactification of the parameter space [33]. Although it has proved to be effective in all applications carried out so far (see Sections 4.3, 4.4), it is still unknown whether the absolute minimum can always be obtained by choosing initial conditions corresponding to *critical points* of lower degree (as is done by the RARL2 software, Section 3.4.4).

In order to establish global convergence results, Apics has undertaken a deeper study of the number and nature of critical points (local minima, saddle points, ...), in which tools from differential topology and operator theory team up with classical interpolation theory [47], [49]. Based on this work, uniqueness or asymptotic uniqueness of the approximant was proved for certain classes of functions like transfer functions of relaxation systems (*i.e.* Markov functions) [51] and more generally Cauchy integrals over hyperbolic geodesic arcs [54]. These are the only results of this kind. Research by Apics on this topic remained dormant for a while by reasons of opportunity, but revisiting the work [29] in higher dimension is a worthy and timely endeavor today. Meanwhile, an analog to AAK theory was carried out for $2 \leq p < \infty$ in [50]. Although not as effective computationally, it was recently used to derive lower bounds [4]. When $1 \leq p < 2$, problem (P_N) is still quite open.

A common feature to the above-mentioned problems is that critical point equations yield non-Hermitian orthogonality relations for the denominator of the approximant. This stresses connections with interpolation, which is a standard way to build approximants, and in many respects best or near-best rational approximation may be regarded as a clever manner to pick interpolation points. This was exploited in [55], [52], and is used in an essential manner to assess the behavior of poles of best approximants to functions with branched singularities, which is of particular interest for inverse source problems (*cf.* Sections 3.4.2 and 5.1).

In higher dimensions, the analog of Problem (P_N) is best approximation of a vector field by gradients of discrete potentials generated by N point masses. This basic issue is by no means fully understood, and it is an exciting field of research. It is connected with certain generalizations of Toeplitz or Hankel operators, and with constructive approaches to so-called weak factorizations for real Hardy functions [61].

Besides, certain constrained rational approximation problems, of special interest in identification and design of passive systems, arise when putting additional requirements on the approximant, for instance that it should be smaller than 1 in modulus (*i.e.* a Schur function). In particular, Schur interpolation lately received renewed attention from the team, in connection with matching problems. There, interpolation data are subject to a well-known compatibility condition (positive definiteness of the so-called Pick matrix), and the main difficulty is to put interpolation points on the boundary of D while controlling both the degree and the extremal points (peak points for the modulus) of the interpolant. Results obtained by Apics in this direction generalize a variant of contractive interpolation with degree constraint as studied in [66]. We mention that contractive interpolation with nodes approaching the boundary has been a subsidiary research topic by the team in the past, which plays an interesting role in the spectral representation of certain non-stationary stochastic processes [37], [40].

3.3.2.2. Matrix-valued rational approximation

Matrix-valued approximation is necessary to handle systems with several inputs and outputs but it generates additional difficulties as compared to scalar-valued approximation, both theoretically and algorithmically. In the matrix case, the McMillan degree (*i.e.* the degree of a minimal realization in the System-Theoretic sense) generalizes the usual notion of degree for rational functions. For instance when poles are simple, the McMillan degree is the sum of the ranks of the residues.

The basic problem that we consider now goes as follows: let $\mathcal{F} \in (H^2)^{m \times l}$ and n an integer; find a rational matrix of size $m \times l$ without poles in the unit disk and of McMillan degree at most n which is nearest possible to \mathcal{F} in $(H^2)^{m \times l}$. Here the L^2 norm of a matrix is the square root of the sum of the squares of the norms of its entries.

The scalar approximation algorithm derived in [33] and mentioned in Section 3.3.2.1 generalizes to the matrix-valued situation [64]. The first difficulty here is to parametrize inner matrices (*i.e.* matrix-valued functions analytic in the unit disk and unitary on the unit circle) of given McMillan degree n . Indeed, inner matrices play the role of denominators in fractional representations of transfer matrices (using the so-called Douglas-Shapiro-Shields factorization). The set of inner matrices of given degree is a smooth manifold that allows one to use differential tools as in the scalar case. In practice, one has to produce an atlas of charts (local parametrizations) and to handle changes of charts in the course of the algorithm. Such parametrization can be obtained using interpolation theory and Schur-type algorithms, the parameters of which are vectors or matrices ([27], [67], [72]). Some of these parametrizations are also interesting to compute realizations and

achieve filter synthesis ([67], [72]). The rational approximation software “RARL2” developed by the team is described in Section 3.4.4.

Difficulties relative to multiple local minima of course arise in the matrix-valued case as well, and deriving criteria that guarantee uniqueness is even more difficult than in the scalar case. The case of rational functions of degree n or small perturbations thereof (the consistency problem) was solved in [48]. Matrix-valued Markov functions are the only known example beyond this one [30].

Let us stress that RARL2 seems the only algorithm handling rational approximation in the matrix case that demonstrably converges to a local minimum while meeting stability constraints on the approximant. It is still a working pin of many developments by Apics on frequency optimization and design.

3.3.3. Behavior of poles of meromorphic approximants

Participant: Laurent Baratchart.

We refer here to the behavior of poles of best meromorphic approximants, in the L^p -sense on a closed curve, to functions f defined as Cauchy integrals of complex measures whose support lies inside the curve. Normalizing the contour to be the unit circle T , we are back to Problem (P_N) in Section 3.3.2.1; invariance of the latter under conformal mapping was established in [46]. Research so far has focused on functions whose singular set inside the contour is polar, meaning that the function can be continued analytically (possibly in a multiple-valued manner) except over a set of logarithmic capacity zero.

Generally speaking in approximation theory, assessing the behavior of poles of rational approximants is essential to obtain error rates as the degree goes large, and to tackle constructive issues like uniqueness. However, as explained in Section 3.2.1, the original twist by Apics is to consider this issue also as a means to extract information on singularities of the solution to a Dirichlet-Neumann problem. The general theme is thus: *how do the singularities of the approximant reflect those of the approximated function?* This approach to inverse problem for the 2-D Laplacian turns out to be attractive when singularities are zero- or one-dimensional (see Section 4.3). It can be used as a computationally cheap initial condition for more precise but much heavier numerical optimizations which often do not even converge unless properly initialized. As regards crack detection or source recovery, this approach boils down to analyzing the behavior of best meromorphic approximants of given pole cardinality to a function with branch points, which is the prototype of a polar singular set. For piecewise analytic cracks, or in the case of sources, we were able to prove ([6], [46], [39]), that the poles of the approximants accumulate, when the degree goes large, to some extremal cut of minimum weighted logarithmic capacity connecting the singular points of the crack, or the sources [42]. Moreover, the asymptotic density of the poles turns out to be the Green equilibrium distribution on this cut in D , therefore it charges the singular points if one is able to approximate in sufficiently high degree (this is where the method could fail, because high-order approximation requires rather precise data).

The case of two-dimensional singularities is still an outstanding open problem.

It is remarkable that inverse source problems inside a sphere or an ellipsoid in 3-D can be approached with such 2-D techniques, as applied to planar sections, see Section 5.1. The technique is implemented in the software FindSources3D, see Section 3.4.2.

3.4. Software tools of the team

In addition to the above-mentioned research activities, Apics develops and maintains a number of long-term software tools that either implement and illustrate effectiveness of the algorithms theoretically developed by the team or serve as tools to help further research by team members. We present briefly the most important of them.

3.4.1. DEDALE-HF

SCIENTIFIC DESCRIPTION

Dedale-HF consists in two parts: a database of coupling topologies as well as a dedicated predictor-corrector code. Roughly speaking each reference file of the database contains, for a given coupling topology, the complete solution to the coupling matrix synthesis problem (C.M. problem for short) associated to particular filtering characteristics. The latter is then used as a starting point for a predictor-corrector integration method that computes the solution to the C.M. corresponding to the user-specified filter characteristics. The reference files are computed off-line using Gröbner basis techniques or numerical techniques based on the exploration of a monodromy group. The use of such continuation techniques, combined with an efficient implementation of the integrator, drastically reduces the computational time.

Dedale-HF has been licensed to, and is currently used by TAS-Espana

FUNCTIONAL DESCRIPTION

Dedale-HF is a software dedicated to solve exhaustively the coupling matrix synthesis problem in reasonable time for the filtering community. Given a coupling topology, the coupling matrix synthesis problem consists in finding all possible electromagnetic coupling values between resonators that yield a realization of given filter characteristics. Solving the latter is crucial during the design step of a filter in order to derive its physical dimensions, as well as during the tuning process where coupling values need to be extracted from frequency measurements.

- Participant: Fabien Seyfert
- Contact: Fabien Seyfert
- URL: <http://www-sop.inria.fr/apics/Dedale/>

3.4.2. FindSources3D

KEYWORDS: Health - Neuroimaging - Visualization - Compilers - Medical - Image - Processing

FindSources3D is a software program dedicated to the resolution of inverse source problems in electroencephalography (EEG). From pointwise measurements of the electrical potential taken by electrodes on the scalp, FindSources3D estimates pointwise dipolar current sources within the brain in a spherical model.

After a first data transmission “cortical mapping” step, it makes use of best rational approximation on 2-D planar cross-sections and of the software RARL2 in order to locate singularities. From those planar singularities, the 3-D sources are estimated in a last step, see [7].

The present version of FindSources3D (called FindSources3D-bolis) provides a modular, ergonomic, accessible and interactive platform, with a convenient graphical interface and a tool that can be distributed and used, for EEG medical imaging. Modularity is now granted (using the tools dtk, Qt, with compiled Matlab libraries). It offers a detailed and nice visualization of data and tuning parameters, processing steps, and of the computed results (using VTK).

A new version is being developed that will incorporate a first Singular Value Decomposition (SVD) step in order to be able to handle time dependent data and to find the corresponding principal static components.

- Participants: Juliette Leblond, Maureen Clerc (team Athena, Inria Sophia), Jean-Paul Marmorat, Théodore Papadopoulos (team Athena).
- Contact: Juliette Leblond
- URL: <http://www-sop.inria.fr/apics/FindSources3D/en/index.html>

3.4.3. PRESTO-HF

SCIENTIFIC DESCRIPTION

For the matrix-valued rational approximation step, Presto-HF relies on RARL2. Constrained realizations are computed using the Dedale-HF software. As a toolbox, Presto-HF has a modular structure, which allows one for example to include some building blocks in an already existing software.

The delay compensation algorithm is based on the following assumption: far off the pass-band, one can reasonably expect a good approximation of the rational components of S_{11} and S_{22} by the first few terms of their Taylor expansion at infinity, a small degree polynomial in $1/s$. Using this idea, a sequence of quadratic convex optimization problems are solved, in order to obtain appropriate compensations. In order to check the previous assumption, one has to measure the filter on a larger band, typically three times the pass band.

This toolbox has been licensed to, and is currently used by Thales Alenia Space in Toulouse and Madrid, Thales airborne systems and Flextronics (two licenses). XLIM (University of Limoges) is a heavy user of Presto-HF among the academic filtering community and some free license agreements have been granted to the microwave department of the University of Erlangen (Germany) and the Royal Military College (Kingston, Canada).

FUNCTIONAL DESCRIPTION

Presto-HF is a toolbox dedicated to low-pass parameter identification for microwave filters. In order to allow the industrial transfer of our methods, a Matlab-based toolbox has been developed, dedicated to the problem of identification of low-pass microwave filter parameters. It allows one to run the following algorithmic steps, either individually or in a single stroke:

- Determination of delay components caused by the access devices (automatic reference plane adjustment),
- Automatic determination of an analytic completion, bounded in modulus for each channel,
- Rational approximation of fixed McMillan degree,
- Determination of a constrained realization.
 - Participants: Fabien Seyfert, Jean-Paul Marmorat and Martine Olivi
 - Contact: Fabien Seyfert
 - URL: <https://project.inria.fr/presto-hf/>

3.4.4. RARL2

Réalisation interne et Approximation Rationnelle L2

SCIENTIFIC DESCRIPTION

The method is a steepest-descent algorithm. A parametrization of MIMO systems is used, which ensures that the stability constraint on the approximant is met. The implementation, in Matlab, is based on state-space representations.

RARL2 performs the rational approximation step in the software tools PRESTO-HF and FindSources3D. It is distributed under a particular license, allowing unlimited usage for academic research purposes. It was released to the universities of Delft and Maastricht (the Netherlands), Cork (Ireland), Brussels (Belgium), Macao (China) and BITS-Pilani Hyderabad Campus (India).

FUNCTIONAL DESCRIPTION

RARL2 is a software for rational approximation. It computes a stable rational L2-approximation of specified order to a given L2-stable (L2 on the unit circle, analytic in the complement of the unit disk) matrix-valued function. This can be the transfer function of a multivariable discrete-time stable system. RARL2 takes as input either:

- its internal realization,
- its first N Fourier coefficients,
- discretized (uniformly distributed) values on the circle. In this case, a least-square criterion is used instead of the L2 norm.

It thus performs model reduction in the first or the second case, and leans on frequency data identification in the third. For band-limited frequency data, it could be necessary to infer the behavior of the system outside the bandwidth before performing rational approximation.

An appropriate Möbius transformation allows to use the software for continuous-time systems as well.

- Participants: Jean-Paul Marmorat and Martine Olivi
- Contact: Martine Olivi
- URL: <http://www-sop.inria.fr/apics/RARL2/rar12.html>

3.4.5. Sollya

KEYWORDS: Numerical algorithm - Supremum norm - Curve plotting - Remez algorithm - Code generator - Proof synthesis

FUNCTIONAL DESCRIPTION

Sollya is an interactive tool where the developers of mathematical floating-point libraries (libm) can experiment before actually developing code. The environment is safe with respect to floating-point errors, i.e. the user precisely knows when rounding errors or approximation errors happen, and rigorous bounds are always provided for these errors.

Among other features, it offers a fast Remez algorithm for computing polynomial approximations of real functions and also an algorithm for finding good polynomial approximants with floating-point coefficients to any real function. As well, it provides algorithms for the certification of numerical codes, such as Taylor Models, interval arithmetic or certified supremum norms.

It is available as a free software under the CeCILL-C license.

- Participants: Sylvain Chevillard, Christoph Lauter, Mioara Joldes and Nicolas Jourdan
- Partners: CNRS - ENS Lyon - UCBL Lyon 1
- Contact: Sylvain Chevillard
- URL: <http://sollya.gforge.inria.fr/>

4. Application Domains

4.1. Introduction

Application domains are naturally linked to the problems described in Sections 3.2.1 and 3.2.2. By and large, they split into a systems-and-circuits part and an inverse-source-and-boundary-problems part, united under a common umbrella of function-theoretic techniques as described in Section 3.3.

4.2. Inverse magnetization problems

Participants: Laurent Baratchart, Sylvain Chevillard, Juliette Leblond, Konstantinos Mavreas.

Generally speaking, inverse potential problems, similar to the one appearing in Section 4.3, occur naturally in connection with systems governed by Maxwell's equation in the quasi-static approximation regime. In particular, they arise in magnetic reconstruction issues. A specific application is to geophysics, which led us to form the Inria Associate Team IMPINGE (Inverse Magnetization Problems IN GEosciences) together with MIT and Vanderbilt University. A recent collaboration with Cerege (CNRS, Aix-en-Provence), in the framework of the ANR-project MagLune, completes this picture, see Section 7.2.2.

To set up the context, recall that the Earth's geomagnetic field is generated by convection of the liquid metallic core (geodynamo) and that rocks become magnetized by the ambient field as they are formed or after subsequent alteration. Their remanent magnetization provides records of past variations of the geodynamo, which is used to study important processes in Earth sciences like motion of tectonic plates and geomagnetic reversals. Rocks from Mars, the Moon, and asteroids also contain remanent magnetization which indicates the past presence of core dynamos. Magnetization in meteorites may even record fields produced by the young sun and the protoplanetary disk which may have played a key role in solar system formation.

For a long time, paleomagnetic techniques were only capable of analyzing bulk samples and compute their net magnetic moment. The development of SQUID microscopes has recently extended the spatial resolution to sub-millimeter scales, raising new physical and algorithmic challenges. The associate team IMPINGE aims at tackling them, experimenting with the SQUID microscope set up in the Paleomagnetism Laboratory of the department of Earth, Atmospheric and Planetary Sciences at MIT. Typically, pieces of rock are sanded down to a thin slab, and the magnetization has to be recovered from the field measured on a planar region at small distance from the slab.

Mathematically speaking, both inverse source problems for EEG from Section 4.3 and inverse magnetization problems described presently amount to recover the (3-D valued) quantity m (primary current density in case of the brain or magnetization in case of a thin slab of rock) from measurements of the potential:

$$\int_{\Omega} \frac{\operatorname{div} m(x') dx'}{|x-x'|}, \quad (1)$$

outside the volume Ω of the object. The difference is that the distribution m is located in a volume in the case of EEG, and on a plane in the case of rock magnetization. This results in quite different identifiability properties, see [38] and Section 5.1.1, but the two situations share a substantial Mathematical common core.

Another timely instance of inverse magnetization problems lies with geomagnetism. Satellites orbiting around the Earth measure the magnetic field at many points, and nowadays it is a challenge to extract global information from those measurements. In collaboration with C. Gerhards from the University of Vienna, Apics has started to work on the problem of separating the magnetic field due to the magnetization of the globe's crust from the magnetic field due to convection in the liquid metallic core. The techniques involved are variants, in a spherical context, from those developed within the IMPINGE associate team for paleomagnetism, see Section 5.1.1.

4.3. Inverse source problems in EEG

Participants: Laurent Baratchart, Juliette Leblond, Jean-Paul Marmorat, Christos Papageorgakis.

This work is conducted in collaboration with Maureen Clerc and Théo Papadopoulo from the team Athena (Inria Sophia).

Solving overdetermined Cauchy problems for the Laplace equation on a spherical layer (in 3-D) in order to extrapolate incomplete data (see Section 3.2.1) is a necessary ingredient of the team's approach to inverse source problems, in particular for applications to EEG, see [7]. Indeed, the latter involves propagating the initial conditions through several layers of different conductivities, from the boundary shell down to the center of the domain where the singularities (*i.e.* the sources) lie. Once propagated to the innermost sphere, it turns out that traces of the boundary data on 2-D cross sections coincide with analytic functions with branched singularities in the slicing plane [6], [43]. The singularities are related to the actual location of the sources, namely their moduli reach in turn a maximum when the plane contains one of the sources. Hence we are back to the 2-D framework of Section 3.3.3, and recovering these singularities can be performed *via* best rational approximation. The goal is to produce a fast and sufficiently accurate initial guess on the number and location of the sources in order to run heavier descent algorithms on the direct problem, which are more precise but computationally costly and often fail to converge if not properly initialized. Our belief is that such a localization process can add a geometric, valuable piece of information to the standard temporal analysis of EEG signal records.

Numerical experiments obtained with our software FindSources3D give very good results on simulated data and we are now engaged in the process of handling real experimental data (see Sections 3.4.2 and 5.1), in collaboration with the team Athena at Inria Sophia Antipolis, neuroscience teams in partner-hospitals (Institut de Neurosciences des Systèmes, hospital la Timone, Aix-Marseille Univ., Marseille, <http://ins.univ-amu.fr/>), and the BESA company (Munich).

4.4. Identification and design of microwave devices

Participants: Laurent Baratchart, Sylvain Chevillard, Jean-Paul Marmorat, Martine Olivi, Fabien Seyfert.

This is joint work with Stéphane Bila (XLIM, Limoges).

One of the best training grounds for function-theoretic applications by the team is the identification and design of physical systems whose performance is assessed frequency-wise. This is the case of electromagnetic resonant systems which are of common use in telecommunications.

In space telecommunications (satellite transmissions), constraints specific to on-board technology lead to the use of filters with resonant cavities in the microwave range. These filters serve multiplexing purposes (before or after amplification), and consist of a sequence of cylindrical hollow bodies, magnetically coupled by irises (orthogonal double slits). The electromagnetic wave that traverses the cavities satisfies the Maxwell equations, forcing the tangent electrical field along the body of the cavity to be zero. A deeper study of the Helmholtz equation states that an essentially discrete set of wave vectors is selected. In the considered range of frequency, the electrical field in each cavity can be decomposed along two orthogonal modes, perpendicular to the axis of the cavity (other modes are far off in the frequency domain, and their influence can be neglected).



Figure 1. Picture of a 6-cavities dual mode filter. Each cavity (except the last one) has 3 screws to couple the modes within the cavity, so that 16 quantities must be optimized. Quantities such as the diameter and length of the cavities, or the width of the 11 slits are fixed during the design phase.

Each cavity (see Figure 1) has three screws, horizontal, vertical and midway (horizontal and vertical are two arbitrary directions, the third direction makes an angle of 45 or 135 degrees, the easy case is when all cavities show the same orientation, and when the directions of the irises are the same, as well as the input and output slits). Since screws are conductors, they behave as capacitors; besides, the electrical field on the surface has to be zero, which modifies the boundary conditions of one of the two modes (for the other mode, the electrical field is zero hence it is not influenced by the screw), the third screw acts as a coupling between the two modes. The effect of an iris is opposite to that of a screw: no condition is imposed on a hole, which results in a coupling between two horizontal (or two vertical) modes of adjacent cavities (in fact the iris is the union of two rectangles, the important parameter being their width). The design of a filter consists in finding the size of each cavity, and the width of each iris. Subsequently, the filter can be constructed and tuned by adjusting the

screws. Finally, the screws are glued once a satisfactory response has been obtained. In what follows, we shall consider a typical example, a filter designed by the CNES in Toulouse, with four cavities near 11 GHz.

Near the resonance frequency, a good approximation to the Helmholtz equations is given by a second order differential equation. Thus, one obtains an electrical model of the filter as a sequence of electrically-coupled resonant circuits, each circuit being modeled by two resonators, one per mode, the resonance frequency of which represents the frequency of a mode, and whose resistance accounts for electric losses (surface currents) in the cavities.

This way, the filter can be seen as a quadripole, with two ports, when plugged onto a resistor at one end and fed with some potential at the other end. One is now interested in the power which is transmitted and reflected. This leads one to define a scattering matrix S , which may be considered as the transfer function of a stable causal linear dynamical system, with two inputs and two outputs. Its diagonal terms $S_{1,1}$, $S_{2,2}$ correspond to reflections at each port, while $S_{1,2}$, $S_{2,1}$ correspond to transmission. These functions can be measured at certain frequencies (on the imaginary axis). The matrix S is approximately rational of order 4 times the number of cavities (that is 16 in the example on Figure 2), and the key step consists in expressing the components of the equivalent electrical circuit as functions of the S_{ij} (since there are no formulas expressing the lengths of the screws in terms of parameters of this electrical model). This representation is also useful to analyze the numerical simulations of the Maxwell equations, and to check the quality of a design, in particular the absence of higher resonant modes.

In fact, resonance is not studied via the electrical model, but via a low-pass equivalent circuit obtained upon linearizing near the central frequency, which is no longer conjugate symmetric (*i.e.* the underlying system may no longer have real coefficients) but whose degree is divided by 2 (8 in the example).

In short, the strategy for identification is as follows:

- measuring the scattering matrix of the filter near the optimal frequency over twice the pass band (which is 80MHz in the example).
- Solving bounded extremal problems for the transmission and the reflection (the modulus of the response being respectively close to 0 and 1 outside the interval measurement, cf. Section 3.3.1) in order to get a model for the scattering matrix as an analytic matrix-valued function. This provides us with a scattering matrix known to be close to a rational matrix of order roughly 1/4 of the number of data points.
- Approximating this scattering matrix by a true rational transfer-function of appropriate degree (8 in this example) via the Endymion or RARL2 software (cf. Section 3.3.2.2).
- A state space realization of S , viewed as a transfer function, can then be obtained, where additional symmetry constraints coming from the reciprocity law and possibly other physical features of the device have to be imposed.
- Finally one builds a realization of the approximant and looks for a change of variables that eliminates non-physical couplings. This is obtained by using algebraic-solvers and continuation algorithms on the group of orthogonal complex matrices (symmetry forces this type of transformation).

The final approximation is of high quality. This can be interpreted as a confirmation of the linearity assumption on the system: the relative L^2 error is less than 10^{-3} . This is illustrated by a reflection diagram (Figure 2). Non-physical couplings are less than 10^{-2} .

The above considerations are valid for a large class of filters. These developments have also been used for the design of non-symmetric filters, which are useful for the synthesis of repeating devices.

The team further investigates problems relative to the design of optimal responses for microwave devices. The resolution of a quasi-convex Zolotarev problems was proposed, in order to derive guaranteed optimal multi-band filter responses subject to modulus constraints [8]. This generalizes the classical single band design techniques based on Chebyshev polynomials and elliptic functions. The approach relies on the fact that the modulus of the scattering parameter $|S_{1,2}|$ admits a simple expression in terms of the filtering function $D = |S_{1,1}|/|S_{1,2}|$, namely

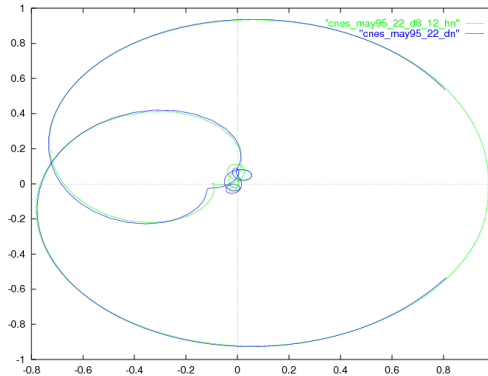

Figure 2. Nyquist Diagram. Rational approximation (degree 8) and data - S_{22} .

$$|S_{1,2}|^2 = \frac{1}{1 + D^2}.$$

The filtering function appears to be the ratio of two polynomials p_1/p_2 , the numerator of the reflection and transmission scattering factors, that may be chosen freely. The denominator q is then obtained as the unique stable unitary polynomial solving the classical Feldtkeller spectral equation:

$$qq^* = p_1p_1^* + p_2p_2^*.$$

The relative simplicity of the derivation of a filter's response, under modulus constraints, owes much to the possibility of forgetting about Feldtkeller's equation and express all design constraints in terms of the filtering function. This no longer the case when considering the synthesis N -port devices for $N > 3$, like multiplexers, routers and power dividers, or when considering the synthesis of filters under matching conditions. The efficient derivation of multiplexers responses is the subject of recent investigation by Apics, using techniques based on constrained Nevanlinna-Pick interpolation (see Section 5.2).

Through contacts with CNES (Toulouse) and UPV (Bilbao), Apics got additionally involved in the design of amplifiers which, unlike filters, are active devices. A prominent issue here is stability. A twenty years back, it was not possible to simulate unstable responses, and only after building a device could one detect instability. The advent of so-called *harmonic balance* techniques, which compute steady state responses of linear elements in the frequency domain and look for a periodic state in the time domain of a network connecting these linear elements *via* static non-linearities made it possible to compute the harmonic response of a (possibly nonlinear and unstable) device [80]. This has had tremendous impact on design, and there is a growing demand for software analyzers. The team is also becoming active in this area.

In this connection, there are two types of stability involved. The first is stability of a fixed point around which the linearized transfer function accounts for small signal amplification. The second is stability of a limit cycle which is reached when the input signal is no longer small and truly nonlinear amplification is attained (*e.g.* because of saturation). Work by the team so far has been concerned with the first type of stability, and emphasis is put on defining and extracting the “unstable part” of the response, see Section 5.3. The stability check for limit cycles is now under investigation.

5. New Results

5.1. Inverse problems for Poisson-Laplace equations

Participants: Laurent Baratchart, Sylvain Chevillard, Juliette Leblond, Jean-Paul Marmorat, Konstantinos Mavreas, Christos Papageorgakis.

5.1.1. Inverse magnetization issues from planar data

This work is carried out in the framework of the Inria Associate Team IMPINGE, comprising Cauê Borlina, Eduardo Andrade Lima and Benjamin Weiss from the Earth Sciences department at MIT (Boston, USA) and Douglas Hardin, Edward Saff and Cristobal Villalobos from the Mathematics department at Vanderbilt University (Nashville, USA).

The overall goal of IMPINGE is to determine magnetic properties of rock samples (*e.g.* meteorites or stalactites), from weak field measurements close to the sample that can nowadays be obtained using SQUIDS (superconducting quantum interference devices). Depending on the nature of the rock sample, the magnetization distribution can either be considered to lie in a plane or in a parallelepiped of thickness r . Some of our results apply to both frameworks (the former appears as a limiting case when r goes to 0), while others concern the 2D case and have no 3-D counterpart yet.

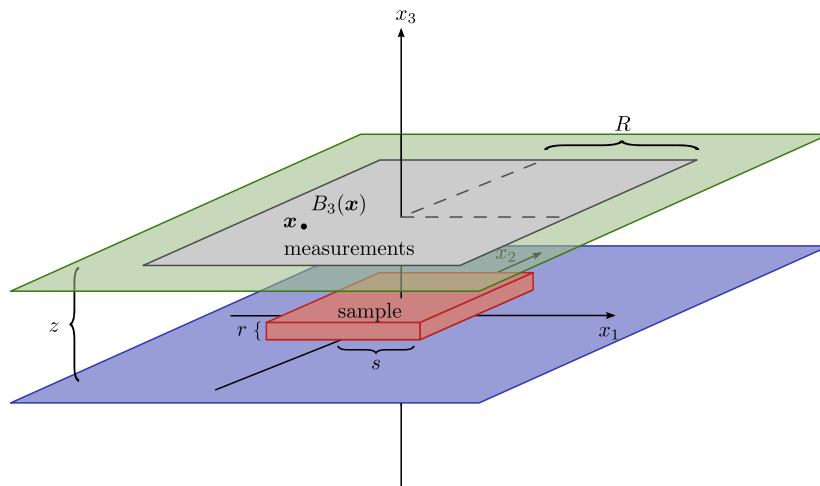

Figure 3. Schematic view of the experimental setup

Figure 3 presents a schematic view of the experimental setup: the sample lies on a horizontal plane at height 0 and its support is included in a parallelepiped. The vertical component B_3 of the field produced by the sample is measured on points of a horizontal square at height z .

We pursued this year our research efforts towards designing algorithms for net moment recovery. The net moment is the integral of the magnetization over its support, and it is a valuable piece of information to physicists which has the advantage of being determined solely by the field: whereas two different magnetizations can generate the same field, the net moment depends only on the field and not on which magnetization produced it. Hence the goal may be described as to build a numerical magnetometer, capable of analyzing data close to the sample. This is in contrast to classical magnetometers which regard the latter as a single dipole, an approximation which is only valid away from the sample and is not suitable to handle weak fields which get quickly blurred by ambient magnetic sources. This research effort was paid in two different, complementary directions.

The first approach consists in using the fact that the integral of B_3 against polynomials of order less or equal to 1 on some domains symmetric with respect to the origin provides an estimate of the net moment, asymptotically when R grows large [34]. This approach was tested this year on real data measured with the SQUID microscope at MIT. Applying directly the formulas on the measured data led to poor results, and we identified this issue as a consequence of electronic noise (drift of the measured field). This noise was impeding the method, especially when R was large, preventing one from getting estimates of the net moment with an error smaller than about 10%. By modeling this fairly deterministic drift as an affine function of the space variables, we were able to pretty much cancel out its effect. With this correction, the curve obtained when R varies follows fairly accurately the theoretical asymptotic behavior. We fit this curve with the one corresponding to the theoretical behavior, which allows us to extrapolate its value at infinity, hence giving us an estimate of the net moment. The results on some experimental data (chondrules) are promising. Yet, results on some other data sets are still unsatisfactory and remain to be understood.

The second approach attempts to generalize the previous expansions in the case when R is moderately large. This work is carried out in the thin slab framework, modeling the sample as a rectangle. Last year, we set up a bounded extremal problem (BEP, see Section 3.3.1) consisting in finding the functions ϕ_i ($i = 1, 2, 3$) such that $|\langle m_i \rangle - \iint \phi_i(x_1, x_2) B_3(x_1, x_2) dx_1 dx_2|$ is least possible under the constraint that $\|\nabla \phi_i\|_2 \leq M$, where M is a user-defined parameter. This year, we sharpened our regularity results on the solutions with respect to space variables and the parameters of the problem (e.g., the level of constraint M), and considered several resolution schemes. We implemented an algorithm approximately solving for the critical point equation, using a finite elements method. Numerical experiments on synthetic data confirm the validity of the approach with small noise, see [21]. The addition of a synthetic noise, however, has revealed sensitivity to a poor signal / noise ratio, in particular at measurement points close to the edges of the measurement slab where the estimator oscillates heavily. Such oscillations are the price to pay for an estimation procedure which uses data on a measurement set not much bigger than the sample. This is an interesting feature of the method, and further analysis is needed to offset the noise effect. Notice that the work [21] also includes perspectives on minimum L^2 regularization for the computation of local moments (which are usually not determined by the field, unlike the net moment).

We started this year to design an alternate procedure to compute a good linear estimator. It consists in expanding it on a family of piecewise affine functions, with a restricted number of pieces. This still needs to be pushed further in connection with the delicate issue of how dense should the grid of data points be in order to reach a prescribed level of precision. On a related topic, we also derived explicit formulas for the adjoint operator B_3^* to B_3 (in appropriate L^2 spaces), when applied to polynomials. This adjoint operator is central to the construction of linear estimators, and these formulas suggest one could work efficiently with polynomial bases. This work is still in progress.

Concerning full inversion of thin samples, after preliminary experiments on regularization with L^1 constraints (a heavy trend in linear inverse problems today to favor sparse solutions), we started studying magnetizations modeled by signed measures. A loop decomposition of silent sources was obtained, which makes precise in the 2-D setting the structure theorem of [78]. Moreover, a characterization of equivalent sources having minimal total variation has been obtained when the support of the magnetization is very scattered (purely 1-unrectifiable, which holds in particular for dipolar models) and also for certain magnetizations of geophysical interest like unidirectional ones. Thus, it seems that constraining the total variation to regularize the recovery process is appropriate in some important cases. The theoretical analysis has shown that the optimum is then always sparse, in that it has Hausdorff dimension at most 1. This stems from the real analyticity of operators relating the magnetization to the field, which prevents them from assuming constant level on large sets. An implementation is currently being set up with promising results. Yet, a deeper understanding on how to adjust the parameters of the method is required. This topic is studied in collaboration with D. Hardin and C. Villalobos from Vanderbilt University.

Besides, we considered a simplified 2-D setup for magnetizations and magnetic potentials (of which the magnetic field is the gradient). When both the sample and the measurement set are parallel intervals, some best approximation issues related to inverse recovery and relevant BEP problems in Hardy classes of holomorphic functions (see Section 3.3.1) were solved in [19]. Note that, in the present case, the criterion no longer acts on

the boundary of the holomorphy domain (namely, the upper half-plane), but on a strict subset thereof, while the constraint acts on the support of the approximating function. Both involve real parts of functions in the Hilbert Hardy space of the upper half-plane. This is joint work with D. Ponomarev (see Section 7.5.1). Some extensions are the subject of ongoing work with E. Pozzi (Department of Mathematics and Statistics, St Louis Univ., St Louis, Missouri, USA). They concern more precise approximation criteria, and the development of resolution schemes using the Fourier basis. Meanwhile, BEP in Bergman classes of analytic or generalized analytic functions are under being studied with B. Delgado Lopez (see Sections 3.2, 7.5.1).

For magnetizations supported in a volume Ω with boundary $\partial\Omega$, there is a greater variety of silent sources, since they have much more space to live in. Now, to each magnetization m supported in Ω there is a unique magnetization supported on $\partial\Omega$ (the balayage of m) and producing the same field outside Ω . Thus, describing silent sources supported on $\partial\Omega$ is a way to factor out some of the complexity of the situation. When m is located in the plane, the Hardy-Hodge decomposition introduced in [38] (see Section 3.3.1) was used there to characterize all silent magnetizations from above (resp. below) as being those having no harmonic gradient from below (rep. above) in their decomposition. When m is supported on a compact surface, a similar decomposition exists for \mathbb{R}^3 -valued vector fields on $\partial\Omega$, (see Section 5.4), that allows to characterize all magnetizations on $\partial\Omega$ which are silent from outside as being those whose harmonic components satisfy a certain spectral relation for the double layer potential on $\partial\Omega$. The analysis and the algorithmic use of that equation for recovery or moment estimation remain to be worked out.

Other types of inverse magnetization problems can be tackled using such techniques, in particular global Geomagnetic issues which arise in spherical geometry. This year, in collaboration with C. Gerhards from the University of Vienna (Austria), we developed a method to separate the crustal component of the Earth's magnetic field from its core component, if an estimate of the field is known on a subregion of the globe [23]. This assumption is not unrealistic: parts of Australia and of northern Europe are considered as fairly well understood from the magnetostatic view point. We look forward to test the algorithm against real data, in collaboration with Geophysicists

5.1.2. Inverse magnetization issues from sparse cylindrical data

The team Apics is a partner of the ANR project MagLune on Lunar magnetism, headed by the Geophysics and Planetology Department of Cerege, CNRS, Aix-en-Provence (see Section 7.2.2). Recent studies let geoscientists think that the Moon used to have a magnetic dynamo for a while. However, the exact process that triggered and fed this dynamo is still not understood, much less why it stopped. The overall goal of the project is to devise models to explain how this dynamo phenomenon was possible on the Moon.

The geophysicists from Cerege went a couple of times to NASA to perform measurements on a few hundreds of samples brought back from the Moon by Apollo missions. The samples are kept inside bags with a protective atmosphere, and geophysicists are not allowed to open the bags, nor to take out samples from NASA facilities. Moreover, the process must be carried out efficiently as a fee is due to NASA by the time when handling these moon samples. Therefore, measurements were performed with some specific magnetometer designed by our colleagues from Cerege. This device measures the components of the magnetic field produced by the sample, at some discrete set of points located on circles belonging to three cylinders (see Figure 4). The objective of Apics is to enhance the numerical efficiency of post-processing data obtained with this magnetometer.

This year, we continued the approach taken in previous years. Under the hypothesis that the field can be well explained by a single magnetic pointwise dipole, and using ideas similar to those underlying the FindSources3D tool (see Sections 3.4.2 and 5.1.3), we try to recover the position and the moment of the dipole using the available measurements.

In a given cylinder, using the associated cylindrical system of coordinates, recovering the position of the dipole boils down to determine its height z , its radial distance ρ and its azimuth ϕ . In principle, the rational approximation technique that we are using returns, for the circle of measurements at height h , the unique complex pole ξ_h of order five belonging to the corresponding normalized disk of some rational function. From this pole, the complex number $u_h = \xi_h + \frac{1}{\xi_h} = \frac{1+\rho^2+(h-z)^2}{\rho} e^{i\phi}$ can be estimated. In practice, due to the fact that the field is not truly generated by a single dipole, and also because of noise in the measurements and

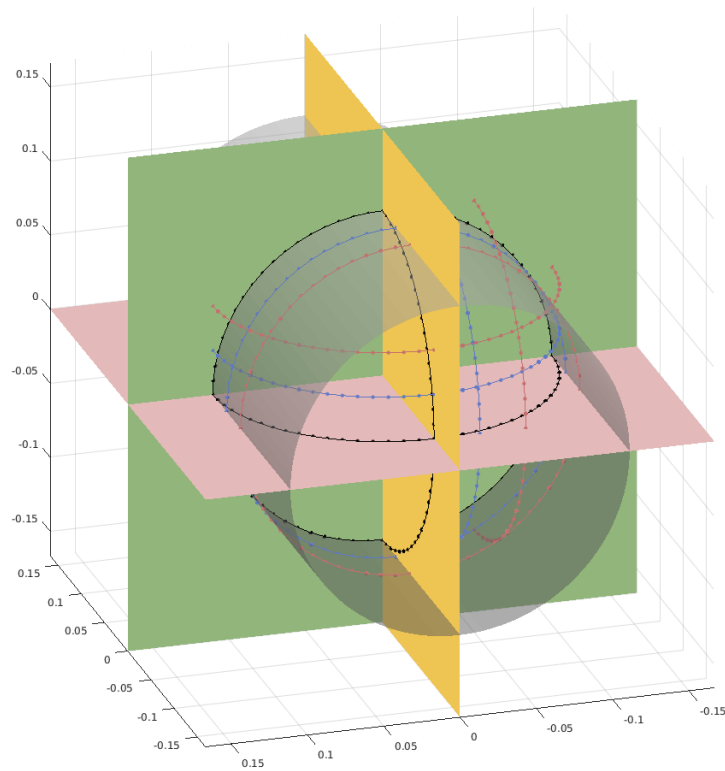

Figure 4. Typical measurements obtained with the instrument of Cerege. Measurements of the field are performed on nine circles, given as sections of three cylinders. On each circle, only one component of the field is measured: the component B_h along the axis of the corresponding cylinder (blue points), the component B_n radial with respect to the circle (black points), or the component B_τ tangential to the circle (red points).

numerical errors in the rational approximation step, only an approximation of u_h is computed. The question is then to reliably combine the information provided by all circles of measurements, in order to recover z , ρ and ϕ . The azimuth is fairly easy to obtain: we can estimate it, *e.g.*, by taking the mean value of the argument of ξ_h , for all h for which we have a measurement circle, possibly excluding one of them when the provided estimate seems to be clearly different from the others. As regards the reconstruction of ρ and z , we designed this year two new strategies.

The first strategy consists in observing that $\rho |u_h| = 1 + \rho^2 + h^2 - 2hz + z^2$, whence doing the difference with the same equation obtained at height h' : $\rho (|u_h| - |u_{h'}|) = (h^2 - h'^2) - 2(h - h')z$. This provides a linear relation between the unknowns ρ and z . Three measurement circles provide us with two independent relations and are in principle enough to recover ρ and z . Numerical experiments showed that this recovery strategy is unsatisfactory: it is fairly sensitive to approximation errors on the estimates $|u_h|$ and $|u_{h'}|$, hence the estimation procedure is unstable. However, it might become more robust if data were available on more than three circles per cylinder. Exploring this idea is an on-going piece of work. If successful, it will suggest an easy modification of the magnetometer of Cerege for future measurements campaigns.

The second strategy directly uses the pole ξ_h instead of u_h , hence avoiding numerical steps that are possible sources of errors. It consists in observing that $|\xi_h|$ is maximal, with respect to h , when $h = z$ and it is then equal to $\rho e^{i\phi}$. A rough estimate of ρ is hence given by the maximal value of $|\xi_h|$ among the three values of h available for each cylinder. The position of the dipolar source is then estimated by combining the estimates of ρ and ϕ obtained on all three cylinders. The moment is then computed from this estimated position, solving a linear system by least-squares techniques. Although not sophisticated, this method gave promising results on synthetic examples, with more or less noise, see the submitted work [25]. This is still on-going work which constitutes the main topic of the PhD thesis of K. Mavreas.

5.1.3. Inverse problems in medical imaging

This work is conducted in collaboration with Maureen Clerc and Théo Papadopoulo, from the team Athena (Inria Sophia).

In 3-D, functional or clinically active regions in the cortex are often modeled by pointwise sources that have to be localized from measurements, taken by electrodes on the scalp, of an electrical potential satisfying a Laplace equation (EEG, electroencephalography). In the works [6], [43] on the behavior of poles in best rational approximants of fixed degree to functions with branch points, it was shown how to proceed via best rational approximation on a sequence of 2-D disks cut along the inner sphere, for the case where there are finitely many sources (see Section 4.3).

In this connection, a dedicated software FindSources3D (FS3D, see Section 3.4.2) is being developed, in collaboration with the Inria team Athena and the CMA - Mines ParisTech. In addition to the modular and ergonomic platform version of FS3D, a new (Matlab) version of the software that automatically performs the estimation of the quantity of sources is being built. It uses an alignment criterion in addition to other clustering tests for the selection. It appears that, in the rational approximation step, *multiple* poles possess a nice behavior with respect to branched singularities. This is due to the very physical assumptions on the model (for EEG data that correspond to measurements of the electrical potential, one should consider *triple* poles; for (magnetic) field data however, like in Section 5.1.2 or from MEG – magneto-encephalography – data, one should consider poles of order five). Though numerically observed in [7], there is no mathematical justification so far why multiple poles generate such strong accumulation of the poles of the approximants. This intriguing property, however, is definitely helping source recovery. It is used in order to automatically estimate the “most plausible” number of sources (numerically: up to 3, at the moment). Last but not least, the version of the software currently under development takes as inputs actual EEG measurements, like time signals, and performs a suitable singular value decomposition in order to separate independent sources.

Magnetic data from MEG recently became available along with EEG data, by our medical partners at the hospital la Timone; indeed, it is now possible to use simultaneously both measurement devices, in order to measure both the electrical potential and a component of the magnetic fields. This should enhance the

accuracy of our source recovery algorithms. We will add the treatment of MEG data as another functionality of the software FS3D.

In connection with these and other brain exploration modalities like electrical impedance tomography (EIT), we are now studying conductivity estimation problems. This is the topic of the PhD research work of C. Papageorgakis (co-advised with the Inria team Athena and BESA GmbH, see Section 6.1.2). In layered models, it concerns the estimation of the conductivity of the skull (an intermediate layer). First, the conductivity of the skull can differ from one individual to another, or for the same person, along the time, and is much smaller than those of the surrounding layers (the brain and the scalp). A preliminary issue in this direction was to estimate a single-valued skull conductivity from one EEG recording. Existence, uniqueness, stability properties and a recovery scheme for this conductivity value were established in the spherical setting when the sources are known, see [10]. When the sources are unknown, we must look for additional data (additional clinical and/or functional EEG, EIT, ...) that could be incorporated in order to recover both the sources locations and the skull conductivity. Second, while the skull essentially consists of a hard bone part, which may be assumed to have constant electrical conductivity, it also contains spongy bone compartments. These two distinct components of the skull actually possess quite different conductivities. The influence of the second on the overall model is also studied in [10], together with a numerical process allowing to estimate the hard bone conductivity value together with a dipolar source, in realistic geometries.

We also began to consider the inverse problem of recovering the parameters of a skin tumor from thermal measurements, in a 2-D model that takes the form of a static Schrödinger equation. This is joint work with F. Ferranti (IMT Atlantique, Microwave Department) and the topic of the internship of G. Dervaux, see Section 7.5.1.

5.2. Matching problems and their applications

Participants: Laurent Baratchart, Martine Olivi, Gibin Bose, David Martinez Martinez, Fabien Seyfert.

This is collaborative work with Stéphane Bila (XLIM, Limoges, France), Yohann Sence (XLIM, Limoges, France), Thierry Monediere (XLIM, Limoges, France), Francois Torrès (XLIM, Limoges, France) in the context of the ANR Cocoram (see Section 7.2.1) as well as with, Fabien Ferrero (LEAT, Sophia-Antipolis, France) Leonardo Lizzi (LEAT, Sophia-Antipolis, France).

Filter synthesis is usually performed under the hypothesis that both ports of the filter are loaded on a constant resistive load (usually 50 Ohm). In complex systems, filters are however cascaded with other devices, and end up being loaded, at least at one port, on a non purely resistive frequency varying load. This is for example the case when synthesizing a multiplexer: each filter is here loaded at one of its ports on a common junction. Thus, the load varies with frequency by construction, and is not purely resistive either. Likewise, in an emitter-receiver, the antenna is followed by a filter. Whereas the antenna can usually be regarded as a resistive load at some frequencies, this is far from being true on the whole pass-band. A mismatch between the antenna and the filter, however, causes irremediable power losses, both in emission and transmission. Our goal is therefore to develop a method for filter synthesis that allows us to match varying loads on specific frequency bands, while enforcing some rejection properties away from the pass-band.

Figure 5 shows a filter with scattering matrix S , plugged at its right port on a frequency varying load with reflection parameter $L_{1,1}$. If the filter is lossless, simple algebraic manipulations show that on the frequency axis the reflex-ion parameter satisfies:

$$|G_{1,1}| = \left| \frac{S_{2,2} - \overline{L_{1,1}}}{1 - S_{2,2}L_{1,1}} \right| = \delta(G_{1,1}, S_{2,2}).$$

The matching problem of minimizing $|G_{1,1}|$ amounts therefore to minimize the pseudo-hyperbolic distance δ between the filter's reflex-ion parameter $S_{2,2}$ and the load's reflex-ion $L_{1,1}$, on a given frequency band. On the contrary enforcing a rejection level on a stop band, amounts to maintaining the value of $\delta(L_{1,1}, S_{2,2})$ above a certain threshold on this frequency band. For a broad class of filters, namely those that can be modeled by a circuit of n coupled resonators, the scattering matrix S is a rational function of McMillan degree n in

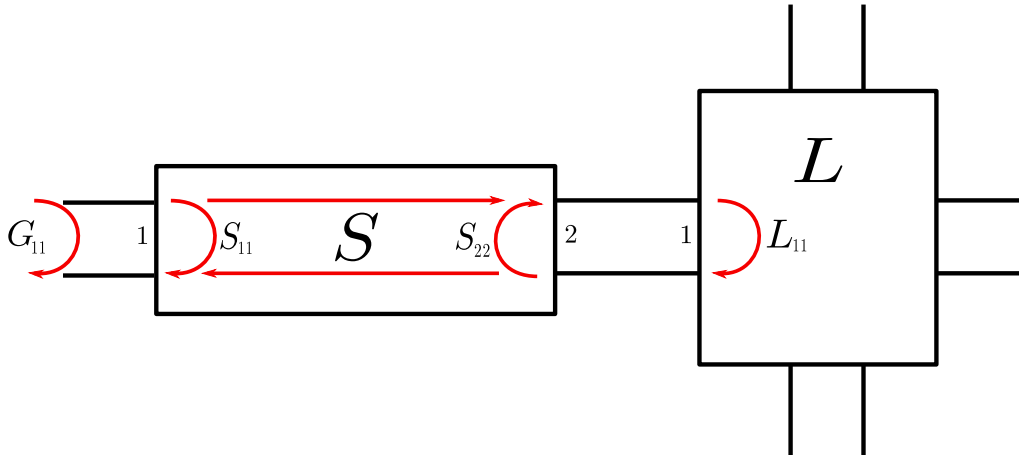

Figure 5. Filter plugged on a system with reflection coefficient L_{11}

the frequency variable. The matching problem thus appears to be a rational approximation problem in the hyperbolic metric.

5.2.1. Approach based on interpolation

When the degree n of the rational function $S_{2,2}$ is fixed, the hyperbolic minimization problem is non-convex which leads us to seek methods to derive good initial guesses for classical descent algorithms. To this effect, if $S_{2,2} = p/q$ where p, q are polynomials, we considered the following interpolation problem \mathcal{P} : given n frequency points $w_1 \cdots w_n$ and a transmission polynomial r , to find a monic polynomial p of degree n such that:

$$j = 1..n, \quad \frac{p}{q}(w_j) = \overline{L_{1,1}(w_j)}$$

where q is the unique monic Hurwitz polynomial of degree n satisfying the Feldtkeller equation

$$qq^* = pp^* + rr^*,$$

which accounts for the losslessness of the filter. The frequencies (w_k) are perfect matching points where $\delta(S_{2,2}(w_k), L_{1,1}(w_k)) = 0$ holds, while the real zeros (x_k) of r are perfect rejection points (i.e. $\delta(S_{2,2}(x_k), L_{1,1}(x_k)) = 1$). The interpolation problem is therefore a point-wise version of our original matching-rejection problem. The monic restriction on p and q ensures the realizability of the filter in terms of coupled resonating circuits. If a perfect phase shifter is added in front of the filter, realized for example with a transmission line on a narrow frequency band, these monic restrictions can be dropped and an extra interpolation point w_{n+1} is added, thereby yielding another interpolation problem $\widehat{\mathcal{P}}$. Our main result, states that \mathcal{P} as well as $\widehat{\mathcal{P}}$ admit a unique solution. Moreover the evaluation map defined by $\psi(p) = (p/q(x_1), \cdots, p/q(x_n))$ is a homeomorphism from monic polynomials of degree n onto \mathbb{D}^n (\mathbb{D} the complex open disk), and ψ^{-1} is a diffeomorphism on an open, connected, dense set of \mathbb{D}^n . This last property has shown to be crucial for the design of an effective computational procedure based on continuation techniques. Current implementations of the latter tackle instances of \mathcal{P} or $\widehat{\mathcal{P}}$ for $n = 10$ in less than 0.1 sec, and allow for a recursive use of this interpolation framework in multiplexer synthesis problems. The detailed mathematical proofs can be found in [11].

5.2.2. Uniform matching and global optimality considerations

The previous interpolation procedure provides us with a matching/rejecting filtering characteristics at a discrete set of frequencies. It can serve as a starting point for heavier optimization procedures, where the matching and rejection specifications are expressed uniformly over the bandwidth. Although the practical results thus obtained are quite convincing, we have no proof of their global optimality. This has led us to seek alternative approaches allowing us to assess, at least in simple cases, global optimality of the obtained response. By optimality of a response we mean, as in classical filtering, a best match of the response in the uniform norm on a given pass-band, while meeting given rejection constraints on a stop-band. Following the approach of Fano and Youla, we considered the problem of designing a 2×2 loss-less frequency response, under the condition that a specified load can be “unchained” from one of its port. This classically amounts to set interpolation conditions on the response at the transmission zeros of the Darlington extension of the load. When the load admits a rational representation of degree 1, and if the transmission zeros of the overall system are fixed, we were able to show that the uniform matching problem over an interval, together with rejection constraints at other frequency locations, reduces to a convex minimization problem with convex constraints over the set of non-negative polynomials of given degree. In this case, which is already of some practical interest for antenna matching (antennas usually exhibit a single resonance in their matching band which is decently approximated in degree 1), it is therefore possible to perform filter synthesis with a guarantee on the global optimality of the obtained characteristics. The constructive aspects of this approach, relying on convex duality and linear programming, were presented in [16], together with an implementation using a SIW (substrate integrated filter). For antennas with a transmission coefficient of higher degree, like dual band antennas, we developed a convex relaxation of the matching problem which yields a set lower bounds on the matching error, for every considered degree of the overall system (matching system + load). This substantially improves Helton’s approach, that furnishes a single global theoretical lower bound independent of the degree, obtained via an infinite degree H^∞ relaxation of the problem. A preliminary version of this approach was presented in [15], while a more detailed paper is under way. We consider this to be an important breakthrough concerning this classical problem in electronics. The implementation of the method involves solving a convex optimization problem on the cone of positive polynomials under some non-linear, yet convex, matrix inequality constraints. Solving the latter combining logarithmic barrier functions and Lagrangian relaxation techniques provided us, for example, with an excellent initial design for a matching network dedicated to an array of dual-band antennas with circular polarization, studied in the context of the ANR Cocoram. Design of matching networks for complex antennas is also considered in collaboration with LEAT, within the context of Gibin’s Bose PhD.

5.3. Stability assessment of microwave amplifiers and design of oscillators

Participants: Laurent Baratchart, Sylvain Chevillard, Martine Olivi, Fabien Seyfert, Sébastien Fueyo, Adam Cooman.

The goal is here to help design amplifiers, in particular to detect instability at an early stage of the design. Activity in this area is gaining importance with the coming of a doctoral (S. Fueyo) and a postdoctoral (A. Cooman) student along with planned software developments. Application of our work to oscillator design methodologies started recently with Smain Amari from the Royal Military College of Canada (Kingston, Canada).

As opposed to Filters and Antennas, Amplifiers and Oscillators are active components that intrinsically entail a non-linear functioning. The latter is due to the use of transistors governed by electric laws exhibiting saturation effects, and therefore inducing input/output characteristics that are no longer proportional to the magnitude of the input signal. Hence they typically produce non-linear distortions. A central question arising in the design of amplifiers is to assess stability. The latter may be understood around a functioning point when no input but noise is considered, or else around a periodic trajectory when an input signal at a specified frequency is applied. For oscillators, a precise estimation of their oscillating frequency is crucial during the design process. As regards devices devised to operate at relative low frequencies, time domain simulations, based on the integration of the underlying non-linear dynamical system, answers these questions satisfactorily. For

complex microwave amplifiers and oscillators, the situation is however drastically different: the time step necessary to integrate the transmission line's dynamical equations (which behave like simple electrical wire at low frequency) becomes so small that simulations are intractable in reasonable time. In addition to this problem, most linear components of these circuits are known through their frequency response, and require therefore a preliminary, numerically unstable step to obtain their impulse response, prior to any time domain simulation.

For all these reasons it is widely preferred to perform the analysis of such systems in the frequency domain. In the case of stability issues around a functioning point, where only small input signals are considered, the stability of the linearized system obtained by a first order approximation of each non-linear dynamic is considered. This is done by means of the analysis of transfer impedance functions computed at some ports of the circuit. We have shown, that under some realistic hypothesis on the building blocks of the circuit, these transfer functions are meromorphic functions of the frequency variable s , with at most a finite number of unstable poles in the right half-plane [20]. Dwelling on the unstable/stable decomposition in Hardy Spaces, we developed a procedure to assess the stability or instability of the transfer functions at hand, from their evaluation on a finite frequency grid [12]. The data are generally supplied by circuit simulators, used by microwave device designers. We are currently working towards precise estimation techniques of the unstable poles of these transfer functions, hence on the evaluation of their rational unstable part. Our approach involves here the AAK theory, furnishing at low cost a rough estimate of the desired singularities, combined with specialized versions of stable rational approximation procedures. Practical application of this work are sought among the microwave amplifier design community as well as for the synthesis of oscillators: for the latter, a precise location of one unstable poles is necessary. A software toolbox is being developed for this purposes, and a collaboration on this project has started with Smain Amari from the Royal Military College on microwave oscillator design.

When stability is studied around a periodic trajectory, which is determined in practice by Harmonic Balance algorithms, linearization yields a linear time varying dynamical system with periodic coefficients and a periodic trajectory thereof. While in finite dimension the stability of such systems is well understood via the Floquet theory, this is no longer the case in the infinite dimensional setting when delays are considered. Dwelling on the theory of retarded systems, S. Fueyo's PhD work has made remarkable progress on this topic by showing that, for certain simple circuits with properly positioned resistors, the monodromy operator is a compact perturbation of a stable operator, and that only finitely many unstable point of its spectrum can occur. A practical application of this result is to generalize the previously described techniques of stability assessment around a functioning point into a stability assessment technique around periodic trajectories. This can be recast in terms of the finiteness of the number of abscissas of unstable poles of the Harmonic Transfer functions of the circuit. It will be of great importance to generalize such considerations to more complex circuits, whose structure is less well understood at present.

5.4. The Hardy-Hodge decomposition

Participant: Laurent Baratchart.

(This is joint work with Qian T. and Dang P. from the university of Macao.) It was proven in previous year that on a smooth compact hypersurface Σ embedded in \mathbb{R}^n , a \mathbb{R}^n -valued vector field of L^p class decomposes as the sum of a harmonic gradient from inside Σ , a harmonic gradient from outside Σ , and a tangent divergence-free field. This year we extended this result to Lipschitz surfaces for $2 - \varepsilon < p < 2 + \varepsilon'$, where ε and ε' depend on the Lipschitz constant of the surface. We also proved that the decomposition is valid for $1 < p < \infty$ when Σ is VMO -smooth (*i.e.* Σ is locally the graph of Lipschitz function with derivatives in VMO). By projection onto the tangent space, this gives a Hodge decomposition for 1-forms on a Lipschitz surface, which is apparently also new since existing results deal with smooth surfaces (but forms of any degree). This result was reported at the invited session on Harmonic Analysis and Inverse Problems of the Mathematical Congress of the Americas, an article is being written to report on it.

6. Bilateral Contracts and Grants with Industry

6.1. Bilateral Contracts with Industry

6.1.1. Contract CNES-Inria-XLIM

This contract (reference Inria: 11282) accompanies the PhD of David Martinez and focuses on the development of efficient techniques for the design of matching network tailored for frequency varying loads. Applications of the latter to the design output multiplexers occurring in space applications will be considered.

6.1.2. Contract BESA GmbH-Inria

This is a research agreement between Inria (Apics and Athena teams) and the German company BESA ², which deals with head conductivity estimation and co-advising of the doctoral work of C. Papageorgakis, see Section 5.1.3. BESA is funding half of the corresponding research grant, the other half is supported by Region PACA (BDO), see Section 1.

6.1.3. Contract Inria-SKAVENJI

This is a scientific consulting activity for the start-up company SKAVENJI. The latter develops an innovative and communicative device to facilitate the production and home consumption of small amounts of energy, produced by one or more local sources of renewable energy. Ongoing work consists in designing a simple controller improving the energy efficiency of the energy production while minimizing the number of charge and discharge cycles of the associated battery. The retained control strategy is based on consumption and production profiles.

7. Partnerships and Cooperations

7.1. Regional Initiatives

- Contract Provence Alpes Côte d’Azur (PACA) Region - Inria, BDO (no. 2014-05764) funding the research grant of C. Papageorgakis, see Sections 5.1.3, 6.1.2.
- The team participates in the project WIMAG (Wave IMAGing) funded by the Idex UCA^{Jedi}. It aims at identifying and gathering the research and development by partners of UCA involved in wave imaging systems. Other partners are UNS and CNRS (GéoAzur, I3S, LEAT, LJAD), together with Orange Labs. We forecast to co-advise an internship together with members of the LEAT team ISA <http://leat.unice.fr/pages/activites/isa.html>.
- The team co-advises a PhD (G. Bose) with the CMA team of LEAT (<http://leat.unice.fr/pages/activites/cma.html>) funded by the Labex UCN@Sophia on the co-conception of Antennas and Filters.
- The team participates in the transverse action C4PO funded by the Idex UCA^{Jedi}. This “Center for Planetary Origin” brings together scientists from various fields to advance and organize Planetary Science at the the University of Nice, and supports research and teaching initiatives within its framework.
- The team also participates in the project ToMaT, “Multiscale Tomography: imaging and modeling ancient materials, technical traditions and transfers”, funded by the Idex UCA^{Jedi} (“programme structurant Matière, Lumière, Interactions”). This project brings together researchers in archaeological, physical, and mathematical sciences, with the purpose of modeling and detecting low level signals in 3D images of ancient potteries. They will co-advise together a post-doctoral researcher (starting March 2018). The concerned scientists are from CEPAM-CNRS, Nice <http://www.cepam.cnrs.fr/spip.php?article40>, the team Morpheme, CNRS-I3S-Inria <http://www.inria.fr/equipes/morpheme>, and IPANEMA, CNRS, Ministère de la Culture et de la Communication, Université Versailles Saint Quentin <http://ipanema.cnrs.fr/>.

²<http://www.besa.de/>

7.2. National Initiatives

7.2.1. ANR Cocoram

The ANR (Astrid) project Cocoram (Co-design et co-intégration de réseaux d'antennes actives multi-bandes pour systèmes de radionavigation par satellite) started January 2014. We are associated with three other teams from XLIM (Limoges University), geared respectively towards filters, antennas and amplifiers design. The core idea of the project is to realize dual band reception and emission chains by co-conceiving the antenna, the filters, and the amplifier. We are specifically in charge of the theoretical design of the filters, matching the impedance of a bi-polarized dual band antenna. This is a perfect training ground to test, apply and adapt our work on matching problems (see Section 5.2).

7.2.2. ANR MagLune

The ANR project MagLune (Magnétisme de la Lune) has been approved July 2014. It involves the Cerege (Centre de Recherche et d'Enseignement de Géosciences de l'Environnement, joint laboratory between Université Aix-Marseille, CNRS and IRD), the IPGP (Institut de Physique du Globe de Paris) and ISTERre (Institut des Sciences de la Terre). Associated with Cerege are Inria (Apics team) and Irphe (Institut de Recherche sur les Phénomènes Hors Équilibre, joint laboratory between Université Aix-Marseille, CNRS and École Centrale de Marseille). The goal of this project (led by geologists) is to understand the past magnetic activity of the Moon, especially to answer the question whether it had a dynamo in the past and which mechanisms were at work to generate it. Apics participates in the project by providing mathematical tools and algorithms to recover the remanent magnetization of rock samples from the moon on the basis of measurements of the magnetic field it generates. The techniques described in Section 5.1 are instrumental for this purpose.

7.3. European Initiatives

7.3.1. Collaborations with Major European Organizations

Apics is part of the European Research Network on System Identification (ERNSI) since 1992. System identification deals with the derivation, estimation and validation of mathematical models of dynamical phenomena from experimental data.

7.4. International Initiatives

7.4.1. Inria Associate Teams Not Involved in an Inria International Labs

7.4.1.1. IMPINGE

Title: Inverse Magnetization Problems IN GEosciences.

International Partner (Institution - Laboratory - Researcher):

Massachusetts Institute of Technology (United States) - Department of Earth, Atmospheric and Planetary Sciences - Benjamin P. Weiss

Start year: 2016

See also: <http://www-sop.inria.fr/apics/IMPINGE/>

The associate team IMPINGE is concerned with the inverse problem of recovering a magnetization distribution from measurements of the magnetic field above rock slabs using a SQUID microscope (developed at MIT). The application domain is to Earth and planetary sciences. Indeed, the remanent magnetization of rocks provides valuable information on their history. This is a renewal of the previous Associate Team IMPINGE that ended 2015. The US team also involves a group of Mathematicians at Vanderbilt University (see Section 5.1.1).

7.4.2. Inria International Partners

7.4.2.1. Informal International Partners

MIT-France seed funding is a competitive collaborative research program ran by the Massachusetts Institute of Technology (Cambridge, Ma, USA). Together with E. Lima and B. Weiss from the Earth and Planetary Sciences dept. at MIT, Apics obtained two-years support from the above-mentioned program to run a project entitled: "Development of Ultra-high Sensitivity Magnetometry for Analyzing Ancient Rock Magnetism"

NSF Grant L. Baratchart, S. Chevillard and J. Leblond are external investigators in the NSF Grant 2015-2018, “Collaborative Research: Computational methods for ultra-high sensitivity magnetometry of geological samples” led by E.B. Saff (Vanderbilt Univ.) and B. Weiss (MIT).

7.5. International Research Visitors

7.5.1. Visits of International Scientists

- Cauê Borlina (MIT, Boston, Massachusetts, USA, Apr. 24-28).
- Nattapong Bosuwan (Mahidol University, Bangkok, Thailand, May-Aug.).
- Briceyda Delgado Lopez (PhD student, Cinvestav, Queretaro, Mexico, Jan.-Mar.).
- Bernard Hanzon (Univ. Cork, Ireland, Apr.-Jun.).
- Douglas Hardin (Vanderbilt University, Nashville, Tennessee, USA, Apr. 24-28).
- Eduardo Lima (MIT, Boston, Massachusetts, USA, Apr. 24-28).
- Mateusz Rusiniak (BESA GmbH, Gräfelfing, Germany, Dec. 15).
- Ioannis Stratis (National and Kapodistrian University of Athens, Greece, Dec. 14-15).
- Carsten Wolters (University of Münster, Germany, Dec. 14-15).

7.5.1.1. Internships

- Gautier Dervaux (IMT Atlantique, Brest, France, Jul.-Aug.).

7.5.2. Visits to International Teams

7.5.2.1. Research Stays Abroad

L. Baratchart spent the fall semester 2017 at Vanderbilt University, Nashville, Tennessee, teaching a course on inverse problems and pursuing research with with D. Hardin, E.B. Saff and C. Villalobos, as well as E. Lima, all members of the Inria associate team IMPINGE

7.6. List of international and industrial partners

- Collaboration under contract with Thales Alenia Space (Toulouse, Cannes, and Paris), CNES (Toulouse), XLIM (Limoges), University of Bilbao (Universidad del País Vasco / Euskal Herriko Unibertsitatea, Spain), BESA company (Munich), Flextronics.
- Regular contacts with research groups at UST (Villeneuve d’Asq), Universities of Bordeaux-I (Talence), Orléans (MAPMO), Aix-Marseille (CMI-LATP), Nice Sophia Antipolis (Lab. JAD), Grenoble (IJF and LJK), Paris 6 (P. et M. Curie, Lab. JLL), Inria Saclay (Lab. Poems, ENSTA), IMT Atlantique (Institut Mines-Télécom., Brest), Cerege-CNRS (Aix-en-Provence), CWI (the Netherlands), MIT (Boston, USA), Vanderbilt University (Nashville USA), Steklov Institute (Moscow), Michigan State University (East-Lansing, USA), Texas A&M University (College Station USA), Indiana University-Purdue University at Indianapolis, St Louis University (St Louis, Missouri, USA), Cinvestav (Queretaro, Mexico), Politecnico di Milano (Milan, Italy), University of Trieste (Italy), RMC (Kingston, Canada), University of Leeds (UK), of Maastricht (the Netherlands), of Cork (Ireland), Vrije Universiteit Brussel (Belgium), TU-Wien and Universität Wien (Austria), TFH-Berlin (Germany), ENIT (Tunis), KTH (Stockholm), University of Cyprus (Nicosia, Cyprus), University of Macau (Macau, China), SIAE Microelettronica (Milano).
- The project is involved in the GDR-project AFHP (CNRS), in the ANR (Astrid program) project Cocoram (with XLIM, Limoges, and DGA), in the ANR (Défis de tous les savoirs program) project MagLune (with Cerege, IGP, ISTERre, Irphe), in a MIT-France collaborative seed funding, in the Associate Inria Team IMPINGE (with MIT, Boston), and in a NSF grant (with Vanderbilt University and MIT).

8. Dissemination

8.1. Promoting Scientific Activities

- L. Baratchart gave a talk at SEAM 2017 <https://www.math.utk.edu/SEAM/> and organized a scientific session at AIP 2017 <http://aip2017.csp.escience.cn/dct/page/1>.
- J. Leblond presented oral communications at the Conference “Cerveau.at.UCA”, <http://cauca2017.sciencesconf.org/>, Fréjus, France, Jun., at the Workshop ERNSI 2017, <http://ernsi2017.sciencesconf.org/>, Lyon, France Sept. and a poster at the Conference BACI 2017, <http://www.baci-conference.com/>, Bern, Switzerland, Aug.
- J.-P. Marmorat presented a poster at the 18th International Symposium on Applied Electromagnetic and Mechanics (ISEM), <http://www.isem2017.org/>, Chamonix, France, Sep.
- K. Mavreas presented oral communications at the Conference Tendances des Applications Mathématiques en Tunisie, Algérie, Maroc (TAMTAM), <http://indico.math.cnrs.fr/event/1335/overview>, Hammamet, Tunisia, May [13], at the 18th ISEM, <http://www.isem2017.org/>, Chamonix, France, Sep. [25], and at the PhD Seminar of the Research Center, Jun.
- C. Papageorgakis gave an oral communication at the Conference TAMTAM, <http://indico.math.cnrs.fr/event/1335/overview>, Hammamet, Tunisia, May [14], and at the Conference GRETSI 2017, <http://gretsi.fr/colloque2017/>, Juan-Les-Pins, France, Sep. [17].
- D. Martinez presented a poster at the International Microwave Symposium 2017 <https://ims2017.org/>, Hawaii, USA.
- G. Bose gave a talk at the International Conference on Electromagnetics in Advanced Applications <http://www.iceaa.net/j3/>, Verona, Italy, [15].
- A. Cooman presented a poster at the Workshop ERNSI 2017, <http://ernsi2017.sciencesconf.org/>, Lyon, France.
- M. Olivi gave a seminar at ONERA, Toulouse, January 12. She presented a poster at the Workshop ERNSI 2017, <http://ernsi2017.sciencesconf.org/>, Lyon, France.

8.1.1. Scientific Events Organisation

8.1.1.1. General Chair, Scientific Chair

- J. Leblond was the scientific chair of a mini-symposium at the Conference TAMTAM, <http://indico.math.cnrs.fr/event/1335/overview>, Hammamet, Tunisia, May.

8.1.1.2. Member of the Organizing Committees

- K. Mavreas was one of the organizers of the PhD seminar of the Research Center, until Oct.

8.1.2. Scientific Events Selection

8.1.2.1. Member of the Conference Program Committees

L. Baratchart was a member of the program committee of “Control and Distributed Parameter Systems”, Bordeaux, 2017.

8.1.3. Journal

8.1.3.1. Member of the Editorial Boards

L. Baratchart is an editor for “Complex Analysis and Operator Theory” (CAOT) and “Constructive Methods and Function Theory” (CMFT).

8.1.3.2. Reviewer - Reviewing Activities

S. Chevillard was a reviewer for the journal *Transactions on Computers*.

J. Leblond was a reviewer for the journals *Czechoslovak Mathematical Journal*, *Annals of West University of Timisoara - Mathematics and Computer Science*, *ESAIM: Control, Optimisation and Calculus of Variations*, *Adv. in App. Clifford Algebras*, *ARIMA*, *Numerical Algorithms*.

F. Seyfert was a reviewer for the journal *IEEE Microwave Theory and Techniques*.

M. Olivi was a reviewer for the journal *Automatica*.

8.1.4. Invited Talks

L. Baratchart was an invited speaker at the conference “Complex and Functional Analysis and their interactions with Harmonic Analysis”, Bedlewo, Poland (June) <https://plas.mat.umk.pl/etcafa/cfaha.html> and at the “Harmonic Analysis and Inverse Problems” session of the Mathematical Congress of the Americas, Montreal, Canada (Jul.) <https://mca2017.org/prog/sessions/scientific>. He was a plenary speaker at the conference “Complex and Harmonic Analysis”, Holon, Israel (June) <http://www.hit.ac.il/acc/golberga/CHA17/CHA17.html> and an invited speaker at the “Mid-western Workshop on Asymptotic Analysis”, Indianapolis, USA (October) <http://mwaa.math.iupui.edu/>, as well as an invited speaker at the conference “Mathematics, Signal Processing and Linear Systems: New Problems and Directions”, <http://www1.chapman.edu/~mbvajiac/conferences/2017Conference.html>, Chapman University, Orange, CA, USA, Nov.

J. Leblond was an invited speaker at the 17^{ème} Journée Calcul Scientifique et Modélisation Mathématique d’Amiens, <http://www.lamfa.u-picardie.fr/desveaux/JCS17/journeeCS16.html>, June, at the Conference on Control of Distributed Parameter Systems (CDPS 2017), <http://indico.math.cnrs.fr/event/1363/>, Bordeaux, July, at the annual days of GdR AFHP, <http://www.math.u-bordeaux.fr/~sgolenia/GDR/>, Bordeaux, Oct., and at the Conference Mathematics, Signal Processing and Linear Systems: New Problems and Directions, <http://www1.chapman.edu/~mbvajiac/conferences/2017Conference.html>, Chapman University, Orange, CA, USA, Nov.

M. Olivi was invited to give a communication at the symposium “Mathematics in Knowledge Engineering and Data Science - Identifying Connections”, June 30, in Maastricht, the Netherlands.

8.1.5. Scientific Expertise

F. Seyfert is a member of the IEEE MTT-8 Technical Committee on Filters and Passive Components

8.1.6. Research Administration

L. Baratchart sits on the committee “Mathématiques et Informatique” of the French Agency for research (ANR).

J. Leblond is an elected member of the “Conseil Scientifique” and of the “Commission Administrative Paritaire” of Inria. Until April, she was a member of the “Conseil Académique” of the Univ. Côte d’Azur (UCA).

8.2. Teaching - Supervision - Juries

8.2.1. Teaching

Graduate course: L. Baratchart gave a graduate course titled “Introduction to Inverse Problems” (40 hours) at Vanderbilt University, Nashville, Tennessee.

Colles: S. Chevillard is giving “Colles” at Centre International de Valbonne (CIV) (2 hours per week).

Summer School: M. Olivi gave two lectures at the 38-th summer school of automatic control, Grenoble, September 11-15: “Optimization-based model reduction” with P. Vuillemin (Onera) and “Applications in electronics: design of frequency filters and stability analysis of amplifiers”.

8.2.2. Supervision

PhD: C. Papageorgakis, *Conductivity model estimation*, since October 2014 (advisors: J. Leblond, M. Clerc, M. Rusiniak), defended Dec. 15th [10].

PhD in progress: K. Mavreas, *Inverse source problems in planetary sciences: dipole localization in Moon rocks from sparse magnetic data*, since October 2015 (advisors: S. Chevillard, J. Leblond).

PhD in progress: D. Martinez Martinez, *Méthodologie et Outils de Synthèse pour des Fonctions de Filtrage Chargées par des Impédances complexes*, since October 2015, advisors: L. Baratchart and F. Seyfert.

PhD in progress: G. Bose, *Filter Design to Match Antennas*, since December 2016, advisors: F. Ferrero and F. Seyfert.

PhD in progress: S. Fueyo, *Cycles limites et stabilité dans les circuits*, since October 2016, advisors: L. Baratchart and J.-B. Pomet.

8.2.3. Juries

L. Baratchart was a referee of the “Mémoire d’habilitation” by Nicolas Brisebarre (ENS de Lyon).

J. Leblond was a member of the “Jury d’admissibilité du concours CR2” of the Inria Research Center Nancy Grand Ouest and of the “Comité de Sélection” for professors at UNSA (Polytech Nice), in March. She was a member of the PhD thesis defense committee of Lobna Merghmi, Aix-Marseille Université, Institut de Math. de Marseille (I2M), Jan.

M. Olivi was a reviewer for the PhD document of Igor Pontes-Duff-Pereira, université de Toulouse, January 11. She was a member of the PhD thesis defense committees of Afroz Ebadat, KTH, Stockholm, September 8, and Yusuf Bhujwalla, université de Lorraine, Nancy, December 5. She was a member of the “jury d’admission du concours CR” of Inria.

8.3. Popularization

- M. Olivi is responsible for Scientific Mediation and president of the Committee MASTIC (Commission d’Animation et de Médiation Scientifique) <https://project.inria.fr/mastic/>. Her main contributions related with this mission were:
 - management of the contract “région PACA: Science Culture Lycée” and organization of about thirty conferences in the high schools of the region (100 students per conference),
 - co-organization of 10 robotics sessions for 2 classes of middle school students (device “MEDITES” <http://medites.fr>, founded by ANRU, the “Agence Nationale de Renovation Urbaine”),
 - co-organization of the “stage MathC2+”, a four-day internship for 50 high school students (“secondes”, about 16 years old) organized by the Committee MASTIC and its partners (June 14-17),
 - co-organization of Inria participation to the event “Le Village des Sciences et de l’Innovation” in Antibes (October 7 & 8, 10000 people),
 - co-organization of about 10 “cafés scientifiques” (c@fé-in’s and cafés Techno, 30 to 80 participants each),
 - supervision of a (2 months) internship, done by Sabrina Ballauris, for the realization of objects to manipulate, in view of illustrating some mathematical results and scientific principles (Pythagora’s puzzles, Galton’s board, Galileo’s experiment, the fastest toboggan, ...)

She was a member of the scientific committee of the “Forum Mathématiques Vivantes”, a national event (initiated by CFEM, the French Commission for Mathematics Education, <http://forum-maths-vivantes.fr/>) organized in Lille, Lyon, Rennes, Toulouse during the Mathematics Week. She participated into the reviewing process for the book “Panorama Mathématiques et Langages” published in this occasion by CFEM.

- M. Olivi animated two half-day workshop sessions “activités débranchées” at “l’ESPE de Nice” for primary school students (March 16 & 24), 200 students each session). She gave three presentations for high school students in Gap and Marseille. With K. Mavreas, she participates to the event “Le Village des Sciences et de l’Innovation” in Antibes (October 7 & 8, 10000 people).
- A. Cooman gave a presentation at the “stage MathC2+”, a four-day internship for high-school students organized by the Committee MASTIC and its partners (June 14-17).

9. Bibliography

Major publications by the team in recent years

- [1] S. AMARI, F. SEYFERT, M. BEKHEIT. *Theory of Coupled Resonator Microwave Bandpass Filters of Arbitrary Bandwidth*, in "Microwave Theory and Techniques, IEEE Transactions on", August 2010, vol. 58, n^o 8, pp. 2188 -2203
- [2] B. ATFEH, L. BARATCHART, J. LEBLOND, J. R. PARTINGTON. *Bounded extremal and Cauchy-Laplace problems on the sphere and shell*, in "J. Fourier Anal. Appl.", 2010, vol. 16, n^o 2, pp. 177–203, Published online Nov. 2009, <http://dx.doi.org/10.1007/s00041-009-9110-0>
- [3] L. BARATCHART, A. BORICHEV, S. CHAABI. *Pseudo-holomorphic functions at the critical exponent*, in "Journal of European Math. Soc.", 2016, vol. 18, n^o 9, pp. 1919–1960
- [4] L. BARATCHART, S. CHEVILLARD, T. QIAN. *Minimax principle and lower bounds in H^2 -rational approximation*, in "Journal of Approximation Theory", 2015, vol. 206, pp. 17–47
- [5] L. BARATCHART, J. LEBLOND, S. RIGAT, E. RUSS. *Hardy spaces of the conjugate Beltrami equation*, in "Journal of Functional Analysis", 2010, vol. 259, n^o 2, pp. 384-427, <http://dx.doi.org/10.1016/j.jfa.2010.04.004>
- [6] L. BARATCHART, H. STAHL, M. YATTSELEV. *Weighted Extremal Domains and Best Rational Approximation*, in "Advances in Mathematics", 2012, vol. 229, pp. 357-407, <http://hal.inria.fr/hal-00665834>
- [7] M. CLERC, J. LEBLOND, J.-P. MARMORAT, T. PAPADOPOULOU. *Source localization using rational approximation on plane sections*, in "Inverse Problems", May 2012, vol. 28, n^o 5, 24 p. , <http://hal.inria.fr/inria-00613644>
- [8] V. LUNOT, F. SEYFERT, S. BILA, A. NASSER. *Certified Computation of Optimal Multiband Filtering Functions*, in "IEEE Transactions on Microwave Theory and Techniques", 2008, vol. 56, n^o 1, pp. 105-112, <http://dx.doi.org/10.1109/TMTT.2007.912234>
- [9] M. OLIVI, F. SEYFERT, J.-P. MARMORAT. *Identification of microwave filters by analytic and rational H^2 approximation*, in "Automatica", January 2013, vol. 49, n^o 2, pp. 317-325 [DOI : 10.1016/J.AUTOMATICA.2012.10.005], <http://hal.inria.fr/hal-00753824>

Publications of the year

Doctoral Dissertations and Habilitation Theses

- [10] C. PAPAGEORGAKIS. *Patient specific conductivity models: characterization of the skull bones*, Université Côte d’Azur, December 2017, <https://hal.inria.fr/tel-01662075>

Articles in International Peer-Reviewed Journals

- [11] L. BARATCHART, M. OLIVI, F. SEYFERT. *Boundary nevanlinna-pick interpolation with prescribed peak points. Application to impedance matching*, in "SIAM Journal on Mathematical Analysis", 2017 [DOI : 10.1137/16M1085577], <https://hal.inria.fr/hal-01377782>
- [12] A. COOMAN, F. SEYFERT, M. OLIVI, S. CHEVILLARD, L. BARATCHART. *Model-Free Closed-Loop Stability Analysis: A Linear Functional Approach*, in "IEEE Transactions on Microwave Theory and Techniques", September 2017, <https://arxiv.org/abs/1610.03235> [DOI : 10.1109/TMTT.2017.2749222], <https://hal.inria.fr/hal-01381731>

Invited Conferences

- [13] S. CHEVILLARD, J. LEBLOND, K. MAVREAS. *Dipole localization in Moon rocks from sparse magnetic data*, in "TAMTAM2017 - Tendances des Applications Mathématiques en Tunisie, Algérie, Maroc", Hammamet, Tunisia, May 2017, <https://hal.inria.fr/hal-01526948>
- [14] M. CLERC, J. LEBLOND, J.-P. MARMORAT, C. PAPAGEORGAKIS. *Inverse conductivity recovery problem in a spherical geometry from EEG data: uniqueness, reconstruction and stability results*, in "TAMTAM 2017 - 8ème colloque, Tendances dans les Applications Mathématiques en Tunisie Algérie Maroc", Hammamet, Tunisia, May 2017, 1 p. , <https://hal.inria.fr/hal-01526931>

International Conferences with Proceedings

- [15] G. BOSE, F. FERRERO, L. LIZZI, D. MARTINEZ, F. SEYFERT. *Convex optimization for the synthesis of matching filters*, in "ICEAA 2017- International Conference on Electromagnetics in Advanced Applications", Verona, Italy, IEEE (editor), September 2017, pp. 1450-1453 [DOI : 10.1109/ICEAA.2017.8065554], <https://hal.archives-ouvertes.fr/hal-01621215>
- [16] D. MARTÍNEZ MARTÍNEZ, F. SEYFERT, M. OLIVI, S. BILA, F. TORRES, J. SENCE. *Synthesis Method for Matching Filters*, in "2017 IEEE MTT-S International Microwave Symposium (IMS)", Honolulu, United States, June 2017, pp. 1930-1933 [DOI : 10.1109/MWSYM.2017.8059040], <https://hal.archives-ouvertes.fr/hal-01420636>

Conferences without Proceedings

- [17] C. PAPAGEORGAKIS, S. HITZIGER, T. PAPADOPOULOU. *Dictionary Learning for Multidimensional Data*, in "Proceedings of GRETSI 2017", Juan-les-Pins, France, September 2017, <https://hal.inria.fr/hal-01575263>

Scientific Books (or Scientific Book chapters)

- [18] L. BARATCHART, J. LEBLOND, F. SEYFERT. *Constrained L2-approximation by polynomials on subsets of the circle*, in "New Trends in Approximation Theory. In Memory of André Boivin", J. MASHREGHI, M. MANOLAKI, P. M. GAUTHIER (editors), Fields Institute Communications, Springer, 2017, vol. 81, pp. 1-14, <https://arxiv.org/abs/1710.10808> , <https://hal.archives-ouvertes.fr/hal-01671183>
- [19] J. LEBLOND, D. PONOMAREV. *On some extremal problems for analytic functions with constraints on real or imaginary parts*, in "Advances in Complex Analysis and Operator Theory: Festschrift in Honor of Daniel Alpay's 60th Birthday", F. COLOMBO, I. SABADINI, D. C. STRUPPA, M. B. VAJIAC (editors), Birkhauser, 2017, pp. 219-236 [DOI : 10.1007/978-3-319-62362-7_8], <https://hal.archives-ouvertes.fr/hal-01623281>

Other Publications

- [20] L. BARATCHART, S. CHEVILLARD, A. COOMAN, M. OLIVI, F. SEYFERT. *Linearized Active Circuits: Transfer Functions and Stability*, December 2017, Preprint submitted to Automatica, <https://hal.inria.fr/hal-01667606>
- [21] L. BARATCHART, S. CHEVILLARD, D. P. HARDIN, J. LEBLOND, E. A. LIMA, J.-P. MARMORAT. *Magnetic moment estimation and bounded extremal problems*, October 2017, Soumis pour publication dans "Inverse problems and imaging", <https://hal.inria.fr/hal-01623991>
- [22] L. BARATCHART, P. DANG, T. QIAN. *Hardy-Hodge Decomposition of Vector Fields in R^n* , January 2017, <https://arxiv.org/abs/1702.04233> - to appear in Transactions of the American Mathematical Society, <https://hal.inria.fr/hal-01462960>
- [23] L. BARATCHART, C. GERHARDS. *On the Recovery of Core and Crustal Components of Geomagnetic Potential Fields*, March 2017, A version with minor modifications is to appear in SIAP (Vol. 77, Issue 5), <https://hal.inria.fr/hal-01486222>
- [24] A. BUREL, J. LEBLOND, B. SCHAPIRA, R. TEXIER-PICARD. *Troisième journée parité en mathématiques: Compte-rendu*, 2017, IHP, Paris, 2016. Paru dans la Gazette des Mathématiciens, SMF, <https://hal.inria.fr/hal-01631278>
- [25] S. CHEVILLARD, J. LEBLOND, K. MAVREAS. *Dipole recovery from sparse measurements of its magnetic field on a cylindrical geometry*, December 2017, This work is submitted for publication to the proceedings of the conference ISEM2017 (<http://www.isem2017.org/>), <https://hal.inria.fr/hal-01618885>

References in notes

- [26] N. I. ACHIESER. *Elements of the Theory of Elliptic Functions*, AMS, 1990
- [27] D. ALPAY, L. BARATCHART, A. GOMBANI. *On the Differential Structure of Matrix-Valued Rational Inner Functions*, in "Operator Theory : Advances and Applications", 1994, vol. 73, pp. 30–66
- [28] J. A. BALL, I. GOHBERG, L. RODMAN. *Interpolation of rational matrix functions*, Birkhäuser, 1990
- [29] L. BARATCHART. *A remark on uniqueness of best rational approximants of degree 1 in L^2 of the circle*, in "Elec. Trans.on Numerical Anal.", 2006, vol. 25, pp. 54–66
- [30] L. BARATCHART. *On the H^2 Rational Approximation of Markov Matrix-Valued Functions*, in "Proc. 17th Symposium on Mathematical Theory of Networks and Systems (MTNS)", Kyoto, Japon, 2006, pp. 180–182
- [31] L. BARATCHART, A. BORICHEV, S. CHAABI. *Pseudo-holomorphic functions at the critical exponent*, in "Journal of the European Mathematical Society", 2016, vol. 18, n^o 9 [DOI : 10.4171/JEMS], <https://hal.inria.fr/hal-00824224>
- [32] L. BARATCHART, L. BOURGEOIS, J. LEBLOND. *Uniqueness results for inverse Robin problems with bounded coefficient*, in "Journal of Functional Analysis", 2016 [DOI : 10.1016/J.JFA.2016.01.011], <https://hal.inria.fr/hal-01084428>

- [33] L. BARATCHART, M. CARDELLI, M. OLIVI. *Identification and rational L^2 approximation: a gradient algorithm*, in "Automatica", 1991, vol. 27, pp. 413–418
- [34] L. BARATCHART, S. CHEVILLARD, J. LEBLOND, E. A. LIMA, D. PONOMAREV. *Moments estimation of magnetic source terms from partial data*, 2016, working paper or preprint, <https://hal.inria.fr/hal-01421157>
- [35] L. BARATCHART, M. CHYBA, J.-B. POMET. *A Grobman-Hartman theorem for control systems*, in "J. Dyn. Differential Eqs.", 2007, vol. 19, pp. 75-107
- [36] L. BARATCHART, Y. FISCHER, J. LEBLOND. *Dirichlet/Neumann problems and Hardy classes for the planar conductivity equation*, in "Complex Variables and Elliptic Equations", 2014, 41 p. [DOI : 10.1080/17476933.2012.755755], <https://hal.archives-ouvertes.fr/hal-00909577>
- [37] L. BARATCHART, L. GOLINSKII, S. KUPIN. *Orthogonal rational functions and nonstationary stochastic processes: a Szegő theory*, in "Proc. 19th Symposium on Mathematical Theory of Networks and Systems", Budapest, 2010
- [38] L. BARATCHART, D. P. HARDIN, E. A. LIMA, E. B. SAFF, B. WEISS. *Characterizing kernels of operators related to thin-plate magnetizations via generalizations of Hodge decompositions*, in "Inverse Problems", 2013, vol. 29, n^o 1 [DOI : 10.1088/0266-5611/29/1/015004], <http://hal.inria.fr/hal-00919261>
- [39] L. BARATCHART, R. KUESTNER, V. TOTIK. *Zero distributions via orthogonality*, in "Annales de l'Institut Fourier", 2005, vol. 55, n^o 5, pp. 1455–1499
- [40] L. BARATCHART, S. KUPIN, V. LUNOT, M. OLIVI. *Multipoint Schur algorithm and orthogonal rational functions: convergence properties, I*, in "Journal d'Analyse", 2011, vol. 112, pp. 207-255, <http://arxiv.org/abs/0812.2050v3>
- [41] L. BARATCHART, J. LEBLOND. *Hardy approximation to L^p functions on subsets of the circle with $1 \leq p < \infty$* , in "Constructive Approximation", 1998, vol. 14, pp. 41–56
- [42] L. BARATCHART, J. LEBLOND, F. MANDRÉA, E. B. SAFF. *How can meromorphic approximation help to solve some 2D inverse problems for the Laplacian?*, in "Inverse Problems", 1999, vol. 15, n^o 1, pp. 79–90, <http://dx.doi.org/10.1088/0266-5611/15/1/012>
- [43] L. BARATCHART, J. LEBLOND, J.-P. MARMORAT. *Sources identification in 3D balls using meromorphic approximation in 2D disks*, in "Electronic Transactions on Numerical Analysis (ETNA)", 2006, vol. 25, pp. 41–53
- [44] L. BARATCHART, J. LEBLOND, J. R. PARTINGTON. *Hardy approximation to L^∞ functions on subsets of the circle*, in "Constructive Approximation", 1996, vol. 12, pp. 423–435
- [45] L. BARATCHART, J. LEBLOND, F. SEYFERT. *Constrained extremal problems in H_2 and Carleman's formulas*, in "Matematicheskii Sbornik", 2018, accepted for publication, <https://hal.archives-ouvertes.fr/hal-01625840>
- [46] L. BARATCHART, F. MANDRÉA, E. B. SAFF, F. WIELONSKY. *2D inverse problems for the Laplacian: a meromorphic approximation approach*, in "Journal de Math. Pures et Appliquées", 2008, vol. 86, pp. 1-41

- [47] L. BARATCHART, M. OLIVI. *Index of critical points in l^2 -approximation*, in "System and Control Letters", 1988, vol. 10, pp. 167–174
- [48] L. BARATCHART, M. OLIVI. *Critical points and error rank in best H^2 matrix rational approximation of fixed McMillan degree*, in "Constructive Approximation", 1998, vol. 14, pp. 273–300
- [49] L. BARATCHART, E. B. SAFF, F. WIELONSKY. *A criterion for uniqueness of a critical point in H^2 rational approximation*, in "Journal d'Analyse", 1996, vol. 70, pp. 225–266
- [50] L. BARATCHART, F. SEYFERT. *An L^p analog to AAK theory for $p \geq 2$* , in "Journal of Functional Analysis", 2002, vol. 191, n^o 1, pp. 52–122
- [51] L. BARATCHART, H. STAHL, F. WIELONSKY. *Asymptotic uniqueness of best rational approximants of given degree to Markov functions in L^2 of the circle*, in "Constr. Approx.", 2001, vol. 17, n^o 1, pp. 103–138
- [52] L. BARATCHART, M. YATTSELEV. *Convergent interpolation to Cauchy integrals over analytic arcs*, in "Found. Comp. Math.", 2009, vol. 9, n^o 6, pp. 675–715
- [53] L. BARATCHART, M. YATTSELEV. *Meromorphic approximants for complex Cauchy transforms with polar singularities*, in "Mat. Sbornik", 2009, vol. 200, n^o 9, pp. 3-40
- [54] L. BARATCHART, M. YATTSELEV. *Asymptotic uniqueness of best rational approximants to complex Cauchy transforms in L^2 of the circle*, in "Recent trends in orthogonal polynomials and approximation theory", Providence, RI, Contemp. Math., Amer. Math. Soc., 2010, vol. 507, pp. 87–111
- [55] L. BARATCHART, M. YATTSELEV. *Convergent Interpolation to Cauchy Integrals over Analytic Arcs with Jacobi-Type Weights*, in "International Mathematics Research Notices", 2010, vol. 2010, n^o 22, pp. 4211–4275, <http://hal.inria.fr/hal-00508314>
- [56] A. BEN ABDA, F. BEN HASSEN, J. LEBLOND, M. MAHJOUR. *Sources recovery from boundary data: a model related to electroencephalography*, in "Mathematical and Computer Modelling", 2009, vol. 49, n^o 11–12, pp. 2213–2223, <http://dx.doi.org/10.1016/j.mcm.2008.07.016>
- [57] R. CAMERON, J.-C. FAUGÈRE, F. ROUILLIER, F. SEYFERT. *Exhaustive approach to the coupling matrix synthesis problem and application to the design of high degree asymmetric filters*, in "International Journal of RF and Microwave Computer-Aided Engineering", 2007, vol. 17, n^o 1, pp. 4–12, <http://hal.inria.fr/hal-00663777>
- [58] R. CAMERON, A. HARISH, C. RADCLIFFE. *Synthesis of advanced microwave filters without diagonal cross-couplings*, in "IEEE Transactions on Microwave Theory and Techniques", dec 2002, vol. 50, n^o 12, pp. 2862–2872, <http://dx.doi.org/10.1109/TMTT.2002.805141>
- [59] S. CHAABANE, I. FELLAH, M. JAOUA, J. LEBLOND. *Logarithmic stability estimates for a Robin coefficient in 2D Laplace inverse problems*, in "Inverse Problems", 2004, vol. 20, n^o 1, pp. 49–57, <http://dx.doi.org/10.1088/0266-5611/20/1/003>
- [60] S. CHAABI. *Analyse complexe et problèmes de Dirichlet dans le plan : équation de Weinstein et autres conductivités non bornées*, Mathématiques et Informatique de Marseille, 2013

- [61] R. COIFMAN, R. ROCHBERG, G. WEISS. *Factorization theorems for Hardy spaces in several variables*, in "Ann. Math.", 1976, vol. 103, pp. 611–635
- [62] Y. FISCHER. *Approximation des des classes de fonctions analytiques généralisées et résolution de problèmes inverses pour les tokamaks*, Univ. Nice Sophia Antipolis, 2011, <http://tel.archives-ouvertes.fr/tel-00643239/>
- [63] A. FRIEDMAN, M. VOGELIUS. *Determining cracks by boundary measurements*, in "Indiana Univ. Math. J.", 1989, vol. 38, n^o 3, pp. 527–556
- [64] P. FULCHERI, M. OLIVI. *Matrix rational H^2 -approximation: a gradient algorithm based on Schur analysis*, in "SIAM J. on Control & Optim.", 1998, vol. 36, pp. 2103–2127
- [65] J. B. GARNETT. *Bounded analytic functions*, Academic Press, 1981
- [66] T. GEORGIU. *A topological approach to Nevanlinna-Pick interpolation*, in "SIAM J. Math. Anal.", 1987, vol. 18, n^o 5, pp. 1248–1260
- [67] B. HANZON, M. OLIVI, R. L. PEETERS. *Balanced realizations of discrete-time stable all-pass systems and the tangential Schur algorithm*, in "Linear Algebra and its Applications", 2006, vol. 418, pp. 793–820, <http://dx.doi.org/10.1016/j.laa.2006.09.029>
- [68] J. HELTON, D. MARSHALL. *Frequency domain analysis and analytic selections*, in "Indiana Univ. Math. J.", 1990, vol. 39, n^o 1, pp. 157–184
- [69] T. IWANIEC, G. MARTIN. *Geometric function theory and non-linear analysis*, Oxford Univ. Press, 2001
- [70] N. LANDKHOFF. *Foundations of modern potential theory*, Springer-Verlag, 1972
- [71] M. LAVRENTIEV. *Some Improperly Posed Problems of Mathematical Physics*, Springer, 1967
- [72] J.-P. MARMORAT, M. OLIVI. *Nudelman Interpolation, Parametrization of Lossless Functions and balanced realizations*, in "Automatica", 2007, vol. 43, pp. 1329–1338, <http://dx.doi.org/10.1016/j.automatica.2007.01.020>
- [73] H. ORCHARD, G. TEMES. *Filter Design Using Transformed Variables*, in "IEEE Transactions on Circuit Theory", dec 1968, vol. 15, n^o 4, pp. 385–408, <http://dx.doi.org/10.1109/TCT.1968.1082870>
- [74] V. PELLER. *Hankel Operators and their Applications*, Springer, 2003
- [75] A. SCHNECK. *Constrained Hardy space approximation*, in "J. Approx. Theory", 2010, vol. 8, pp. 1466–1483
- [76] I. SCHUR. *Über Potenzreihen die im innern des einheitskreises beschränkt sind*, in "J. Reine Angew. Math.", 1917, vol. 147, pp. 205–232
- [77] F. SEYFERT, L. BARATCHART, J.-P. MARMORAT, S. BILA, J. SOMBRIN. *Extraction of coupling parameters for microwave filters: determinati on of a stable rational model from scattering data*, in "2003 IEEE MTT-S International Microwave Symposium Digest", Philadelphie, États-Unis, IEEE, 2003, vol. 1, pp. 25–28, <http://hal.inria.fr/hal-00663504>

- [78] S. SMIRNOV. *Decomposition of solenoidal vector charges into elementary solenoids and the structure of normal one-dimensional currents*, in "Algebra i Analiz", 1993, vol. 4, pp. 206-238, Transl. St Petersburg Math. Journal, n. 4, pp. 841–867, 1994
- [79] E. M. STEIN. *Harmonic Analysis*, Princeton University Press, 1993
- [80] A. SUÀREZ, R. QUÉRÉ. *Stability analysis of nonlinear microwave circuits*, Artech House, 2003
- [81] T. WOLFF. *Counterexamples with harmonic gradients in \mathbf{R}^3* , in "Essays on Fourier analysis in honor of Elias M. Stein", Math. Ser., Princeton Univ. Press, 1995, vol. 42, pp. 321–384