



IN PARTNERSHIP WITH:
CNRS

**Université Nice - Sophia
Antipolis**

Activity Report 2017

Project-Team NACHOS

Numerical modeling and high performance computing for evolution problems in complex domains and heterogeneous media

IN COLLABORATION WITH: Laboratoire Jean-Alexandre Dieudonné (JAD)

RESEARCH CENTER
Sophia Antipolis - Méditerranée

THEME
Numerical schemes and simulations

Table of contents

1. Personnel	1
2. Overall Objectives	2
3. Research Program	3
3.1. Scientific foundations	3
3.2. High order discretization methods	4
3.2.1. The Discontinuous Galerkin method	4
3.2.2. High order DG methods for wave propagation models	4
3.3. Efficient time integration strategies	5
3.4. Numerical treatment of complex material models	6
3.5. High performance numerical computing	6
4. Application Domains	6
4.1. Electromagnetic wave propagation	6
4.1.1. Microwave interaction with biological tissues	7
4.1.2. Light/matter interaction on the nanoscale	8
4.2. Elastodynamic wave propagation	9
4.2.1. Earthquake dynamics	10
4.2.2. Seismic exploration	10
5. New Software and Platforms	10
5.1. DIOGENeS	10
5.2. GERShWIN	11
5.3. HORSE	11
6. New Results	12
6.1. Electromagnetic wave propagation	12
6.1.1. Numerical treatment of non-local dispersion for nanoplasmonics	12
6.1.2. Numerical modeling of metasurfaces	12
6.1.3. Corner effects in nanoplasmonics	13
6.1.4. Travelling waves for the non-linear Schrödinger equation in 2D	13
6.1.5. A structure preserving numerical discretization framework for the Maxwell Klein Gordon equation in 2D.	13
6.1.6. Multiscale DG methods for the time-domain Maxwell equations	13
6.1.7. HDG methods for the time-domain Maxwell equations	14
6.1.8. HDG methods for the frequency-domain Maxwell equations	14
6.1.9. HDG methods for frequency-domain plasmonics	15
6.1.10. Exponential time integrators for a DGTD method	15
6.2. Elastodynamic wave propagation	15
6.2.1. HDG method for the frequency-domain elastodynamic equations	15
6.2.2. Multiscale DG methods for the time-domain elastodynamic equations	16
6.3. High performance numerical computing	16
6.3.1. Porting a DGTD solver for bioelectromagnetics to the DEEP-ER architecture	16
6.3.2. High order HDG schemes and domain decomposition solvers for frequency-domain electromagnetics	17
6.4. Applications	17
6.4.1. Light transmission in subwavelength gratings	17
6.4.2. Light diffusion in nanostructured optical fibers	18
6.4.3. Gap-plasmon confinement with gold nanocubes	20
6.4.4. Light-trapping in nanostructured solar cells	20
7. Partnerships and Cooperations	22
7.1. National Initiatives	22
7.1.1. Inria Project Lab	22

7.1.2.	ANR project	22
7.2.	European Initiatives	23
7.2.1.1.	DEEP-ER	23
7.2.1.2.	EoCoE	23
7.2.1.3.	HPC4E	24
7.3.	International Initiatives	25
7.3.1.	Inria Associate Teams not involved in an Inria International Labs	25
7.3.2.	Inria International Partners	25
7.4.	International Research Visitors	25
7.4.1.	Visits of International Scientists	25
7.4.2.	Visits to International Teams	25
8.	Dissemination	26
8.1.	Promoting Scientific Activities	26
8.1.1.	Scientific events organisation	26
8.1.2.	Invited Talks	26
8.1.3.	Scientific Expertise	26
8.1.4.	Research Administration	26
8.2.	Teaching - Supervision - Juries	26
8.2.1.	Teaching	26
8.2.2.	Supervision	27
9.	Bibliography	27

Project-Team NACHOS

Creation of the Project-Team: 2007 July 01

Keywords:

Computer Science and Digital Science:

- A6.1.4. - Multiscale modeling
- A6.2.1. - Numerical analysis of PDE and ODE
- A6.2.7. - High performance computing

Other Research Topics and Application Domains:

- B5.3. - Nanotechnology
- B5.5. - Materials

1. Personnel

Research Scientists

Stephane Lanteri [Team leader, Inria, Senior Researcher, HDR]
Sonia Loula Fezoui [Inria, Senior Researcher]
Marie-Helene Lallemand Tenkes [Inria, Researcher]

Faculty Members

Stephane Descombes [Université Côte d'Azur, Professor, HDR]
Claire Scheid [Université Côte d'Azur, Associate Professor]

Post-Doctoral Fellow

Mostafa Javadzadeh Moghtader [Inria, from Jul 2017]

PhD Students

Alexis Gobe [Inria]
Georges Nehmetallah [Inria, from Nov 2017]
Nikolai Schmitt [Université Côte d'Azur]

Technical staff

Raphaël Léger [Inria, Engineer, until Apr 2017, granted by FP7 HPC4E project]
Ludovic Moya [Inria, Engineer, until Jun 2017, granted by FP7 PRACE-4IP project]
Jonathan Viquerat [Inria, Engineer]

Interns

Leandro Andrade Couto Fonseca [Universidade Estadual de Campinas, Sao Paulo, Brazil, from Jun 2017 until Nov 2017]
Cedric Bailly [Polytech'Nice Sophia, from Jun 2017 until Sep 2017]
Georges Nehmetallah [Université Aix-Marseille, from Apr 2017 until Sep 2017]

Administrative Assistant

Montserrat Argente [Inria]

Visiting Scientists

Liang Li [UESTC, Chengdu, China, Visiting Scientist, until Feb 2017]
Hao Wang [UESTC, Chengdu, China, Visiting PhD student, until Sep 2017]
Armel Pitelet [Université Clermont Auvergne, Visiting PhD student, Jun 2017]
Radoslaw Jurga [IIT, Lecce, Italy, Visiting PhD student, Oct 2017]
Antonio Gomes [LNCC, Petropolis, Brazil, Visiting scientist, from Jan 2017 to Feb 2017]
Wesley Da Silva Pereira [LNCC, Petropolis, Brazil, Visiting PhD student, from Sep 2017]

Frédéric Valentin [LNCC, Petropolis, Brazil, Visiting Scientist, from Dec 2016 until Feb 2017]

2. Overall Objectives

2.1. Overall objectives

The overall objectives of the NACHOS project-team are the design, mathematical analysis and actual leveraging of numerical methods for the solution of first order linear systems of partial differential equations (PDEs) with variable coefficients modeling wave propagation problems. The two main physical contexts considered by the team are electrodynamics and elastodynamics. The corresponding applications lead to the simulation of electromagnetic or seismic wave interaction with media exhibiting space and time heterogeneities. Moreover, in most of the situations of practical relevance, the propagation settings involve structures or/and material interfaces with complex shapes. Both the heterogeneity of the media and the complex geometrical features of the propagation domains motivate the use of numerical methods that can deal with non-uniform discretization meshes. In this context, the research efforts of the team concentrate on numerical methods formulated on unstructured or hybrid structured/unstructured meshes for the solution of the systems of PDEs of electrodynamics and elastodynamics. Our activities include the implementation of these numerical methods in advanced 3D simulation software that efficiently exploit the capabilities of modern high performance computing platforms. In this respect, our research efforts are also concerned with algorithmic issues related to the design of numerical algorithms that perfectly fit to the hardware characteristics of petascale class supercomputers.

In the case of electrodynamics, the mathematical model of interest is the full system of unsteady Maxwell equations [51] which is a first-order hyperbolic linear system of PDEs (if the underlying propagation media is assumed to be linear). This system can be numerically solved using so-called time-domain methods among which the Finite Difference Time-Domain (FDTD) method introduced by K.S. Yee [56] in 1996 is the most popular and which often serves as a reference method for the works of the team. For certain types of problems, a time-harmonic evolution can be assumed leading to the formulation of the frequency-domain Maxwell equations whose numerical resolution requires the solution of a linear system of equations (i.e. in that case, the numerical method is naturally implicit). Heterogeneity of the propagation media is taken into account in the Maxwell equations through the electrical permittivity, the magnetic permeability and the electric conductivity coefficients. In the general case, the electrical permittivity and the magnetic permeability are tensors whose entries depend on space (i.e. heterogeneity in space) and frequency. In the latter case, the time-domain numerical modeling of such materials requires specific techniques in order to switch from the frequency evolution of the electromagnetic coefficients to a time dependency. Moreover, there exist several mathematical models for the frequency evolution of these coefficients (Debye model, Drude model, Drude-Lorentz model, etc.).

In the case of elastodynamics, the mathematical model of interest is the system of elastodynamic equations [46] for which several formulations can be considered such as the velocity-stress system. For this system, as with Yee's scheme for time-domain electromagnetics, one of the most popular numerical method is the finite difference method proposed by J. Virieux [55] in 1986. Heterogeneity of the propagation media is taken into account in the elastodynamic equations through the Lamé and mass density coefficients. A frequency dependence of the Lamé coefficients allows to take into account physical attenuation of the wave fields and characterizes a viscoelastic material. Again, several mathematical models are available for expressing the frequency evolution of the Lamé coefficients.

3. Research Program

3.1. Scientific foundations

The research activities undertaken by the team aim at developing innovative numerical methodologies putting the emphasis on several features:

- **Accuracy.** The foreseen numerical methods should rely on discretization techniques that best fit to the geometrical characteristics of the problems at hand. Methods based on unstructured, locally refined, even non-conforming, simplicial meshes are particularly attractive in this regard. In addition, the proposed numerical methods should also be capable to accurately describe the underlying physical phenomena that may involve highly variable space and time scales. Both objectives are generally addressed by studying so-called *hp*-adaptive solution strategies which combine *h*-adaptivity using local refinement/coarsening of the mesh and *p*-adaptivity using adaptive local variation of the interpolation order for approximating the solution variables. However, for physical problems involving strongly heterogeneous or high contrast propagation media, such a solution strategy may not be sufficient. Then, for dealing accurately with these situations, one has to design numerical methods that specifically address the multiscale nature of the underlying physical phenomena.
- **Numerical efficiency.** The simulation of unsteady problems most often relies on explicit time integration schemes. Such schemes are constrained by a stability criterion, linking some space and time discretization parameters, that can be very restrictive when the underlying mesh is highly non-uniform (especially for locally refined meshes). For realistic 3D problems, this can represent a severe limitation with regards to the overall computing time. One possible overcoming solution consists in resorting to an implicit time scheme in regions of the computational domain where the underlying mesh size is very small, while an explicit time scheme is applied elsewhere in the computational domain. The resulting hybrid explicit-implicit time integration strategy raises several challenging questions concerning both the mathematical analysis (stability and accuracy, especially for what concern numerical dispersion), and the computer implementation on modern high performance systems (data structures, parallel computing aspects). A second, often considered approach is to devise a local time stepping strategy. Beside, when considering time-harmonic (frequency-domain) wave propagation problems, numerical efficiency is mainly linked to the solution of the system of algebraic equations resulting from the discretization in space of the underlying PDE model. Various strategies exist ranging from the more robust and efficient sparse direct solvers to the more flexible and cheaper (in terms of memory resources) iterative methods. Current trends tend to show that the ideal candidate will be a judicious mix of both approaches by relying on domain decomposition principles.
- **Computational efficiency.** Realistic 3D wave propagation problems involve the processing of very large volumes of data. The latter results from two combined parameters: the size of the mesh i.e the number of mesh elements, and the number of degrees of freedom per mesh element which is itself linked to the degree of interpolation and to the number of physical variables (for systems of partial differential equations). Hence, numerical methods must be adapted to the characteristics of modern parallel computing platforms taking into account their hierarchical nature (e.g multiple processors and multiple core systems with complex cache and memory hierarchies). In addition, appropriate parallelization strategies need to be designed that combine SIMD and MIMD programming paradigms.

From the methodological point of view, the research activities of the team are concerned with four main topics: (1) high order finite element type methods on unstructured or hybrid structured/unstructured meshes for the discretization of the considered systems of PDEs, (2) efficient time integration strategies for dealing with grid induced stiffness when using non-uniform (locally refined) meshes, (3) numerical treatment of complex propagation media models (e.g. physical dispersion models), (4) algorithmic adaptation to modern high performance computing platforms.

3.2. High order discretization methods

3.2.1. *The Discontinuous Galerkin method*

The Discontinuous Galerkin method (DG) was introduced in 1973 by Reed and Hill to solve the neutron transport equation. From this time to the 90's a review on the DG methods would likely fit into one page. In the meantime, the Finite Volume approach (FV) has been widely adopted by computational fluid dynamics scientists and has now nearly supplanted classical finite difference and finite element methods in solving problems of non-linear convection and conservation law systems. The success of the FV method is due to its ability to capture discontinuous solutions which may occur when solving non-linear equations or more simply, when convecting discontinuous initial data in the linear case. Let us first remark that DG methods share with FV methods this property since a first order FV scheme may be viewed as a 0th order DG scheme. However a DG method may also be considered as a Finite Element (FE) one where the continuity constraint at an element interface is released. While keeping almost all the advantages of the FE method (large spectrum of applications, complex geometries, etc.), the DG method has other nice properties which explain the renewed interest it gains in various domains in scientific computing as witnessed by books or special issues of journals dedicated to this method [43]- [44]- [45]- [50]:

- It is naturally adapted to a high order approximation of the unknown field. Moreover, one may increase the degree of the approximation in the whole mesh as easily as for spectral methods but, with a DG method, this can also be done very locally. In most cases, the approximation relies on a polynomial interpolation method but the DG method also offers the flexibility of applying local approximation strategies that best fit to the intrinsic features of the modeled physical phenomena.
- When the space discretization is coupled to an explicit time integration scheme, the DG method leads to a block diagonal mass matrix whatever the form of the local approximation (e.g. the type of polynomial interpolation). This is a striking difference with classical, continuous FE formulations. Moreover, the mass matrix may be diagonal if the basis functions are orthogonal.
- It easily handles complex meshes. The grid may be a classical conforming FE mesh, a non-conforming one or even a hybrid mesh made of various elements (tetrahedra, prisms, hexahedra, etc.). The DG method has been proven to work well with highly locally refined meshes. This property makes the DG method more suitable (and flexible) to the design of some hp -adaptive solution strategy.
- It is also flexible with regards to the choice of the time stepping scheme. One may combine the DG spatial discretization with any global or local explicit time integration scheme, or even implicit, provided the resulting scheme is stable.
- It is naturally adapted to parallel computing. As long as an explicit time integration scheme is used, the DG method is easily parallelized. Moreover, the compact nature of DG discretization schemes is in favor of high computation to communication ratio especially when the interpolation order is increased.

As with standard FE methods, a DG method relies on a variational formulation of the continuous problem at hand. However, due to the discontinuity of the global approximation, this variational formulation has to be defined locally, at the element level. Then, a degree of freedom in the design of a DG method stems from the approximation of the boundary integral term resulting from the application of an integration by parts to the element-wise variational form. In the spirit of FV methods, the approximation of this boundary integral term calls for a numerical flux function which can be based on either a centered scheme or an upwind scheme, or a blending between these two schemes.

3.2.2. *High order DG methods for wave propagation models*

DG methods are at the heart of the activities of the team regarding the development of high order discretization schemes for the PDE systems modeling electromagnetic and elastodynamic wave propagation.

- **Nodal DG methods for time-domain problems.** For the numerical solution of the time-domain Maxwell equations, we have first proposed a non-dissipative high order DGTD (Discontinuous Galerkin Time-Domain) method working on unstructured conforming simplicial meshes [13]. This DG method combines a central numerical flux function for the approximation of the integral term at the interface of two neighboring elements with a second order leap-frog time integration scheme. Moreover, the local approximation of the electromagnetic field relies on a nodal (Lagrange type) polynomial interpolation method. Recent achievements by the team deal with the extension of these methods towards non-conforming unstructured [10]-[11] and hybrid structured/unstructured meshes [6], their coupling with hybrid explicit/implicit time integration schemes in order to improve their efficiency in the context of locally refined meshes [4]-[20]-[19]. A high order DG method has also been proposed for the numerical resolution of the elastodynamic equations modeling the propagation of seismic waves [2]-[9].
- **Hybridizable DG (HDG) method for time-domain and time-harmonic problems.** For the numerical treatment of the time-harmonic Maxwell equations, nodal DG methods can also be considered [8]. However, such DG formulations are highly expensive, especially for the discretization of 3D problems, because they lead to a large sparse and indefinite linear system of equations coupling all the degrees of freedom of the unknown physical fields. Different attempts have been made in the recent past to improve this situation and one promising strategy has been recently proposed by Cockburn *et al.*[48] in the form of so-called hybridizable DG formulations. The distinctive feature of these methods is that the only globally coupled degrees of freedom are those of an approximation of the solution defined only on the boundaries of the elements. This work is concerned with the study of such Hybridizable Discontinuous Galerkin (HDG) methods for the solution of the system of Maxwell equations in the time-domain when the time integration relies on an implicit scheme, or in the frequency-domain. The team has been a precursor in the development of HDG methods for the frequency-domain Maxwell equations [16]-[17].
- **Multiscale DG methods for time-domain problems.** More recently, in collaboration with LNCC in Petropolis (Frédéric Valentin) the framework of the HOMAR associate team, we are investigating a family of methods specifically designed for an accurate and efficient numerical treatment of multiscale wave propagation problems. These methods, referred to as Multiscale Hybrid Mixed (MHM) methods, are currently studied in the team for both time-domain electromagnetic and elastodynamic PDE models. They consist in reformulating the mixed variational form of each system into a global (arbitrarily coarse) problem related to a weak formulation of the boundary condition (carried by a Lagrange multiplier that represents e.g. the normal stress tensor in elastodynamic systems), and a series of small, element-wise, fully decoupled problems resembling to the initial one and related to some well chosen partition of the solution variables on each element. By construction, that methodology is fully parallelizable and recursivity may be used in each local problem as well, making MHM methods belonging to multi-level highly parallelizable methods. Each local problem may be solved using DG or classical Galerkin FE approximations combined with some appropriate time integration scheme (θ -scheme or leap-frog scheme).

3.3. Efficient time integration strategies

The use of unstructured meshes (based on triangles in two space dimensions and tetrahedra in three space dimensions) is an important feature of the DGTD methods developed in the team which can thus easily deal with complex geometries and heterogeneous propagation media. Moreover, DG discretization methods are naturally adapted to local, conforming as well as non-conforming, refinement of the underlying mesh. Most of the existing DGTD methods rely on explicit time integration schemes and lead to block diagonal mass matrices which is often recognized as one of the main advantages with regards to continuous finite element methods. However, explicit DGTD methods are also constrained by a stability condition that can be very restrictive on highly refined meshes and when the local approximation relies on high order polynomial interpolation. There are basically three strategies that can be considered to cure this computational efficiency problem. The first approach is to use an unconditionally stable implicit time integration scheme to overcome the restrictive

constraint on the time step for locally refined meshes. In a second approach, a local time stepping strategy is combined with an explicit time integration scheme. In the third approach, the time step size restriction is overcome by using a hybrid explicit-implicit procedure. In this case, one blends a time implicit and a time explicit schemes where only the solution variables defined on the smallest elements are treated implicitly. The first and third options are considered in the team in the framework of DG [4]-[20]-[19] and HDG discretization methods.

3.4. Numerical treatment of complex material models

Towards the general aim of being able to consider concrete physical situations, we are interested in taking into account in the numerical methodologies that we study, a better description of the propagation of waves in realistic media. In the case of electromagnetics, a typical physical phenomenon that one has to consider is *dispersion*. It is present in almost all media and expresses the way the material reacts to an electromagnetic field. In the presence of an electric field a medium does not react instantaneously and thus presents an electric polarization of the molecules or electrons that itself influences the electric displacement. In the case of a linear homogeneous isotropic media, there is a linear relation between the applied electric field and the polarization. However, above some range of frequencies (depending on the considered material), the dispersion phenomenon cannot be neglected and the relation between the polarization and the applied electric field becomes complex. This is rendered via a frequency-dependent complex permittivity. Several models of complex permittivity exist. Concerning biological media, the Debye model is commonly adopted in the presence of water, biological tissues and polymers, so that it already covers a wide range of applications [15]. In the context of nanoplasmonics, one is interested in modeling the dispersion effects on metals on the nanometer scale and at optical frequencies. In this case, the Drude or the Drude-Lorentz models are generally chosen [22]. In the context of seismic wave propagation, we are interested by the intrinsic attenuation of the medium [21]. In realistic configurations, for instance in sedimentary basins where the waves are trapped, we can observe site effects due to local geological and geotechnical conditions which result in a strong increase in amplification and duration of the ground motion at some particular locations. During the wave propagation in such media, a part of the seismic energy is dissipated because of anelastic losses related to the internal friction of the medium. For these reasons, numerical simulations based on the basic assumption of linear elasticity are no more valid since this assumption results in a severe overestimation of amplitude and duration of the ground motion, even when we are not in presence of a site effect, since intrinsic attenuation is not taken into account.

3.5. High performance numerical computing

Beside basic research activities related to the design of numerical methods and resolution algorithms for the wave propagation models at hand, the team is also committed to demonstrate the benefits of the proposed numerical methodologies in the simulation of challenging three-dimensional problems pertaining to computational electromagnetics and computational geoseismics. For such applications, parallel computing is a mandatory path. Nowadays, modern parallel computers most often take the form of clusters of heterogeneous multiprocessor systems, combining multiple core CPUs with accelerator cards (e.g Graphical Processing Units - GPUs), with complex hierarchical distributed-shared memory systems. Developing numerical algorithms that efficiently exploit such high performance computing architectures raises several challenges, especially in the context of a massive parallelism. In this context, current efforts of the team are towards the exploitation of multiple levels of parallelism (computing systems combining CPUs and GPUs) through the study of hierarchical SPMD (Single Program Multiple Data) strategies for the parallelization of unstructured mesh based solvers.

4. Application Domains

4.1. Electromagnetic wave propagation

Electromagnetic devices are ubiquitous in present day technology. Indeed, electromagnetism has found and continues to find applications in a wide array of areas, encompassing both industrial and societal purposes. Applications of current interest include (among others) those related to communications (e.g transmission through optical fiber lines), to biomedical devices (e.g microwave imaging, micro-antenna design for telemedicine, etc.), to circuit or magnetic storage design (electromagnetic compatibility, hard disc operation), to geophysical prospecting, and to non-destructive evaluation (e.g crack detection), to name but just a few. Equally notable and motivating are applications in defence which include the design of military hardware with decreased signatures, automatic target recognition (e.g bunkers, mines and buried ordnance, etc.) propagation effects on communication and radar systems, etc. Although the principles of electromagnetics are well understood, their application to practical configurations of current interest, such as those that arise in connection with the examples above, is significantly complicated and far beyond manual calculation in all but the simplest cases. These complications typically arise from the geometrical characteristics of the propagation medium (irregular shapes, geometrical singularities), the physical characteristics of the propagation medium (heterogeneity, physical dispersion and dissipation) and the characteristics of the sources (wires, etc.).

Although many of the above-mentioned application contexts can potentially benefit from numerical modeling studies, the team currently concentrates its efforts on two physical situations.

4.1.1. Microwave interaction with biological tissues

Two main reasons motivate our commitment to consider this type of problem for the application of the numerical methodologies developed in the NACHOS project-team:

- First, from the numerical modeling point of view, the interaction between electromagnetic waves and biological tissues exhibit the three sources of complexity identified previously and are thus particularly challenging for pushing one step forward the state-of-the art of numerical methods for computational electromagnetics. The propagation media is strongly heterogeneous and the electromagnetic characteristics of the tissues are frequency dependent. Interfaces between tissues have rather complicated shapes that cannot be accurately discretized using cartesian meshes. Finally, the source of the signal often takes the form of a complicated device (e.g a mobile phone or an antenna array).
- Second, the study of the interaction between electromagnetic waves and living tissues is of interest to several applications of societal relevance such as the assessment of potential adverse effects of electromagnetic fields or the utilization of electromagnetic waves for therapeutic or diagnostic purposes. It is widely recognized nowadays that numerical modeling and computer simulation of electromagnetic wave propagation in biological tissues is a mandatory path for improving the scientific knowledge of the complex physical mechanisms that characterize these applications.

Despite the high complexity both in terms of heterogeneity and geometrical features of tissues, the great majority of numerical studies so far have been conducted using variants of the widely known FDTD method due to Yee [56]. In this method, the whole computational domain is discretized using a structured (cartesian) grid. Due to the possible straightforward implementation of the algorithm and the availability of computational power, FDTD is currently the leading method for numerical assessment of human exposure to electromagnetic waves. However, limitations are still seen, due to the rather difficult departure from the commonly used rectilinear grid and cell size limitations regarding very detailed structures of human tissues. In this context, the general objective of the contributions of the NACHOS project-team is to demonstrate the benefits of high order unstructured mesh based Maxwell solvers for a realistic numerical modeling of the interaction of electromagnetic waves and biological tissues with emphasis on applications related to numerical dosimetry. Since the creation of the team, our works on this topic have mainly been focussed on the study of the exposure of humans to radiations from mobile phones or wireless communication systems (see Fig. 1). This activity has been conducted in close collaboration with the team of Joe Wiart at Orange Labs/Whist Laboratory <http://whist.institut-telecom.fr/en/index.html> (formerly, France Telecom Research & Development) in Issy-les-Moulineaux [12].

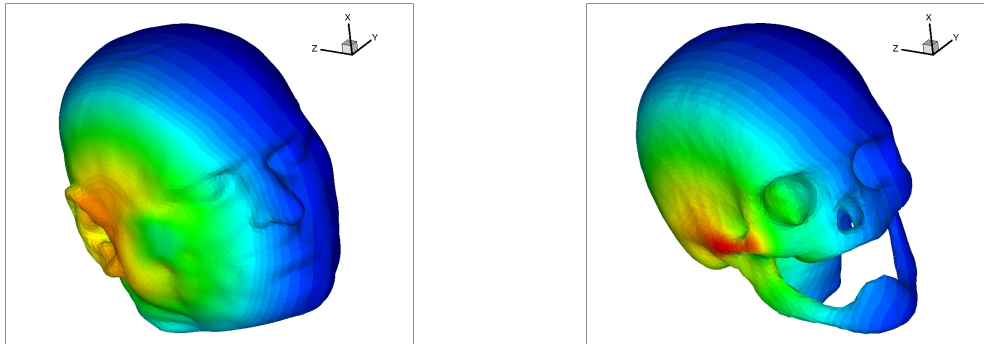

Figure 1. Exposure of head tissues to an electromagnetic wave emitted by a localized source. Top figures: surface triangulations of the skin and the skull. Bottom figures: contour lines of the amplitude of the electric field.

4.1.2. Light/matter interaction on the nanoscale

Nanostructuring of materials has opened up a number of new possibilities for manipulating and enhancing light-matter interactions, thereby improving fundamental device properties. Low-dimensional semiconductors, like quantum dots, enable one to catch the electrons and control the electronic properties of a material, while photonic crystal structures allow to synthesize the electromagnetic properties. These technologies may, e.g., be employed to make smaller and better lasers, sources that generate only one photon at a time, for applications in quantum information technology, or miniature sensors with high sensitivity. The incorporation of metallic structures into the medium add further possibilities for manipulating the propagation of electromagnetic waves. In particular, this allows subwavelength localisation of the electromagnetic field and, by subwavelength structuring of the material, novel effects like negative refraction, e.g. enabling super lenses, may be realized. Nanophotonics is the recently emerged, but already well defined, field of science and technology aimed at establishing and using the peculiar properties of light and light-matter interaction in various nanostructures. Nanophotonics includes all the phenomena that are used in optical sciences for the development of optical devices. Therefore, nanophotonics finds numerous applications such as in optical microscopy, the design of optical switches and electromagnetic chips circuits, transistor filaments, etc. Because of its numerous scientific and technological applications (e.g. in relation to telecommunication, energy production and biomedicine), nanophotonics represents an active field of research increasingly relying on numerical modeling beside experimental studies.

Plasmonics is a related field to nanophotonics. Metallic nanostructures whose optical scattering is dominated by the response of the conduction electrons are considered as plasmomic media. If the structure presents an interface with e.g. a dielectric with a positive permittivity, collective oscillations of surface electrons create surface-plasmons-polaritons (SPPs) that propagate along the interface. SPPs are guided along metal-dielectric interfaces much in the same way light can be guided by an optical fiber, with the unique characteristic of subwavelength-scale confinement perpendicular to the interface. Nanofabricated systems that exploit SPPs offer fascinating opportunities for crafting and controlling the propagation of light in matter. In particular, SPPs can be used to channel light efficiently into nanometer-scale volumes, leading to direct modification of mode dispersion properties (substantially shrinking the wavelength of light and the speed of light pulses for example), as well as huge field enhancements suitable for enabling strong interactions with non-linear materials. The resulting enhanced sensitivity of light to external parameters (for example, an applied electric field or the dielectric constant of an adsorbed molecular layer) shows great promise for applications in sensing and switching. In particular, very promising applications are foreseen in the medical domain [49]- [57].

Numerical modeling of electromagnetic wave propagation in interaction with metallic nanostructures at optical frequencies requires to solve the system of Maxwell equations coupled to appropriate models of physical dispersion in the metal, such as the Drude and Drude-Lorentz models. Here again, the FDTD method is a widely used approach for solving the resulting system of PDEs [54]. However, for nanophotonic applications, the space and time scales, in addition to the geometrical characteristics of the considered nanostructures (or structured layouts of the latter), are particularly challenging for an accurate and efficient application of the FDTD method. Recently, unstructured mesh based methods have been developed and have demonstrated their potentialities for being considered as viable alternatives to the FDTD method [52]- [53]- [47]. Since the end of 2012, nanophotonics/plasmonics is increasingly becoming a focused application domain in the research activities of the team in close collaboration with physicists from CNRS laboratories, and also with researchers from international institutions.

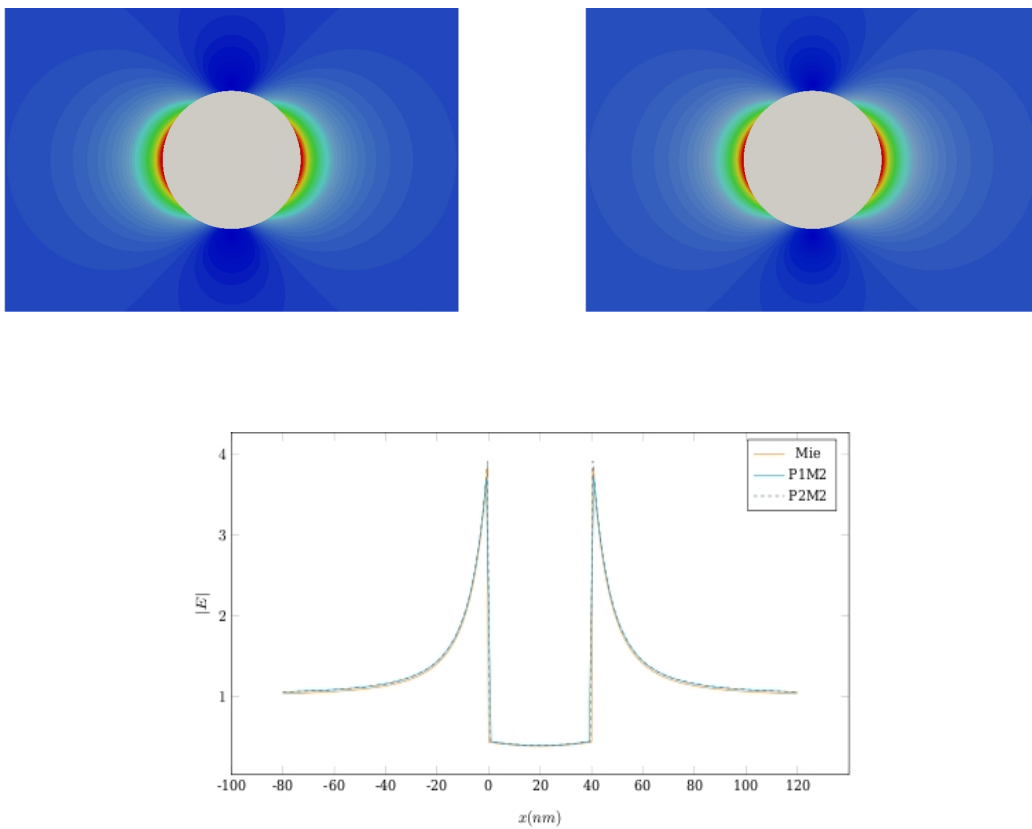

Figure 2. Scattering of a 20 nanometer radius gold nanosphere by a plane wave. The gold properties are described by a Drude dispersion model. Modulus of the electric field in the frequency-domain. Top left figure: Mie solution. Top right figure: numerical solution. Bottom figure: 1d plot of the electric field modulus for various orders of approximation (PhD thesis of Jonathan Viquerat).

4.2. Elastodynamic wave propagation

Elastic wave propagation in interaction with solids are encountered in a lot of scientific and engineering contexts. One typical example is geoseismic wave propagation, in particular in the context of earthquake dynamics or resource prospection.

4.2.1. Earthquake dynamics

To understand the basic science of earthquakes and to help engineers better prepare for such an event, scientists want to identify which regions are likely to experience the most intense shaking, particularly in populated sediment-filled basins. This understanding can be used to improve buildings in high hazard areas and to help engineers design safer structures, potentially saving lives and property. In the absence of deterministic earthquake prediction, forecasting of earthquake ground motion based on simulation of scenarios is one of the most promising tools to mitigate earthquake related hazard. This requires intense modeling that meets the spatial and temporal resolution scales of the continuously increasing density and resolution of the seismic instrumentation, which record dynamic shaking at the surface, as well as of the basin models. Another important issue is to improve the physical understanding of the earthquake rupture processes and seismic wave propagation. Large-scale simulations of earthquake rupture dynamics and wave propagation are currently the only means to investigate these multiscale physics together with data assimilation and inversion. High resolution models are also required to develop and assess fast operational analysis tools for real time seismology and early warning systems.

Numerical methods for the propagation of seismic waves have been studied for many years. Most of existing numerical software rely on finite difference type methods. Among the most popular schemes, one can cite the staggered grid finite difference scheme proposed by Virieux [55] and based on the first order velocity-stress hyperbolic system of elastic waves equations, which is an extension of the scheme derived by Yee [56] for the solution of the Maxwell equations. Many improvements of this method have been proposed, in particular, higher order schemes in space or rotated staggered-grids allowing strong fluctuations of the elastic parameters. Despite these improvements, the use of cartesian grids is a limitation for such numerical methods especially when it is necessary to incorporate surface topography or curved interface. Moreover, in presence of a non planar topography, the free surface condition needs very fine grids (about 60 points by minimal Rayleigh wavelength) to be approximated. In this context, our objective is to develop high order unstructured mesh based methods for the numerical solution of the system of elastodynamic equations for elastic media in a first step, and then to extend these methods to a more accurate treatment of the heterogeneities of the medium or to more complex propagation materials such as viscoelastic media which take into account the intrinsic attenuation. Initially, the team has considered in detail the necessary methodological developments for the large-scale simulation of earthquake dynamics [1]. More recently, the team has initiated a close collaboration with CETE Méditerranée <http://www.cete-mediterranee.fr/gb> which is a regional technical and engineering centre whose activities are concerned with seismic hazard assessment studies, and IFSTTAR <http://www.ifsttar.fr/en/welcome> which is the French institute of science and technology for transport, development and networks, conducting research studies on control over aging, risks and nuisances.

4.2.2. Seismic exploration

This application topic is considered in close collaboration with the MAGIQUE-3D project-team at Inria Bordeaux - Sud-Ouest which is coordinating the Depth Imaging Partnership (DIP) <http://dip.inria.fr> between Inria and TOTAL. The research program of DIP includes different aspects of the modeling and numerical simulation of seismic wave propagation that must be considered to construct an efficient software suites for producing accurate images of the subsurface. Our common objective with the MAGIQUE-3D project-team is to design high order unstructured mesh based methods for the numerical solution of the system of elastodynamic equations in the time-domain and in the frequency-domain, that will be used as forward modelers in appropriate inversion procedures.

5. New Software and Platforms

5.1. DIOGENeS

Discontinuous Galerkin Nanoscale Solvers

KEYWORDS: High-Performance Computing - Computational electromagnetics - Discontinuous Galerkin - Computational nanophotonics

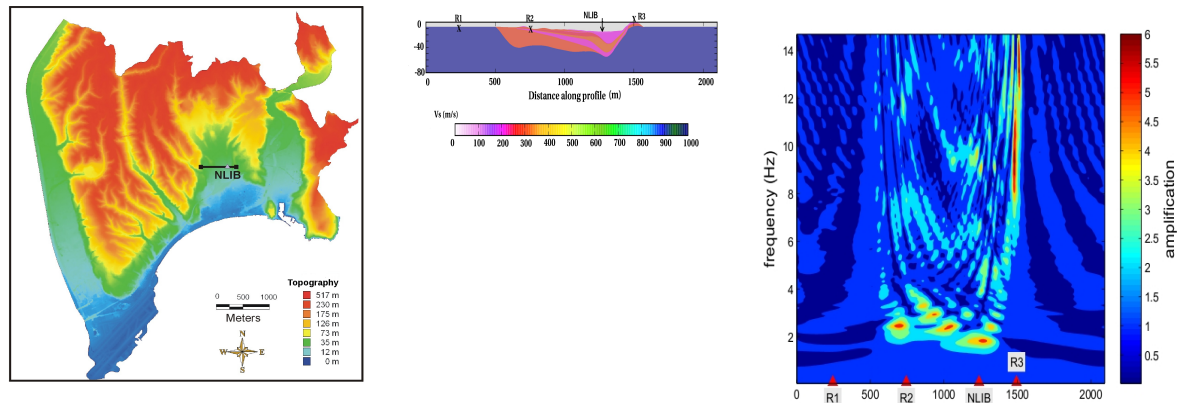

Figure 3. Propagation of a plane wave in a heterogeneous model of Nice area (provided by CETE Méditerranée).
 Left figure: topography of Nice and location of the cross-section used for numerical simulations (black line).
 Middle figure: S-wave velocity distribution along the cross-section in the Nice basin. Right figure: transfer functions (amplification) for a vertically incident plane wave ; receivers every 5 m at the surface. This numerical simulation was performed using a numerical method for the solution of the elastodynamics equations coupled to a Generalized Maxwell Body (GMB) model of viscoelasticity (PhD thesis of Fabien Peyrusse).

FUNCTIONAL DESCRIPTION: DIOGENeS relies on a two layer architecture. The core of the suite is a library of generic software components (data structures and algorithms) for the implementation of high order DG (Discontinuous Galerkin) and HDG (Hybridizable Discontinuous Galerkin) schemes formulated on unstructured tetrahedral and hybrid structured/unstructured (cubic/tetrahedral) meshes. This library is used to develop dedicated simulation software for time-domain and frequency-domain problems relevant to nanophotonics and nanoplasmonics, considering various material models.

- Contact: Stéphane Lanteri
- URL: <http://www-sop.inria.fr/nachos/index.php/Software/DIOGENeS>

5.2. GERShWIN

discontinuous GalERkin Solver for microWave INteraction with biological tissues

KEYWORDS: High-Performance Computing - Computational electromagnetics - Discontinuous Galerkin - Computational bioelectromagnetics

FUNCTIONAL DESCRIPTION: GERShWIN is based on a high order DG method formulated on unstructured tetrahedral meshes for solving the 3D system of time-domain Maxwell equations coupled to a Debye dispersion model.

- Contact: Stéphane Lanteri
- URL: <http://www-sop.inria.fr/nachos/index.php/Software/GERShWIN>

5.3. HORSE

High Order solver for Radar cross Section Evaluation

KEYWORDS: High-Performance Computing - Computational electromagnetics - Discontinuous Galerkin

FUNCTIONAL DESCRIPTION: HORSE is based on a high order HDG (Hybridizable Discontinuous Galerkin) method formulated on unstructured tetrahedral and hybrid structured/unstructured (cubic/tetrahedral) meshes for the discretization of the 3D system of frequency-domain Maxwell equations, coupled to domain decomposition solvers.

- Contact: Stéphane Lanteri
- URL: <http://www-sop.inria.fr/nachos/index.php/Software/HORSE>

6. New Results

6.1. Electromagnetic wave propagation

6.1.1. Numerical treatment of non-local dispersion for nanoplasmonics

Participants: Stéphane Lanteri, Claire Scheid, Nikolai Schmitt, Jonathan Viquerat.

When metallic nanostructures have sub-wavelength sizes and the illuminating frequencies are in the regime of metal's plasma frequency, electron interaction with the exciting fields have to be taken into account. Due to these interactions, plasmonic surface waves can be excited and cause extreme local field enhancements (surface plasmon polariton electromagnetic waves). Exploiting such field enhancements in applications of interest requires a detailed knowledge about the occurring fields which can generally not be obtained analytically. For the numerical modeling of light/matter interaction on the nanoscale, the choice of an appropriate model is a crucial point. Approaches that are adopted in a first instance are based on local (no interaction between electrons) dispersion models e.g. Drude or Drude-Lorentz. From the mathematical point of view, these models lead to an additional ordinary differential equation in time that is coupled to Maxwell's equations. When it comes to very small structures in a regime of 2 nm to 25 nm, non-local effects due to electron collisions have to be taken into account. Non-locality leads to additional, in general non-linear, partial differential equations and is significantly more difficult to treat, though. In this work, we study a DGT method able to solve the system of Maxwell equations coupled to a linearized non-local dispersion model relevant to nanoplasmonics. This year, we have developed a parallel DGT solver for the three-dimensional Maxwell equations coupled to a non-local Drude model. Both centered flux-based and upwind flux-based DG schemes have been considered, in combination with with leap-frog and Runge-Kutta time stepping respectively. This is the object of the submitted paper [41]. At the same time, we pursue a study in collaboration with Serge Nicaise (Université de Valenciennes et du Hainaut-Cambresis) on the stability properties of this model both at the continuous and the discrete level.

6.1.2. Numerical modeling of metasurfaces

Participants: Loula Fezoui, Stéphane Lanteri, Liang Li [UESTC, Chengdu, China], Ronan Perrussel [Laplace laboratory, Toulouse].

Metamaterials are composed of periodic subwavelength metal/dielectric structures that resonantly couple to the electric and/or magnetic components of the incident electromagnetic fields, exhibiting properties that are not found in nature. Planar metamaterials with subwavelength thickness, or metasurfaces, consisting of a layer of dielectric or plasmonic nanostructures, can be readily fabricated using lithography and nanoprinting methods, and the ultrathin thickness in the wave propagation direction can greatly suppress the undesirable losses. Metasurfaces enable a spatially varying optical response, mold optical wavefronts into shapes that can be designed at will, and facilitate the integration of functional materials to accomplish active control and greatly enhanced nonlinear response. Designing metasurfaces is generally a challenging inverse problem. A recently introduced synthesis techniques is based on so-called General Sheet Transition Conditions (GSTC) that can be leveraged to define the components of general bianisotropic surface susceptibility tensors characterizing the metasurface. A GSTC-based design technique has several advantages: 1) it is exact; 2) it is general, transforming arbitrary incident waves into arbitrary reflected and transmitted waves, 3) it often admits closed-form solutions, 4) it provides deep insight into the physics of the transformations, 5) it allows multiple (at least up to 4) simultaneous and independent transformations. We study the numerical treatment of GSTC in the time-domain and frequency-domain regimes in the DG and HDG settings respectively.

6.1.3. Corner effects in nanoplasmonics

Participants: Camille Carvalho [Applied Mathematics Department, University of California Merced, USA], Patrick Ciarlet [ENSTA, POEMS project-team], Claire Scheid.

In this work, we study nanoplasmonic structures with corners (typically a diedral/triangular structure). This is the central subject considered in the PhD thesis of Camille Carvalho. In the latter, the focus is made on a lossless Drude dispersion model with a frequency-domain approach. Several well posedness problems arise due to the presence of corners and are addressed in the PhD thesis. A time-domain approach in this context is also relevant and we propose to use the techniques developed in the team in this prospect. Even if both approaches (time-domain and frequency-domain) represent similar physical phenomena, problems that arise are different. These two approaches appear as complementary; it is thus worth bridging the gap between the two frameworks. We are currently performing a thorough comparison in the case of these 2D structures with corners and we especially focus on the amplitude principle limit that raises a lot of questions.

6.1.4. Travelling waves for the non-linear Schrödinger equation in 2D

Participants: David Chiron [J.A. Dieudonné Laboratory, Université Nice Sophia Antipolis], Claire Scheid.

We are interested in the numerical study of the two-dimensional travelling waves of the non-linear Schrödinger equation for a general non-linearity and with nonzero condition at infinity. This equation is appearing in models of nonlinear optics. It has a variational structure that we propose to exploit to design a numerical method. We continue the study initiated in [1] and investigate excited states of the Kadomtsev-Petviashvili-I (KP-I) and Gross-Pitaevskii (GP) equations in dimension 2. We address numerically the question of the Morse index of some explicit solutions of KP-I that form a parametrized family of solutions. The results confirm that the lump solitary wave has Morse index one and that the other explicit solutions correspond to excited states. We then turn to the 2D GP equation which in some long wave regime converges to the KP-I equation. We finally perform numerical simulations showing that the other explicit solitary waves solutions to the KP-I equation give rise to new branches of travelling waves of GP corresponding to excited states. This is the object of the submitted paper [37] (currently under a minor revision process).

6.1.5. A structure preserving numerical discretization framework for the Maxwell Klein Gordon equation in 2D.

Participants: Snorre Christiansen [Department of Mathematics, University of Oslo, Norway], Claire Scheid.

Toward a better understanding of non-linear optical phenomena, we focus on the case of the Maxwell Klein Gordon (MKG) equation in dimension 2. This equation appears in the context of quantum electrodynamics but also in relativity. We propose to develop a numerical discretization framework that takes advantage of the Hamiltonian structure of the equation. The gauge invariance is recovered at the discrete level with the help of the Lattice Gauge theory. We then propose a fully discrete scheme and prove its convergence. The strategy of proof, based on discrete energy principle, is developed in a more general context and next applied in the particular case of MKG equation. This work has been conducted and finalized during a five month's stay of C. Scheid at the University of Oslo through an invitation in the context of the ERC Starting Grant project STUCCOFIELD of S. Christiansen. This work has been presented in 2017 in one conference (see [32]) and at the occasion of an invitation for a seminar (see section Invited talks).

6.1.6. Multiscale DG methods for the time-domain Maxwell equations

Participants: Alexis Gobé, Stéphane Lanteri, Raphaël Léger, Diego Paredes Concha [Instituto de Matemáticas, Universidad Católica de Valparaíso, Chile], Claire Scheid, Frédéric Valentin [LNCC, Petropolis, Brazil].

Although the DGTD method has already been successfully applied to complex electromagnetic wave propagation problems, its accuracy may seriously deteriorate on coarse meshes when the solution presents multiscale or high contrast features. In other physical contexts, such an issue has led to the concept of multiscale basis functions as a way to overcome such a drawback and allow numerical methods to be accurate on coarse meshes. The present work, which is conducted in the context of the HOMAR Associate Team, is concerned

with the study of a particular family of multiscale methods, named Multiscale Hybrid-Mixed (MHM) methods. Initially proposed for fluid flow problems, MHM methods are a consequence of a hybridization procedure which characterizes the unknowns as a direct sum of a coarse (global) solution and the solutions to (local) problems with Neumann boundary conditions driven by the purposely introduced hybrid (dual) variable. As a result, the MHM method becomes a strategy that naturally incorporates multiple scales while providing solutions with high order accuracy for the primal and dual variables. The completely independent local problems are embedded in the upscaling procedure, and computational approximations may be naturally obtained in a parallel computing environment. In this study, a family of MHM methods is proposed for the solution of the time-domain Maxwell equations where the local problems are discretized either with a continuous FE method or a DG method (that can be viewed as a multiscale DGTD method). Preliminary results have been obtained in the two-dimensional case. The corresponding paper submitted at the end of 2016 is currently under revision (preprint available on HAL [14]). This work has also been presented in a conference in 2017, see [33]

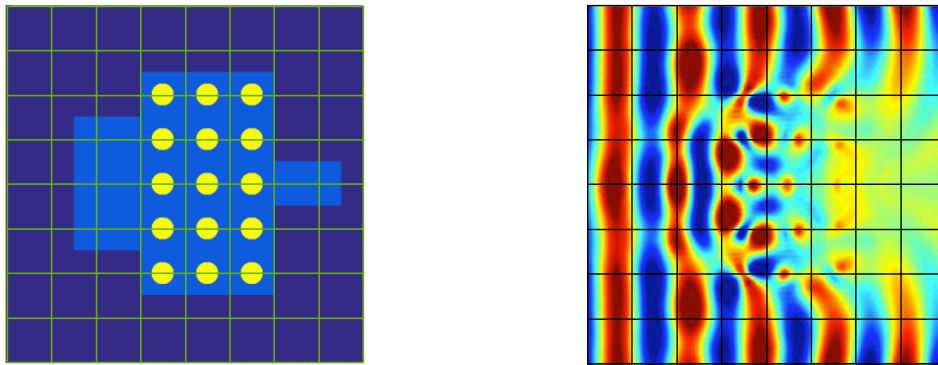

Figure 4. Light propagation in a photonic crystal structure using a MHM-DGTD method for solving the 2D Maxwell's equations. Left: quadrangular mesh. Right: contour lines of the amplitude of the electric field.

6.1.7. HDG methods for the time-domain Maxwell equations

Participants: Alexandra Christophe-Argenvillier [MIT, USA], Stéphane Descombes, Stéphane Lanteri, Georges Nehmetallah.

This study is concerned with the development of accurate and efficient solution strategies for the system of 3D time-domain Maxwell equations coupled to local dispersion models (e.g. Debye, Drude or Drude-Lorentz models) in the presence of locally refined meshes. Such meshes impose a constraint on the allowable time step for explicit time integration schemes that can be very restrictive for the simulation of 3D problems. We consider here the possibility of using an unconditionally stable implicit time or a locally implicit time integration scheme combined to a HDG discretization method. As a preliminary step, we have investigated a fully explicit HDG method generalizing the classical upwind flux-based DG method for the system of time-domain Maxwell equations. We have studied the stability of this new HDG method and in particular, the influence of the stabilization parameter on the CFL condition. We are now assessing the conditions under which we can obtain a superconverging HDG method.

6.1.8. HDG methods for the frequency-domain Maxwell equations

Participants: Stéphane Lanteri, Ludovic Moya.

In the context of the ANR TECSER project, we continue our efforts towards the development of scalable high order HDG methods for the solution of the system of 3D frequency-domain Maxwell equations. We aim at fully exploiting the flexibility of the HDG discretization framework with regards to the adaptation of the interpolation order (p -adaptivity) and the mesh (h -adaptivity). In particular, we study the formulation of HDG methods on a locally refined non-conforming tetrahedral mesh and on a non-conforming hybrid cubic/tetrahedral mesh. We also investigate the coupling between the HDG formulation and a BEM (Boundary Element Method) discretization of an integral representation of the electromagnetic field in the case of propagation problems theoretically defined in unbounded domains. The associated methodological contributions are implemented in the HORSE simulation software.

6.1.9. HDG methods for frequency-domain plasmonics

Participants: Stéphane Lanteri, Mostafa Javadzadeh Moghtader, Liang Li [UESTC, Chengdu, China], Asger Mortensen [DTU Fotonik, Technical University of Denmark], Martijn Wubs [DTU Fotonik, Technical University of Denmark].

In this collaboration with physicists at DTU Fotonik, we study HDG methods for solving the frequency-domain Maxwell's equations coupled to the Nonlocal Hydrodynamic Drude (NHD) and Generalized Nonlocal Optical Response (GNOR) models, which are employed to describe the optical properties of nanoplasmonic scatterers and waveguides. The formulations of the HDG method for these two models are extension of our previous works for classical microwave applications. In the present case, two conservativity conditions are globally enforced to make the problem solvable and to guarantee the continuity of the tangential component of the electric field and the normal component of the current density. Numerical results show that the proposed HDG methods converge at optimal rate. These new HDG formulations have been implemented and numerically assessed for two-dimensional problems. Beside, we are also considering the three-dimensional case

6.1.10. Exponential time integrators for a DGT method

Participants: Stéphane Descombes, Stéphane Lanteri, Bin Li [UESTC, Chengdu, China], Hao Wang [UESTC, Chengdu, China], Li Xu [UESTC, Chengdu, China].

The objective of this study is to design efficient and (high order) accurate time integration strategies for the system of time-domain Maxwell equations discretized in space by a high order discontinuous Galerkin scheme formulated on locally refined unstructured meshes. A new family of implicit-explicit (IMEX) schemes using exponential time integration is developed. The Lawson procedure is applied based on a partitioning of the underlying tetrahedral mesh in coarse and fine parts, allowing the construction of a time advancing strategy that combines an exact integration of the semi-discrete system for the problem unknowns associated to the elements of the fine part, with an arbitrary high order explicit time integration scheme for the Lawson-transformed system.

6.2. Elastodynamic wave propagation

6.2.1. HDG method for the frequency-domain elastodynamic equations

Participants: H el ene Barucq [MAGIQUE-3D project-team, Inria Bordeaux - Sud-Ouest], Marie Bonnasse, Julien Diaz [MAGIQUE-3D project-team, Inria Bordeaux - Sud-Ouest], St ephane Lanteri.

One of the most used seismic imaging methods is the full waveform inversion (FWI) method which is an iterative procedure whose algorithm is the following. Starting from an initial velocity model, (1) compute the solution of the wave equation for the N sources of the seismic acquisition campaign, (2) evaluate, for each source, a residual defined as the difference between the wavefields recorded at receivers on the top of the subsurface during the acquisition campaign and the numerical wavefields, (3) compute the solution of the wave equation using the residuals as sources, and (4) update the velocity model by cross correlation of images produced at steps (1) and (3). Steps (1)-(4) are repeated until convergence of the velocity model is achieved. We then have to solve $2N$ wave equations at each iteration. The number of sources, N , is usually large (about

1000) and the efficiency of the inverse solver is thus directly related to the efficiency of the numerical method used to solve the wave equation. Seismic imaging can be performed in the time-domain or in the frequency-domain regime. In this work which is conducted in the framework of the Depth Imaging Partnership (DIP) between Inria and TOTAL, we adopt the second setting. The main difficulty with frequency-domain inversion lies in the solution of large sparse linear systems which is a challenging task for realistic 3D elastic media, even with the progress of high performance computing. In this context, we study novel high order HDG methods formulated on unstructured meshes for the solution of the frequency-domain elastodynamic equations. Instead of solving a linear system involving the degrees of freedom of all volumic cells of the mesh, the principle of a HDG formulation is to introduce a new unknown in the form of Lagrange multiplier representing the trace of the numerical solution on each face of the mesh. As a result, a HDG formulation yields a global linear system in terms of the new (surfacic) unknown while the volumic solution is recovered thanks to a local computation on each element.

6.2.2. *Multiscale DG methods for the time-domain elastodynamic equations*

Participants: Marie-Hélène Lallemand, Raphaël Léger, Wesley Da Silva Pereira [LNCC, Petropolis, Brazil], Frédéric Valentin [LNCC, Petropolis, Brazil].

In the context of the visit of Frédéric Valentin in the team, we have initiated a study aiming at the design of novel multiscale methods for the solution of the time-domain elastodynamic equations, in the spirit of MHM (Multiscale Hybrid-Mixed) methods previously proposed for fluid flow problems. Motivation in that direction naturally came when dealing with non homogeneous anisotropic elastic media as those encountered in geodynamics related applications, since multiple scales are naturally present when high contrast elasticity parameters define the propagation medium. Instead of solving the usual system expressed in terms of displacement or displacement velocity, and stress tensor variables, a hybrid mixed-form is derived in which an additional variable, the Lagrange multiplier, is sought as representing the (opposite) of the surface tension defined at each face of the elements of a given discretization mesh. We consider the velocity/stress formulation of the elastodynamic equations, and study a MHM method defined for a heterogeneous medium where each elastic material is considered as isotropic to begin with. If the source term (the applied given force on the medium) is time independent, and if we are given an arbitrarily coarse conforming mesh (triangulation in 2D, tetrahedrization in 3D), the proposed MHM method consists in first solving a series of fully decoupled (therefore parallelizable) local (element-wise) problems defining parts of the full solution variables which are directly related to the source term, followed by the solution of a global (coarse) problem, which yields the degrees of freedom of both the Lagrange multiplier dependent part of the full solution variables and the Lagrange multiplier itself. Finally, the updating of the full solution variables is obtained by adding each splitted solution variables, before going on the next time step of a leap-frog time integration scheme. Theoretical analysis and implementation of this MHM method where the local problems are discretized with a DG method, are underway.

6.3. High performance numerical computing

6.3.1. *Porting a DGTD solver for bioelectromagnetics to the DEEP-ER architecture*

Participants: Alejandro Duran [Barcelona Supercomputing Center, Spain], Stéphane Lanteri, Raphaël Léger, Damian A. Mallón [Juelich Supercomputing Center, Germany].

We are concerned here with the porting of the GERSHWIN DGTD solver for computational bioelectromagnetics to the novel heterogeneous architecture proposed in the DEEP-ER european project on exascale computing. This architecture is based on a Cluster/Booster division concept (see Fig. 5). The Booster nodes are based on the Intel Many Integrated Core (MIC) architecture. Therefore, one objective of our efforts is the algorithmic adaptation of the DG kernels in order to leverage the vectorizing capabilities of the MIC processor. The other activities that are undertaken in the context of our contribution to this project aim at exploiting the software environments and tools proposed by DEEP-ER partners for implementing resiliency strategies and high performance I/O operations. In particular, the Cluster nodes are used for running some parts of the pre- and post-processing phases of the DGTD solver which do not lend themselves well to multithreading, as well as

I/O intensive routines. One possibility to achieve this is to consider a model in which these less scalable and I/O phases are reverse-offloaded from Booster processes to Cluster processes in a one-to-one mapping. This is achieved by exploiting the OmpSs offload functionality, developed at Barcelona Supercomputing Center for the DEEP-ER platform.

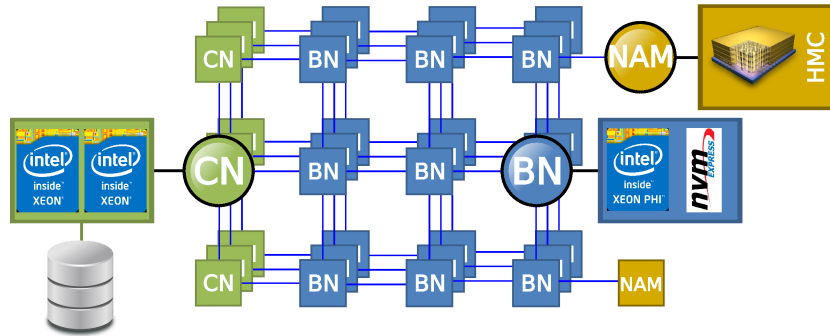

Figure 5. DEEP-ER hardware architecture sketch.

6.3.2. High order HDG schemes and domain decomposition solvers for frequency-domain electromagnetics

Participants: Emmanuel Agullo [HIEPACS project-team, Inria Bordeaux - Sud-Ouest], Luc Giraud [HIEPACS project-team, Inria Bordeaux - Sud-Ouest], Matthieu Kuhn [HIEPACS project-team, Inria Bordeaux - Sud-Ouest], Stéphane Lanteri, Ludovic Moya, Olivier Rouchon [CINES, Montpellier].

This work is undertaken in the context of the ANR TECSER project on one hand, and PRACE 4IP project on the other hand, and is concerned with the development of scalable frequency-domain electromagnetic wave propagation solvers, in the framework of the HORSE simulation software. HORSE is based on a high order HDG scheme formulated on an unstructured tetrahedral grid for the discretization of the system of three-dimensional Maxwell equations in heterogeneous media, leading to the formulation of large sparse indefinite linear system for the hybrid variable unknowns. This system is solved with domain decomposition strategies that can be either a purely algebraic algorithm working at the matrix operator level (i.e. a black-box solver), or a tailored algorithm designed at the continuous PDE level (i.e. a PDE-based solver). In the former case, we use the MaPhyS (Massively Parallel Hybrid Solver) developed in the HIEPACS project-team at Inria Bordeaux - Sud-Ouest.

6.4. Applications

6.4.1. Light transmission in subwavelength gratings

Participants: Leandro Andrade Couto Fonseca, Hugo Enrique Hernandez Figueroa [Universidade Estadual de Campinas, Sao Paulo, Brazil], Laurent Labonté [Information Quantique avec la Lumière et la Matière (QILM) team, INPHYNI, Université Nice Sophia Antipolis], Stéphane Lanteri, Jonathan Viquerat.

Silicon photonics has great potential to bringing together two technological areas that have transformed the last century, electronics and photonics. Silicon waveguides are important components for tailoring photonic functions on silicon. They have been studied extensively over the past two decades. There are a number of waveguide geometries that have been developed in silicon. The most common are strip waveguides, rib waveguides and slot waveguides. The Bragg grating is a fundamental component in various optical devices and has applications in areas as diverse communications, laser and sensors. In the simplest configuration,

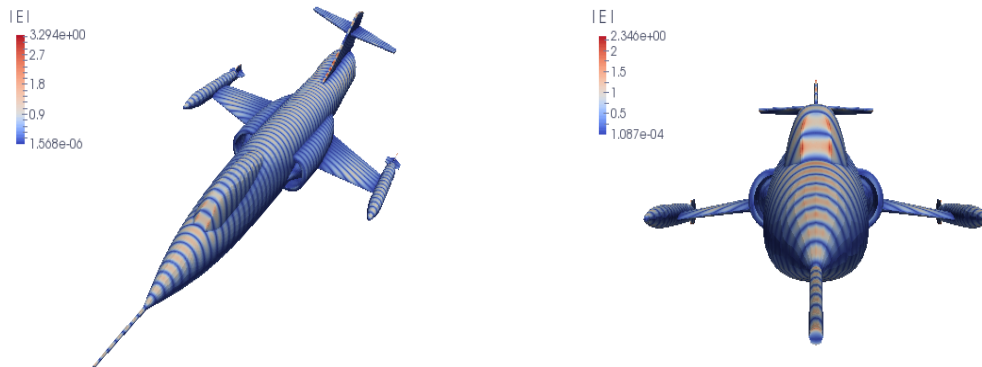

Figure 6. Scattering of a plane wave by a Lockheed F-104 Starfighter. Contour lines of the amplitude of the electric field. Simulations are performed with a HDG scheme based on a cubic interpolation of the electric and magnetic field unknowns, combined with a PDE-based domain decomposition solver.

a Bragg grating is a structure with periodic modulation of the effective refractive index. This modulation is commonly achieved by varying the refractive index (e.g. alternating material) or the physical dimensions of the waveguide. At each boundary, a reflection of the travelling light occurs, and the relative phase of the reflected signal is determined by the grating period and the wavelength. The repeated modulation of the refractive index results in multiple and distributed reflections. The reflected signals only interfere constructively in a narrow band around one particular wavelength, namely the Bragg wavelength. Within this range, light is strongly reflected. At other wavelengths, the multiple reflections interfere destructively and cancel each other out, and as a result, light is transmitted through the grating. This is the functional principle of the concept SubWavelength Gratings (SWG). In the context of the OPENING (On-chiP wirEless quantum state eNginEerING) project of the UCA JEDI Excellence Initiative, we collaborate with the QILM team of the INPHYNI laboratory, on the numerical modeling of light propagation in SWG waveguides, using a high order DGTD solver from the DIOGENeS software suite. Two situations are considered: (1) in a first step, an ideal configuration corresponding to a virtual design will be simulated; (2) in a second step, several deformed configurations, which are more in line with actual designs (i.e. from lithography), are studied with the goal of identifying the main sources of performance degradation from the transmission point of view.

6.4.2. Light diffusion in nanostructured optical fibers

Participants: Wilfried Blanc [Optical Fibers team, INPHYNI, Université Nice Sophia Antipolis], Stéphane Lanteri, Claire Scheid.

Optical fibers are the basis for applications that have grown considerably in recent years (telecommunications, sensors, fiber lasers, etc.). Despite these undeniable successes, it is necessary to develop new generations of amplifying optical fibers that will overcome some limitations typical of silica. In this sense, the amplifying Transparent Glass Ceramics (TGC), and particularly the fibers based on this technology, open new perspectives that combine the mechanical and chemical properties of a glass host and the augmented spectroscopic properties of embedded nanoparticles, particularly rare earth-doped oxide nanoparticles. Such rare earth-doped silica-based optical fibers with transparent glass ceramic (TGC) core are fabricated by the Optical Fibers team of the Laboratory of Condensed Matter Physics (INPHYNI) in Nice. The objective of this collaboration with Wilfried Blanc at LPMC is the study of optical transmission terms of loss due to scattering through the numerical simulation of light propagation in a nanostructured optical fiber core using a high order DGTD method developed in the team.

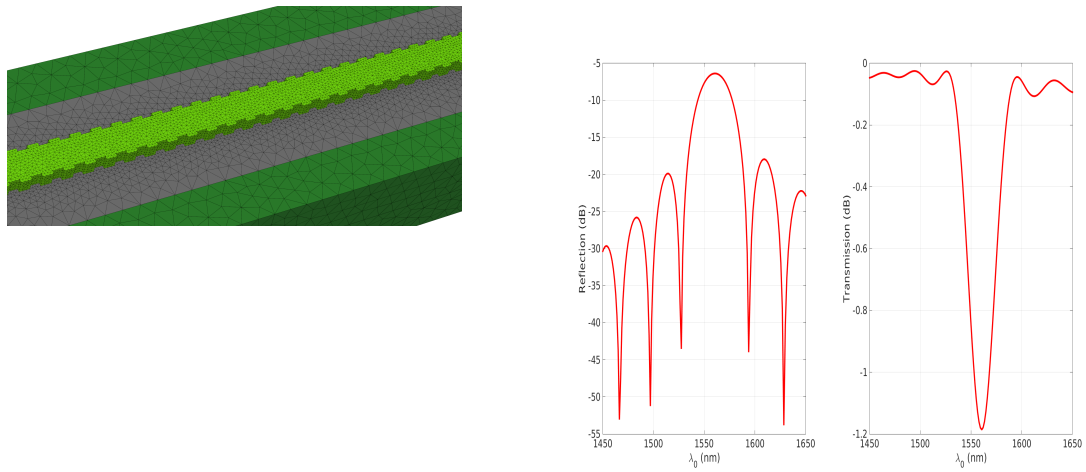

Figure 7. Partial view of a SWG waveguide tetrahedral mesh (top left); reflection and transmission coefficients (bottom).1

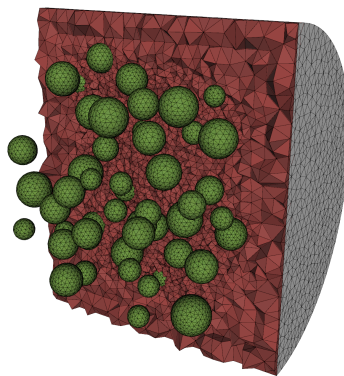

Figure 8. Unstructured tetrahedral mesh of a nanostructured optical fiber core.

6.4.3. Gap-plasmon confinement with gold nanocubes

Participants: Stéphane Lanteri, Antoine Moreau [Institut Pascal, Université Blaise Pascal], Arnel Pitelet [Institut Pascal, Université Blaise Pascal], Claire Scheid, Nikolai Schmitt, Jonathan Viquerat.

The propagation of light in a slit between metals is known to give rise to guided modes. When the slit is of nanometric size, plasmonic effects must be taken into account, since most of the mode propagates inside the metal. Indeed, light experiences an important slowing-down in the slit, the resulting mode being called *gap-plasmon*. Hence, a metallic structure presenting a nanometric slit can act as a light trap, i.e. light will accumulate in a reduced space and lead to very intense, localized fields. Recently, the chemical production of random arrangements of nanocubes on gold films at low cost was proved possible by Antoine Moreau and colleagues at Institut Pascal. Nanocubes are separated from the gold substrate by a dielectric spacer of variable thickness, thus forming a narrow slit under the cube. When excited from above, this configuration is able to support gap-plasmon modes which, once trapped, will keep bouncing back and forth inside the cavity. At visible frequencies, the lossy behavior of metals will cause the progressive absorption of the trapped electromagnetic field, turning the metallic nanocubes into efficient absorbers. The frequencies at which this absorption occurs can be tuned by adjusting the dimensions of the nanocube and the spacer. In collaboration with Antoine Moreau, we propose to study numerically the impact of the geometric parameters of the problem on the behaviour of a single nanocube placed over a metallic slab (see Fig. 9). The behavior of single nanocubes on metallic plates has been simulated, for lateral sizes c ranging from 50 to 80 nm, and spacer thicknesses δ from 3 to 22 nm. The absorption efficiency in the cube Q_{cube} at the resonance frequency is retrieved from the results of each computation (see Fig. 10).

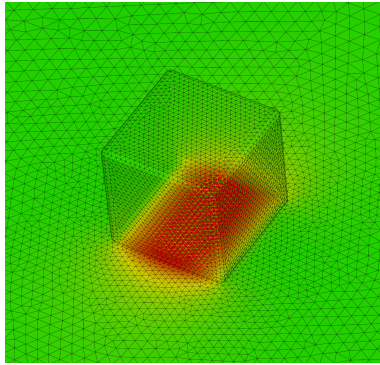

Figure 9. Meshes of rounded nanocubes with rounding radii ranging from 2 to 10 nm. Red cells correspond to the cube. The latter lies on the dielectric spacer (gray cells) and the metallic plate (green). Blue cells represent the air surrounding the device.

6.4.4. Light-trapping in nanostructured solar cells

Participants: Urs Aeberhard [IEK5 - Photovoltaik, Forschungszentrum Juelich GmbH, German], Karsten Bittkau [IEK5 - Photovoltaik, Forschungszentrum Juelich GmbH, German], Alexis Gobé, Stéphane Lanteri.

This work is undertaken in the context of the EoCoE Center of Excellence in collaboration with researchers from IEK5 - Photovoltaik, Forschungszentrum Juelich GmbH, Germany. The objective is to design a scalable high order DGTD solver for the simulation of light trapping in a multi-layer solar cell with surface texture. For that purpose, we rely on the DIOGENeS software suite from which we extract a high order DGTD solver for the problem under consideration, taking into account its specificities (in particular, with regards to material models and boundary conditions). We also need to specify and develop a dedicated preprocessing tool for building topography conforming geometrical models. Simulations are performed on the Occigen PRACE system at CINES.



$$c = 70 \text{ nm}, \delta = 12 \text{ nm}$$

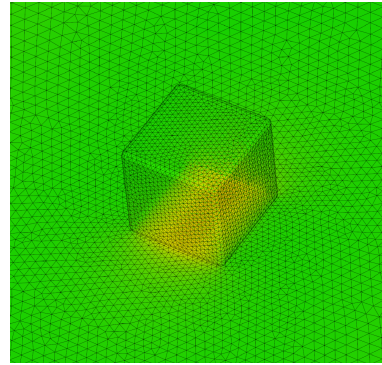

$$c = 60 \text{ nm}, \delta = 18 \text{ nm}$$

Figure 10. Amplitude of the discrete Fourier transform of the magnetic field for different nanocube configurations. All field maps are scaled identically for better comparison. The obtained field is more intense for configurations that yield high Q_{cube} values.

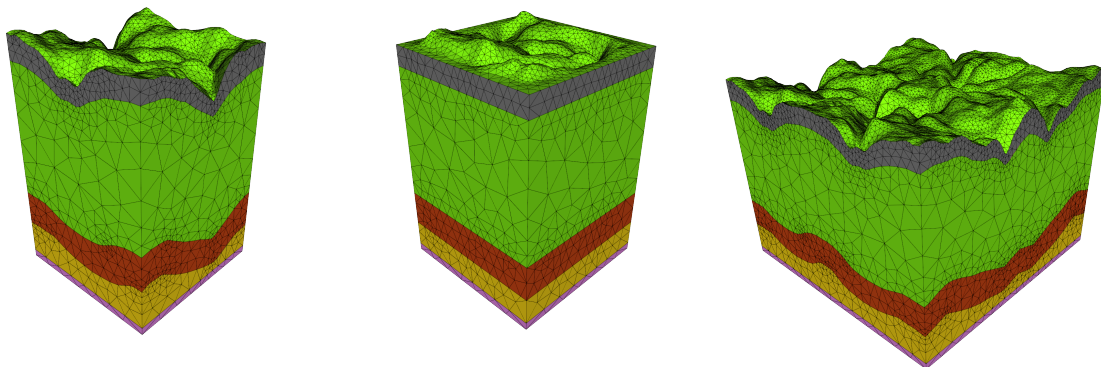

Figure 11. Simulation of light trapping in a multi-layer solar cell with surface texture using a high order DGTD fullwave solver and topography conforming geometrical models.

7. Partnerships and Cooperations

7.1. National Initiatives

7.1.1. Inria Project Lab

7.1.1.1. C2S@Exa (Computer and Computational Sciences at Exascale)

Participants: Olivier Aumage [STORM project-team, Inria Bordeaux - Sud-Ouest], Philippe Helluy [TONUS project-team, Inria Nancy - Grand-Est], Luc Giraud [HIEPACS project-team, Inria Bordeaux - Sud-Ouest], Stéphane Lanteri [Coordinator of the project], Jean-François Méhaut [CORSE project-team, Inria Grenoble - Rhône-Alpes], Christian Perez [AVALON project-team, Inria Grenoble - Rhône-Alpes].

Since January 2013, the team is coordinating the C2S@Exa http://www-sop.inria.fr/c2s_at_exa Inria Project Lab (IPL). This national initiative aims at the development of numerical modeling methodologies that fully exploit the processing capabilities of modern massively parallel architectures in the context of a number of selected applications related to important scientific and technological challenges for the quality and the security of life in our society. At the current state of the art in technologies and methodologies, a multidisciplinary approach is required to overcome the challenges raised by the development of highly scalable numerical simulation software that can exploit computing platforms offering several hundreds of thousands of cores. Hence, the main objective of C2S@Exa is the establishment of a continuum of expertise in the computer science and numerical mathematics domains, by gathering researchers from Inria project-teams whose research and development activities are tightly linked to high performance computing issues in these domains. More precisely, this collaborative effort involves computer scientists that are experts of programming models, environments and tools for harnessing massively parallel systems, algorithmists that propose algorithms and contribute to generic libraries and core solvers in order to take benefit from all the parallelism levels with the main goal of optimal scaling on very large numbers of computing entities and, numerical mathematicians that are studying numerical schemes and scalable solvers for systems of partial differential equations in view of the simulation of very large-scale problems.

7.1.2. ANR project

7.1.2.1. TECSER

Participants: Emmanuel Agullo [HIEPACS project-team, Inria Bordeaux - Sud-Ouest], Xavier Antoine [CORIDA project-team, Inria Nancy - Grand-Est], Patrick Breuil [Nuclétudes, Les Ulis], Thomas Frachon, Luc Giraud [HIEPACS project-team, Inria Bordeaux - Sud-Ouest], Stéphane Lanteri, Ludovic Moya, Guillaume Sylvand [Airbus Group Innovations].

Type: ANR ASTRID

Duration: May 2014 - April 2017

Coordinator: Inria

Partner: Airbus Group Innovations, Inria, Nuclétudes

Inria contact: Stéphane Lanteri

Abstract: the objective of the TECSER project is to develop an innovative high performance numerical methodology for frequency-domain electromagnetics with applications to RCS (Radar Cross Section) calculation of complicated structures. This numerical methodology combines a high order hybridized DG method for the discretization of the frequency-domain Maxwell in heterogeneous media with a BEM (Boundary Element Method) discretization of an integral representation of Maxwell's equations in order to obtain the most accurate treatment of boundary truncation in the case of theoretically unbounded propagation domain. Beside, scalable hybrid iterative/direct domain decomposition based algorithms are used for the solution of the resulting algebraic system of equations.

7.2. European Initiatives

7.2.1. FP7 & H2020 Projects

7.2.1.1. DEEP-ER

Title: Dynamic Exascale Entry Platform - Extended Reach

Program: FP7

Duration: October 2013 - September 2016

Coordinator: Forschungszentrum Juelich GmbH (Germany)

Partner: Intel GmbH (Germany), Bayerische Akademie der Wissenschaften (Germany), Ruprecht-Karls-Universität Heidelberg (Germany), Universität Regensburg (Germany), Fraunhofer-Gesellschaft zur Förderung der Angewandten Forschung E.V (Germany), Eurotech Spa (Italy), Consorzio Interuniversitario Cineca (Italy), Barcelona Supercomputing Center - Centro Nacional de Supercomputación (Spain), Xyratex Technology Limited (United Kingdom), Katholieke Universiteit Leuven (Belgium), Stichting Astronomisch Onderzoek in Nederland (The Netherlands) and Inria (France).

Inria contact: Stéphane Lanteri

Abstract: the DEEP-ER project aims at extending the Cluster-Booster Architecture that has been developed within the DEEP project with a highly scalable, efficient, easy-to-use parallel I/O system and resiliency mechanisms. A Prototype will be constructed leveraging advances in hardware components and integrate new storage technologies. They will be the basis to develop a highly scalable, efficient and user-friendly parallel I/O system tailored to HPC applications. Building on this I/O functionality a unified user-level checkpointing system with reduced overhead will be developed, exploiting multiple levels of storage. The DEEP programming model will be extended to introduce easy-to-use annotations to control checkpointing, and to combine automatic re-execution of failed tasks and recovery of long-running tasks from multi-level checkpoint. The requirements of HPC codes with regards to I/O and resiliency will guide the design of the DEEP-ER hardware and software components. Seven applications will be optimised for the DEEP-ER Prototype to demonstrate and validate the benefits of the DEEP-ER extensions to the Cluster-Booster Architecture.

7.2.1.2. EoCoE

Title: Energy oriented Centre of Excellence for computer applications

Programm: H2020

Duration: October 2015 - October 2018

Coordinator: CEA

Partners:

Barcelona Supercomputing Center - Centro Nacional de Supercomputación (Spain)

Commissariat A L Energie Atomique et Aux Energies Alternatives (France)

Centre Europeen de Recherche et de Formation Avancee en Calcul Scientifique (France)

Consiglio Nazionale Delle Ricerche (Italy)

The Cyprus Institute (Cyprus)

Agenzia Nazionale Per le Nuove Tecnologie, l'energia E Lo Sviluppo Economico Sostenibile (Italy)

Fraunhofer Gesellschaft Zur Forderung Der Angewandten Forschung Ev (Germany)

Instytut Chemii Bioorganicznej Polskiej Akademii Nauk (Poland)

Forschungszentrum Julich (Germany)

Max Planck Gesellschaft Zur Foerderung Der Wissenschaften E.V. (Germany)

University of Bath (United Kingdom)

Universite Libre de Bruxelles (Belgium)

Universita Degli Studi di Trento (Italy)

Inria contact: Michel Kern

The aim of the present proposal is to establish an Energy Oriented Centre of Excellence for computing applications, (EoCoE). EoCoE (pronounce “Echo”) will use the prodigious potential offered by the ever-growing computing infrastructure to foster and accelerate the European transition to a reliable and low carbon energy supply. To achieve this goal, we believe that the present revolution in hardware technology calls for a similar paradigm change in the way application codes are designed. EoCoE will assist the energy transition via targeted support to four renewable energy pillars: Meteo, Materials, Water and Fusion, each with a heavy reliance on numerical modelling. These four pillars will be anchored within a strong transversal multidisciplinary basis providing high-end expertise in applied mathematics and HPC. EoCoE is structured around a central Franco-German hub coordinating a pan-European network, gathering a total of 8 countries and 23 teams. Its partners are strongly engaged in both the HPC and energy fields; a prerequisite for the long-term sustainability of EoCoE and also ensuring that it is deeply integrated in the overall European strategy for HPC. The primary goal of EoCoE is to create a new, long lasting and sustainable community around computational energy science. At the same time, EoCoE is committed to deliver high-impact results within the first three years. It will resolve current bottlenecks in application codes, leading to new modelling capabilities and scientific advances among the four user communities; it will develop cutting-edge mathematical and numerical methods, and tools to foster the usage of Exascale computing. Dedicated services for laboratories and industries will be established to leverage this expertise and to foster an ecosystem around HPC for energy. EoCoE will give birth to new collaborations and working methods and will encourage widely spread best practices.

7.2.1.3. HPC4E

Title: HPC for Energy

Programm: H2020

Duration: December 2015 - November 2017

Coordinator: Barcelona Supercomputing Center

Partner: Barcelona Supercomputing Center (Spain), Centro de Investigaciones Energeticas, Medioambientales y Tecnologicas - CIEMAT (Spain), REPSOL SA (Spain), Iberdrola Renovables Energia SA (Spain), Lancaster University (United Kingdom), COPPE/UFRJ - Universidade Federal do Rio de Janeiro (Brazil), LNCC (Brazil), INF/UFRGS - Universidade Federal do Rio Grande do Sul (Brazil), CER/UFPE - Universidade Federal de Pernambuco (Brazil), PETROBRAS (Brazil), TOTAL SA (France), and Inria (France).

Inria contact: Stéphane Lanteri

Abstract: This project aims to apply the new exascale HPC techniques to energy industry simulations, customizing them, and going beyond the state-of-the-art in the required HPC exascale simulations for different energy sources: wind energy production and design, efficient combustion systems for biomass-derived fuels (biogas), and exploration geophysics for hydrocarbon reservoirs. For wind energy industry HPC is a must. The competitiveness of wind farms can be guaranteed only with accurate wind resource assessment, farm design and short-term micro-scale wind simulations to forecast the daily power production. The use of CFD LES models to analyse atmospheric flow in a wind farm capturing turbine wakes and array effects requires exascale HPC systems. Biogas, i.e. biomass-derived fuels by anaerobic digestion of organic wastes, is attractive because of its wide availability, renewability and reduction of CO₂ emissions, contribution to diversification of energy supply, rural development, and it does not compete with feed and food feedstock. However, its use in practical systems is still limited since the complex fuel composition might lead to unpredictable combustion performance and instabilities in industrial combustors. The next generation of exascale HPC systems will be able to run combustion simulations in parameter regimes relevant to industrial

applications using alternative fuels, which is required to design efficient furnaces, engines, clean burning vehicles and power plants. One of the main HPC consumers is the oil & gas (O&G) industry. The computational requirements arising from full wave-form modelling and inversion of seismic and electromagnetic data is ensuring that the O&G industry will be an early adopter of exascale computing technologies. By taking into account the complete physics of waves in the subsurface, imaging tools are able to reveal information about the Earth's interior with unprecedented quality.

7.3. International Initiatives

7.3.1. Inria Associate Teams not involved in an Inria International Labs

7.3.1.1. HOMAR

Title: High performance Multiscale Algorithms for wave pRopagation problems

International Partner (Institution - Laboratory - Researcher):

Laboratório Nacional de Computação Científica (Brazil) - Coordenação de Matemática Aplicada e Computacional - Frédéric Valentin

Start year: 2015

See also: <http://www-sop.inria.fr/nachos/index.php/Main/HOMAR>

The general scientific context of the collaboration proposed in the HOMAR project is the study of time dependent wave propagation problems presenting multiscale features (in space and time). The general goal is the design, analysis and implementation of a family of innovative high performance numerical methods particularly well suited to the simulation of such multiscale wave propagation problems. Mathematical models based on partial differential equations (PDE) embedding multiscale features occur in a wide range of scientific and technological applications involving wave propagation in heterogeneous media. Electromagnetic wave propagation and seismic wave propagation are two relevant physical settings that will be considered in the project. Indeed, the present collaborative project will focus on two particular application contexts: the interaction of light (i.e. optical wave) with nanometer scale structure (i.e. nanophotonics) and, the interaction of seismic wave propagation with geological media for quantitative and non destructive evaluation of imperfect interfaces.

7.3.2. Inria International Partners

7.3.2.1. Informal International Partners

Prof. Kurt Busch, Humboldt-Universität zu Berlin, Institut für Physik, Theoretical Optics & Photonics

Prof. Martijn Wubs, Technical University of Denmark (DTU), Structured Electromagnetic Materials Theory group

Dr. Urs Aeberhard and Dr. Markus Ermes, Theory and Multiscale Simulation, IEK-5 Photovoltaik, Forschungszentrum Jülich, Germany

7.4. International Research Visitors

7.4.1. Visits of International Scientists

Prof. Liang Li, School of Mathematical Sciences, University of Electronic Science and Technology of China, Chengdu. From March 2016 to February 2017.

Dr. Antonio Tadeu Gomez and Dr. Frédéric Valentin, LNCC, Petropolis, Brazil. From December 15, 2016 to February 15, 2017.

7.4.2. Visits to International Teams

Claire Scheid, guest researcher's stays, KIT, Karlsruhe, financed by the CRC 1173 "Wave phenomena: analysis and numerics": 3 weeks from 12 June to 6 July 2017, and 5 weeks from 19 November to 23 December 2017.

8. Dissemination

8.1. Promoting Scientific Activities

8.1.1. Scientific events organisation

8.1.1.1. General chair, scientific chair

The team has organized the first workshop of the CLIPhTON (advanCed numerical modelIng for multiscale and multiphysics nanoPhoTONics) network that took place at the Inria Sophia Antipolis-Méditerranée research center on November 30-December 1st, 2017.

8.1.2. Invited Talks

Claire Scheid, "Numerical contributions in nanophotonics" Women in PDE's @ Karlsruhe, KIT, Karlsruhe, Germany, April 27-28 2017.

Claire scheid, "A structure preserving numerical discretization framework for the Maxwell Klein Gordon equations in 2D", CRC Seminar, KIT, Karlsruhe, 22 June 2017

Stéphane Lanteri, "Méthodes de type élément fini hybride d'ordre élevé et solveurs par décomposition de domaine pour le calcul de DAS et de SER", Journée Electromagnétisme et Guerre Electronique, Toulouse, France, November 23, 2017.

Stéphane Lanteri, "High order hybridized methods for time-domain and frequency-domain electromagnetics", Congrès Mathias 2017, Paris, France, October 25-27, 2017.

Stéphane Lanteri, "High order DG methods for computational electromagnetics", Barcelona Supercomputing Center, Barcelona, Spain, September 15, 2017.

Stéphane Lanteri, "Discontinuous Galerkin method for computational nanophotonics", Institut Fresnel, Marseille, France, June 9, 2017.

8.1.3. Scientific Expertise

Stéphane Lanteri is a member of the Scientific Committee of CERFACS.

8.1.4. Research Administration

Stéphane Descombes is the head of the Center of Modeling, Simulation and Interactions (MSI) of the UCA JEDI Excellence Initiative. See also: <http://univ-cotedazur.fr/en/uca-innovation/msi/home>.

Stéphane Lanteri is a member of the Project-team Committee's Bureau of the Inria Sophia Antipolis-Méditerranée research center.

Stéphane Lanteri is a member of the Sciences Fondamentales et Appliquées Doctoral School Committee.

8.2. Teaching - Supervision - Juries

8.2.1. Teaching

Stéphane Descombes, *Scientific computing*, M1, 36 h, University Côte d'Azur.

Stéphane Descombes, *Principal components analysis*, M2, 30 h, Université Nice Sophia Antipolis.

Stéphane Lanteri, *High performance scientific computing*, MAM5, 24 h, Polytech Nice Sophia.

Claire Scheid, *Analyse, Lecture and practical works*, Master 2 Agrégation, 27h, University Côte d'Azur.

Claire Scheid, *Analyse Hibernienne et analyse de Fourier; Practical works*, Master 1 MPA, 36h, University Côte d'Azur.

Claire Scheid, *Méthodes numériques en EDP, Lectures and practical works*, Master 1 MPA and IM, 63h, University Côte d'Azur.

Claire Scheid, *Option Modélisation, Lectures and practical works*, Master 2 Agrégation, 48h, University Côte d'Azur.

8.2.2. Supervision

PhD in progress: Alexis Gobé, *Multiscale hybrid-mixed methods for time-domain nanophotonics*, November 2016, Stéphane Lanteri.

PhD in progress: Nikolai Schmitt, *Numerical modeling of electron beam interaction with nanostructures*, October 2015, Stéphane Lanteri and Claire Scheid.

PhD in progress: Georges Nehmetallah, *Efficient finite element type solvers for the numerical modeling of light transmission in nanostructured waveguides and cavities*, November 2017, Stéphane Descombes and Stéphane Lanteri.

9. Bibliography

Major publications by the team in recent years

- [1] M. BENJEMAA, N. GLINSKY-OLIVIER, V. CRUZ-ATIENZA, J. VIRIEUX. *3D dynamic rupture simulations by a finite volume method*, in "Geophys. J. Int.", 2009, vol. 178, pp. 541–560
- [2] S. DELCOURTE, L. FÉZOU, N. GLINSKY-OLIVIER. *A high-order discontinuous Galerkin method for the seismic wave propagation*, in "ESAIM: Proc.", 2009, vol. 27, pp. 70–89
- [3] S. DESCOMBES, C. DUROCHAT, S. LANTERI, L. MOYA, C. SCHEID, J. VIQUERAT. *Recent advances on a DGTD method for time-domain electromagnetics*, in "Photonics and Nanostructures - Fundamentals and Applications", 2013, vol. 11, n^o 4, pp. 291–302
- [4] V. DOLEAN, H. FAHS, F. LOULA, S. LANTERI. *Locally implicit discontinuous Galerkin method for time domain electromagnetics*, in "J. Comput. Phys.", 2010, vol. 229, n^o 2, pp. 512–526
- [5] C. DUROCHAT, S. LANTERI, R. LÉGER. *A non-conforming multi-element DGTD method for the simulation of human exposure to electromagnetic waves*, in "Int. J. Numer. Model., Electron. Netw. Devices Fields", 2013, vol. 27, pp. 614–625
- [6] C. DUROCHAT, S. LANTERI, C. SCHEID. *High order non-conforming multi-element discontinuous Galerkin method for time domain electromagnetics*, in "Appl. Math. Comput.", 2013, vol. 224, pp. 681–704
- [7] M. EL BOUAJAJI, V. DOLEAN, M. GANDER, S. LANTERI. *Optimized Schwarz methods for the time-harmonic Maxwell equations with damping*, in "SIAM J. Sci. Comp.", 2012, vol. 34, n^o 4, pp. A20148–A2071
- [8] M. EL BOUAJAJI, S. LANTERI. *High order discontinuous Galerkin method for the solution of 2D time-harmonic Maxwell's equations*, in "Appl. Math. Comput.", 2013, vol. 219, n^o 13, pp. 7241–7251
- [9] V. ETIENNE, E. CHALJUB, J. VIRIEUX, N. GLINSKY. *An hp-adaptive discontinuous Galerkin finite-element method for 3-D elastic wave modelling*, in "Geophys. J. Int.", 2010, vol. 183, n^o 2, pp. 941–962
- [10] H. FAHS. *Development of a hp-like discontinuous Galerkin time-domain method on non-conforming simplicial meshes for electromagnetic wave propagation*, in "Int. J. Numer. Anal. Mod.", 2009, vol. 6, n^o 2, pp. 193–216

- [11] H. FAHS. *High-order Leap-Frog based biscontinuous Galerkin method for the time-domain Maxwell equations on non-conforming simplicial meshes*, in "Numer. Math. Theor. Meth. Appl.", 2009, vol. 2, n^o 3, pp. 275–300
- [12] H. FAHS, A. HADJEM, S. LANTERI, J. WIART, M. WONG. *Calculation of the SAR induced in head tissues using a high order DGTD method and triangulated geometrical models*, in "IEEE Trans. Ant. Propag.", 2011, vol. 59, n^o 12, pp. 4669–4678
- [13] L. FEZOU, S. LANTERI, S. LOHRENGEL, S. PIPERNO. *Convergence and stability of a discontinuous Galerkin time-domain method for the 3D heterogeneous Maxwell equations on unstructured meshes*, in "ESAIM: Math. Model. Num. Anal.", 2005, vol. 39, n^o 6, pp. 1149–1176
- [14] S. LANTERI, D. PAREDES, C. SCHEID, F. VALENTIN. *The multiscale hybrid-mixed method for the Maxwell equations in heterogeneous media*, 2016, Resubmitted after minor revisions, <https://hal.inria.fr/hal-01393011>
- [15] S. LANTERI, C. SCHEID. *Convergence of a discontinuous Galerkin scheme for the mixed time domain Maxwell's equations in dispersive media*, in "IMA J. Numer. Anal.", 2013, vol. 33, n^o 2, pp. 432–459
- [16] L. LI, S. LANTERI, R. PERRUSSEL. *Numerical investigation of a high order hybridizable discontinuous Galerkin method for 2d time-harmonic Maxwell's equations*, in "COMPEL", 2013, pp. 1112–1138
- [17] L. LI, S. LANTERI, R. PERRUSSEL. *A hybridizable discontinuous Galerkin method combined to a Schwarz algorithm for the solution of 3d time-harmonic Maxwell's equations*, in "J. Comput. Phys.", 2014, vol. 256, pp. 563–581
- [18] R. LÉGER, J. VIQUERAT, C. DUROCHAT, C. SCHEID, S. LANTERI. *A parallel non-conforming multi-element DGTD method for the simulation of electromagnetic wave interaction with metallic nanoparticles*, in "J. Comp. Appl. Math.", 2014, vol. 270, pp. 330–342
- [19] L. MOYA, S. DESCOMBES, S. LANTERI. *Locally implicit time integration strategies in a discontinuous Galerkin method for Maxwell's equations*, in "J. Sci. Comp.", 2013, vol. 56, n^o 1, pp. 190–218
- [20] L. MOYA. *Temporal convergence of a locally implicit discontinuous Galerkin method for Maxwell's equations*, in "ESAIM: Mathematical Modelling and Numerical Analysis", 2012, vol. 46, pp. 1225–1246
- [21] F. PEYRUSSE, N. GLINSKY-OLIVIER, C. GÉLIS, S. LANTERI. *A nodal discontinuous Galerkin method for site effects assessment in viscoelastic media - verification and validation in the Nice basin*, in "Geophys. J. Int.", 2014, vol. 199, n^o 1, pp. 315–334
- [22] J. VIQUERAT, M. KLEMM, S. LANTERI, C. SCHEID. *Theoretical and numerical analysis of local dispersion models coupled to a discontinuous Galerkin time-domain method for Maxwell's equations*, Inria, May 2013, n^o RR-8298, 79 p. , <http://hal.inria.fr/hal-00819758>

Publications of the year

Articles in International Peer-Reviewed Journals

- [23] M. BONNASSE-GAHOT, H. CALANDRA, J. DIAZ, S. LANTERI. *Hybridizable discontinuous Galerkin method for the two-dimensional frequency-domain elastic wave equations*, in "Geophysical Journal International", 2017, n^o 1-38, forthcoming [DOI : 10.1093/GJI/GGX533], <https://hal.inria.fr/hal-01656440>

- [24] A. CHRISTOPHE, S. DESCOMBES, S. LANTERI. *An implicit hybridized discontinuous Galerkin method for the 3D time-domain Maxwell equations*, in "Applied Mathematics and Computation", February 2018, vol. 319, pp. 395 - 408 [DOI : 10.1016/J.AMC.2017.04.023], <https://hal.inria.fr/hal-01674044>
- [25] S. DESCOMBES, S. LANTERI, L. MOYA. *Temporal convergence analysis of a locally implicit discontinuous galerkin time domain method for electromagnetic wave propagation in dispersive media*, in "Journal of Computational and Applied Mathematics", May 2017, n^o 316, pp. 122–132 [DOI : 10.1016/J.CAM.2016.09.038], <https://hal.archives-ouvertes.fr/hal-01244237>
- [26] S. LANTERI, C. SCHEID, J. VIQUERAT. *Analysis of a Generalized Dispersive Model Coupled to a DGTD Method with Application to Nanophotonics*, in "SIAM Journal on Scientific Computing", January 2017, vol. 39, n^o 3, pp. A831 - A859 [DOI : 10.1137/15M105207X], <https://hal.inria.fr/hal-01674031>
- [27] L. LI, T.-Z. HUANG, S. LANTERI, B. LI. *A Reduced-Order Discontinuous Galerkin Method Based on POD for Electromagnetic Simulation*, in "IEEE Transactions on Antennas and Propagation", January 2018, vol. 66, n^o 1, pp. 242 - 254 [DOI : 10.1109/TAP.2017.2768562], <https://hal.inria.fr/hal-01674360>
- [28] L. LI, S. LANTERI, N. A. MORTENSEN, M. WUBS. *A hybridizable discontinuous Galerkin method for solving nonlocal optical response models*, in "Computer Physics Communications", October 2017, vol. 219, pp. 99 - 107 [DOI : 10.1016/J.CPC.2017.05.012], <https://hal.inria.fr/hal-01674506>
- [29] H. WANG, L. LI, B. LI, S. DESCOMBES, S. LANTERI. *A New Family of Exponential-Based High-Order DGTD Methods for Modeling 3-D Transient Multiscale Electromagnetic Problems*, in "IEEE Transactions on Antennas and Propagation", November 2017, vol. 65, n^o 11, pp. 5960 - 5974 [DOI : 10.1109/TAP.2017.2752223], <https://hal.inria.fr/hal-01674026>

International Conferences with Proceedings

- [30] N. SCHMITT, S. LANTERI, C. SCHEID. *3D Simulations of spatially dispersive Metals with a discontinuous Galerkin Time Domain Method*, in "KWT 2017", Riezlern, Austria, September 2017, <https://hal.inria.fr/hal-01675094>
- [31] N. SCHMITT. *3D Simulations of Spatially Dispersive Metals with a Finite Element Time Domain Method*, in "NANOP 2017", Barcelona, Spain, September 2017, <https://hal.inria.fr/hal-01675595>

Conferences without Proceedings

- [32] S. H. CHRISTIANSEN, C. SCHEID. *A structure preserving numerical discretization framework for the Maxwell Klein Gordon equations in 2D*, in "ENUMATH 2017", Voss, Norway, September 2017, <https://hal.archives-ouvertes.fr/hal-01674769>
- [33] S. LANTERI, D. PAREDES, C. SCHEID, F. VALENTIN. *The Multiscale Hybrid Mixed method for time dependent propagation of electromagnetic waves*, in "ENUMATH 2017", Voss, Norway, September 2017, <https://hal.archives-ouvertes.fr/hal-01674774>
- [34] N. SCHMITT, C. SCHEID, J. VIQUERAT, S. LANTERI, A. MOREAU. *A Discontinuous Galerkin Time Domain Method for Plasmonics with a Nonlocal Dispersion Model*, in "PIERS 2017", St. Petersburg, Russia, May 2017, <https://hal.inria.fr/hal-01675601>

- [35] N. SCHMITT, C. SCHEID, J. VIQUERAT, S. LANTERI. *3D Simulations of Spatial Dispersive Metals with a Finite Element Time Domain Method*, in "Plasmonica 2017", Lecce, Italy, July 2017, <https://hal.inria.fr/hal-01675604>

Scientific Books (or Scientific Book chapters)

- [36] S. LANTERI, C. SCHEID, M. KLEMM, J. VIQUERAT. *High order DGTD solver for the numerical modeling of nanoscale light/matter interaction*, in "Spectral and High Order Methods for Partial Differential Equations ICOSAHOM 2016", M. L. BITTENCOURT, N. A. DUMONT, J. S. HESTHAVEN (editors), Lecture Notes in Computational Science and Engineering, Springer, 2017, vol. 119, pp. 243-255, <https://hal.inria.fr/hal-01674472>

Other Publications

- [37] D. CHIRON, C. SCHEID. *Multiple branches of travelling waves for the Gross Pitaevskii equation*, December 2017, working paper or preprint, <https://hal.archives-ouvertes.fr/hal-01525255>
- [38] V. H. NGUYEN, A. DIALLO, P. LE THUC, S. LANTERI, G. F. CARLE. *Antenne miniature implantée pour applications RFID UHF*, May 2017, 20èmes Journées Nationales Microondes (JNM 2017), Poster, <https://hal.archives-ouvertes.fr/hal-01486655>
- [39] V. H. NGUYEN, A. DIALLO, P. LE THUC, R. STARAJ, S. LANTERI, G. F. CARLE. *Identification sans fil de fantômes de petits animaux intégrant un tag RFID UHF implanté miniature*, October 2017, 2 p. , Assemblée générale GDR ONDES "Interférences d'Ondes", Poster, <https://hal.archives-ouvertes.fr/hal-01668669>
- [40] G. PICHON, E. DARVE, M. FAVERGE, S. LANTERI, P. RAMET, J. ROMAN. *Sparse supernodal solver with low-rank compression for solving the frequency-domain Maxwell equations discretized by a high order HDG method*, November 2017, pp. 1-55, Journées jeunes chercheur-e-s - Résolution de problèmes d'ondes harmoniques de grande taille, <https://hal.inria.fr/hal-01660653>
- [41] N. SCHMITT, C. SCHEID, J. VIQUERAT, S. LANTERI. *Simulation of three-dimensional nanoscale light interaction with spatially dispersive metals using a high order curvilinear DGTD method*, November 2017, working paper or preprint, <https://hal.archives-ouvertes.fr/hal-01647074>
- [42] H. WANG, L. XU, B. LI, S. DESCOMBES, S. LANTERI. *A new family of exponential-based high order DGTD methods for modelling 3D transient multiscale electromagnetic problems*, March 2017, working paper or preprint, <https://hal.archives-ouvertes.fr/hal-01523749>

References in notes

- [43] B. COCKBURN, G. KARNIADAKIS, C. SHU (editors). *Discontinuous Galerkin methods. Theory, computation and applications*, Lecture Notes in Computational Science and Engineering, Springer-Verlag, 2000, vol. 11
- [44] B. COCKBURN, C. SHU (editors). *Special issue on discontinuous Galerkin methods*, J. Sci. Comput., Springer, 2005, vol. 22-23
- [45] C. DAWSON (editor). *Special issue on discontinuous Galerkin methods*, Comput. Meth. App. Mech. Engng., Elsevier, 2006, vol. 195
- [46] K. AKI, P. RICHARDS. *Quantitative seismology*, University Science Books, Sausalito, CA, USA, 2002

-
- [47] K. BUSCH, M. KÖNIG, J. NIEGEMANN. *Discontinuous Galerkin methods in nanophotonics*, in "Laser and Photonics Reviews", 2011, vol. 5, pp. 1–37
- [48] B. COCKBURN, J. GOPALAKRISHNAN, R. LAZAROV. *Unified hybridization of discontinuous Galerkin, mixed, and continuous Galerkin methods for second order elliptic problems*, in "SIAM J. Numer. Anal.", 2009, vol. 47, n^o 2, pp. 1319–1365
- [49] A. CSAKI, T. SCHNEIDER, J. WIRTH, N. JAHR, A. STEINBRÜCK, O. STRANIK, F. GARWE, R. MÜLLER, W. FRITZSCHE. *Molecular plasmonics: light meets molecules at the nanosacle*, in "Phil. Trans. R. Soc. A", 2011, vol. 369, pp. 3483–3496
- [50] J. S. HESTHAVEN, T. WARBURTON. *Nodal discontinuous Galerkin methods: algorithms, analysis and applications*, Springer Texts in Applied Mathematics, Springer Verlag, 2007
- [51] J. JACKSON. *Classical Electrodynamics*, Third edition, John Wiley and Sons, INC, 1998
- [52] X. JI, W. CAI, P. ZHANG. *High-order DGTD method for dispersive Maxwell's equations and modelling of silver nanowire coupling*, in "Int. J. Numer. Meth. Engng.", 2007, vol. 69, pp. 308–325
- [53] J. NIEGEMANN, M. KÖNIG, K. STANNIGEL, K. BUSCH. *Higher-order time-domain methods for the analysis of nano-photonic systems*, in "Photonics Nanostruct.", 2009, vol. 7, pp. 2–11
- [54] A. TAFLOVE, S. HAGNESS. *Computational electrodynamics: the finite-difference time-domain method (3rd edition)*, Artech House, 2005
- [55] J. VIRIEUX. *P-SV wave propagation in heterogeneous media: velocity-stress finite difference method*, in "Geophysics", 1986, vol. 51, pp. 889–901
- [56] K. YEE. *Numerical solution of initial boundary value problems involving Maxwell's equations in isotropic media*, in "IEEE Trans. Antennas and Propagation", 1966, vol. 14, n^o 3, pp. 302–307
- [57] Y. ZHENG, B. KIRALY, P. WEISS, T. HUANG. *Molecular plasmonics for biology and nanomedicine*, in "Nanomedicine", 2012, vol. 7, n^o 5, pp. 751–770